

BJ4 WORLDS EDITION SET-UP SHEET:

DRIVER _____

DATE _____

TRACK/CITY _____

EVENT _____

NOTES:



TRACK CONDITIONS:

SOFT SURFACES:	HARD SURFACES:
SAND / SOIL _____	WET _____
LOAMY _____	HARD SLICK _____
RUTS _____	ABRASIVE _____
WET _____	BLUE GROOVE _____
DRY _____	BLACK GROOVE _____
	BROKEN _____

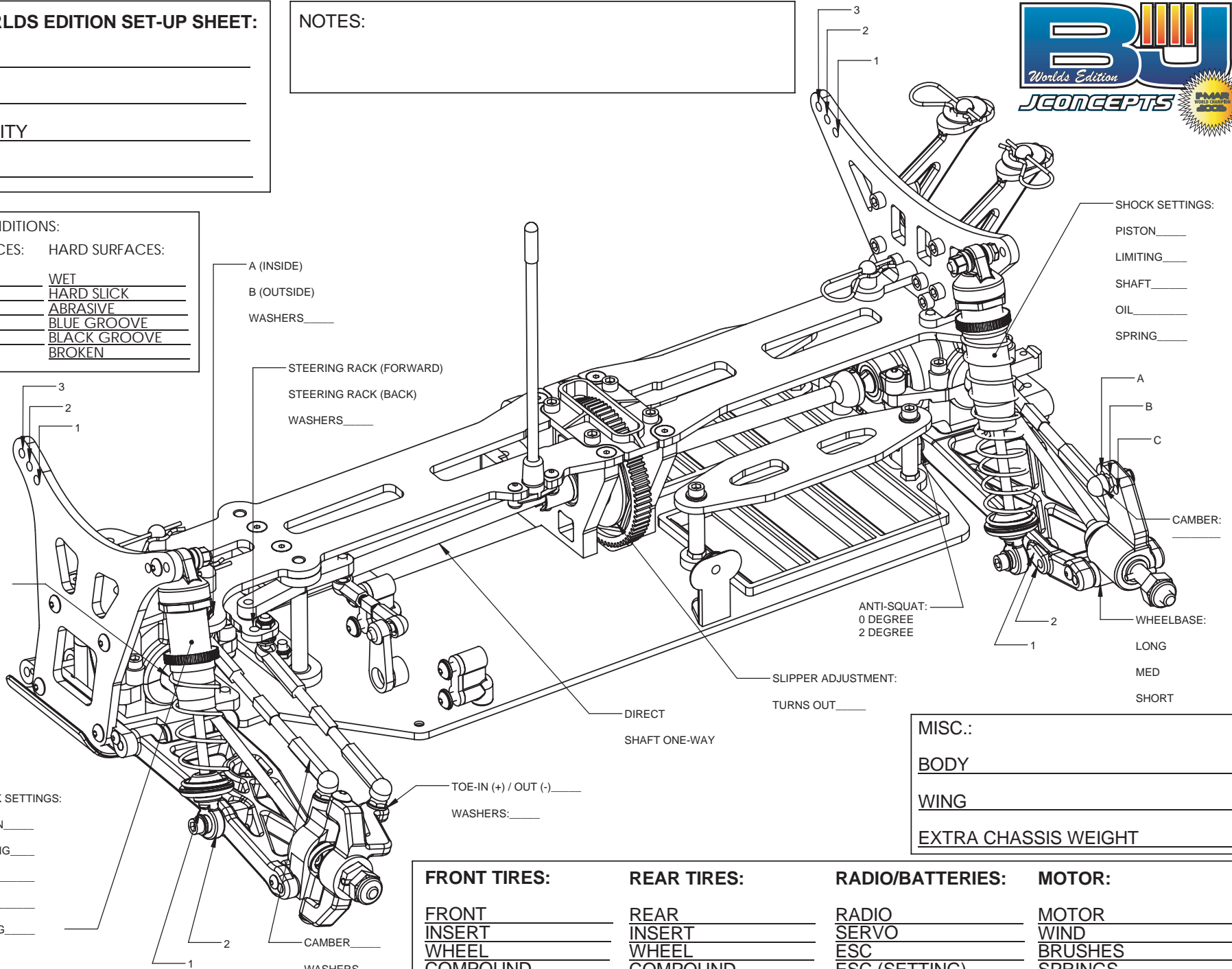

SHOCK SETTINGS:
 PISTON _____
 LIMITING _____
 SHAFT _____
 OIL _____
 SPRING _____

CAMBER:

 WHEELBASE:
 LONG
 MED
 SHORT

ANTI-SQUAT:
 0 DEGREE
 2 DEGREE

SLIPPER ADJUSTMENT:
 TURNS OUT _____

DIRECT
 SHAFT ONE-WAY

TOE-IN (+) / OUT (-) _____
 WASHERS: _____

MISC.:
 BODY _____
 WING _____
 EXTRA CHASSIS WEIGHT _____

SHOCK SETTINGS:
 PISTON _____
 LIMITING _____
 SHAFT _____
 OIL _____
 SPRING _____

FRONT TIRES:	REAR TIRES:	RADIO/BATTERIES:	MOTOR:
FRONT _____	REAR _____	RADIO _____	MOTOR _____
INSERT _____	INSERT _____	SERVO _____	WIND _____
WHEEL _____	WHEEL _____	ESC _____	BRUSHES _____
COMPOUND _____	COMPOUND _____	ESC (SETTING) _____	SPRINGS _____
ADDITIVE _____	ADDITIVE _____	BATTERIES _____	PINON/SPUR _____

A (INSIDE)
 B (OUTSIDE)
 WASHERS _____

STEERING RACK (FORWARD)
 STEERING RACK (BACK)
 WASHERS _____

ONE-WAY
 DIFF

3
 2
 1

2
 1
 CAMBER _____
 WASHERS _____