

Driver **Lee Chorley**

Date **22/07/18**

Track **Bury**

Event **Club Championship**

Track Condition **Dry Astro**

Temperature **22**

FRONT

FRONT KICK-UP



Front/Front	Front/Rear	Kick-up
•	•	10°
••	•	9°
•••	•	8°
•	••	11°
••	••	10°
•••	••	9°
•	•••	12°
••	•••	11°
•••	•••	10°

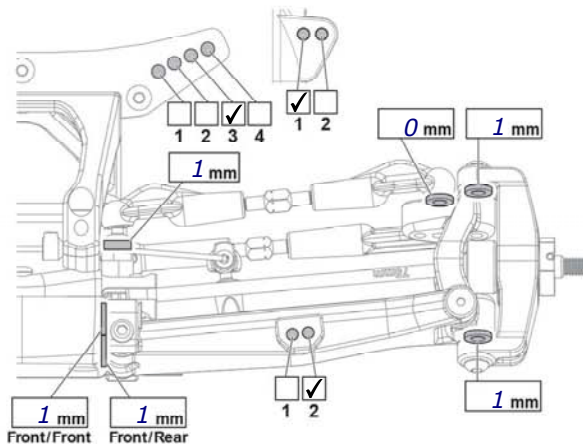

FRONT SHOCKS

Oil wt.	700
Piston	1.6
Bladder	Yes
Spring	Sworz Blue
Notes	AE spring collar

Ride Height	17 mm
Droop	mm
Camber Angle	-1°
Toe Angle	0°
Sway Bar	1.4 mm
Shock Length	75 mm



REAR

REAR ANTI-SQUAT



Rear/Front	Rear/Rear	Anti-squat
•	•	0°
•	••	1°
•	•••	2°
••	••	0°
••	•••	1°
•••	•••	0°
•••	••	-1°

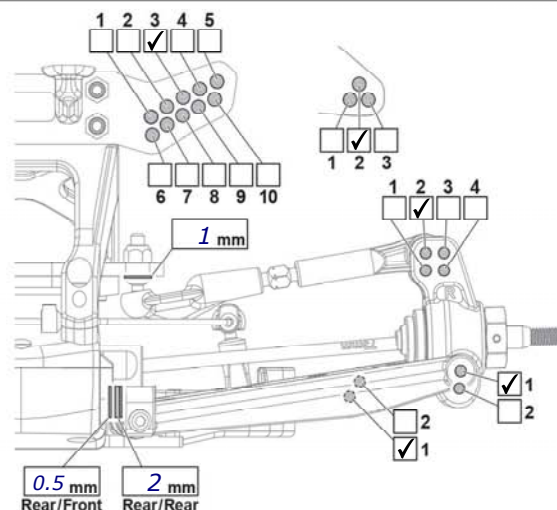

REAR SHOCKS

Oil wt.	500
Piston	1.7
Bladder	Yes
Spring	35
Notes	

Ride Height	17 mm
Droop	mm
Camber Angle	-2°
Toe Angle	3.5°
Sway Bar	Copper mm
Shock Length	90 mm



TIRES

Tire	Front stagger	Rear dart
Insert	molded	med

Battery	
Motor	6.5
Gearing	25 / 72
Body / Wing	/

DIFF OIL

	Front	Center	Rear
Brand	xtr	core	xtr
Oil wt.	15000	300000	10000

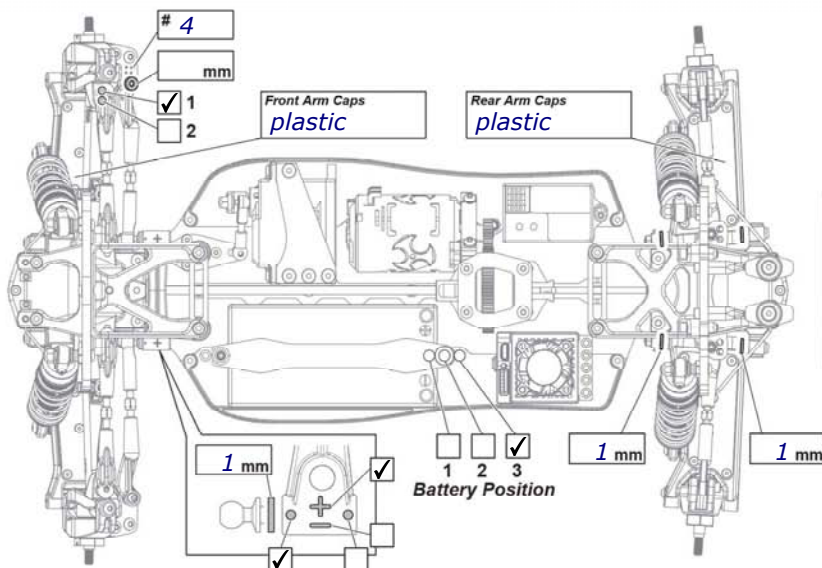

REAR TOE-IN

R/F	R/R	Toe-in
0.5mm	0.5mm	2.0°
0.5mm	1.0mm	2.5°
0.5mm	1.5mm	3.0°
0.5mm	2.0mm	3.5°

Notes:

Gear Ratio = $\frac{\text{Spur Gear}}{\text{Pinion Gear}} \times 3.3077$