

Name Ty Tessmann

Date March 2016

Event Chitown Shootout

Track Leisure Hours

Track Condition Bumpy, med bite

## Front

### Front kick-up



F/F	F/R	Kick-UP	
•	•	10°	
••	•	9°	✓
•••	•	8°	
•	••	11°	
••	••	10°	
•••	••	9°	
•	•••	12°	
••	•••	11°	
•••	•••	10°	

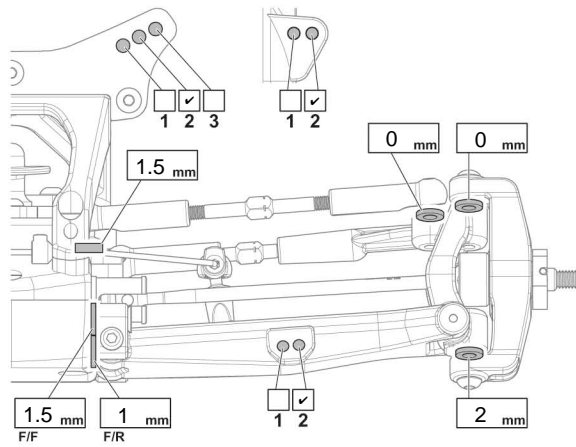

Arm Plates carbon

Ride Height	21	mm
Camber Angle	1	°
Toe Angle	.5 out	°
Sway Bar	copper	

### Shocks

Oil wt.	35/37.5
Piston	2 x 1.6
Spring	HB Gold
*Shock Length	22.5 mm

Notes bellows bladder

no screw

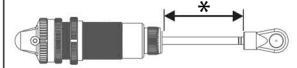

## Rear

### Rear anti-squat



R/F	R/R	Anti-squat	
•	•	0°	
•	••	1°	
•	•••	2°	
••	••	0°	
••	•••	1°	✓
•••	•••	0°	

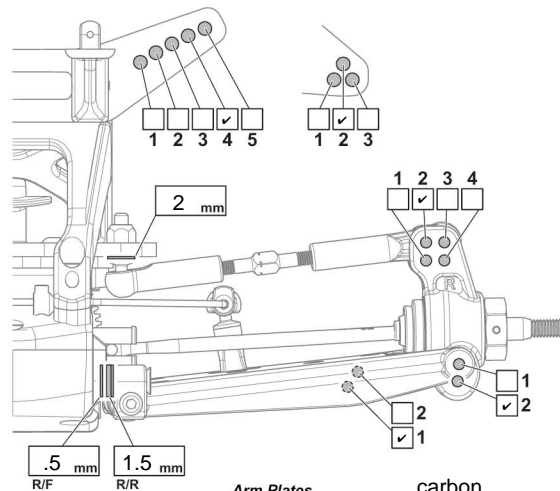

Arm Plates carbon

Ride Height	21	mm
Camber Angle	1	°
Toe Angle	3 deg	°
Sway Bar	copper	

### Shocks

Oil wt.	30/32.5
Piston	2 x 1.7
Spring	HB Yellow
*Shock Length	29.5 mm

Notes

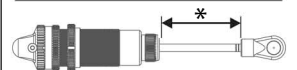

## Tires

Front

Rear

Tire

Insert

Battery  Shorty /  Saddle

Position Front / Mid / Back

Motor Orion 5.5

Gearing /

Body / Wing Typer R / HB

### Diff Oils

Front

Center

Rear

Brand

Losi

Losi

Oil wt.

10K

5K

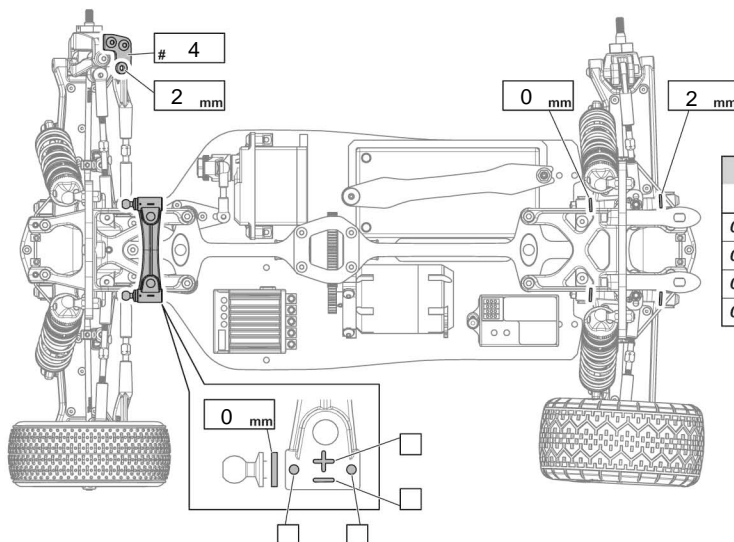

### Rear toe-in

R/F	R/R	Toe-in	
0.5mm	0.5mm	2.0°	
0.5mm	1.0mm	2.5°	
0.5mm	1.5mm	3.0°	✓
0.5mm	2.0mm	3.5°	

### Wing Height:

High

Medium

Low

Notes Slipper in center, orion xs 3800 battery, aluminum steering rack, avid chassis