

Name _____ Date _____ Event _____ Track _____
 Track Condition _____

Front

Front kick-up		
F/F	F/R	Kick-UP
•	•	10°
••	•	9°
•••	•	8°
•	••	11°
••	••	10°
•••	••	9°
•	•••	12°
••	•••	11°
•••	•••	10°

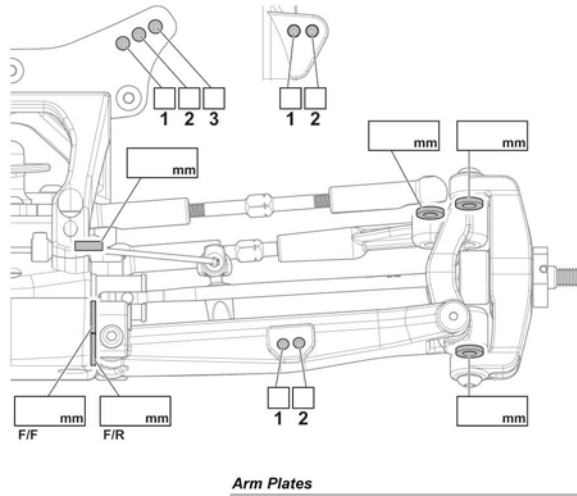

Ride Height _____ mm
 Camber Angle _____ °
 Toe Angle _____ °
 Sway Bar _____

Shocks	
Oil wt.	_____
Piston	_____
Spring	_____
*Shock Length	_____ mm
Notes	_____

Rear

Rear anti-squat		
R/F	R/R	Anti-squat
•	•	0°
•	••	1°
•	•••	2°
••	••	0°
••	•••	1°
•••	•••	0°

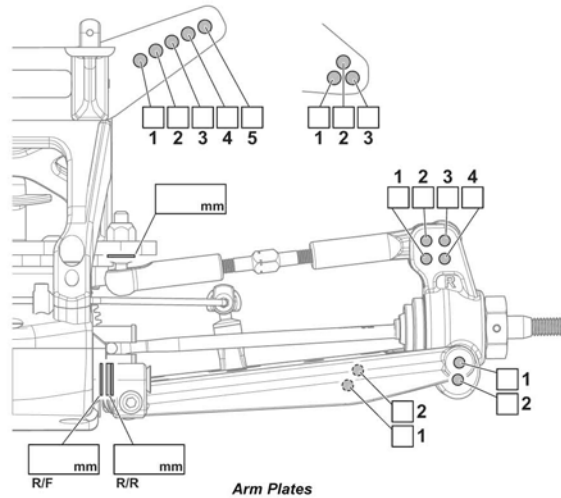

Ride Height _____ mm
 Camber Angle _____ °
 Toe Angle _____ °
 Sway Bar _____

Shocks	
Oil wt.	_____
Piston	_____
Spring	_____
*Shock Length	_____ mm
Notes	_____

Tires

	Front	Rear
Tire	_____	_____
Insert	_____	_____

Battery _____ Shorty / Saddle _____
 Position _____ Front / Mid / Back _____
 Motor _____
 Gearing _____ / _____
 Body / Wing _____ / _____

Diff Oils

	Front	Center	Rear
Brand	_____	_____	_____
Oil wt.	_____	_____	_____

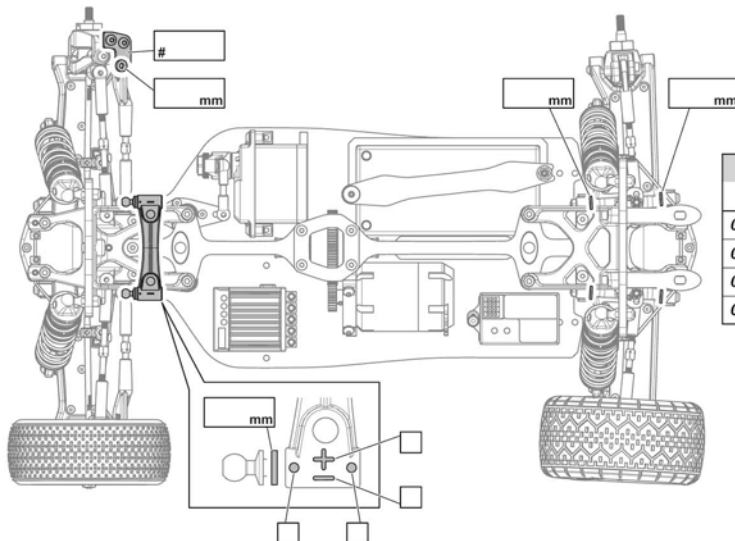

Rear toe-in		
R/F	R/R	Toe-in
0.5mm	0.5mm	2.0°
0.5mm	1.0mm	2.5°
0.5mm	1.5mm	3.0°
0.5mm	2.0mm	3.5°

Wing Height:
 High
 Medium
 Low

Notes _____