

Name **David Ronnefalk**

Date **9-11 Jan 2015** Event **DHI-Cup**

Track **Odense, Denmark**

Track Condition **Carpet - high bite**

Front

Front kick-up		
F/F	F/R	Kick-UP
•	•	10°
••	•	9°
•••	•	8°
•	••	11°
••	••	10°
•••	••	9°
•	•••	12°
••	•••	11°
•••	•••	10°

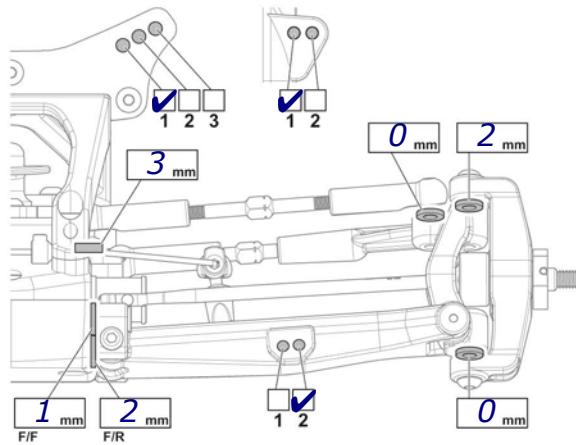

Arm Plates **Plastic**

Ride Height **17 mm**
 Camber Angle **1°**
 Toe Angle **+5°**
 Sway Bar **1.8**

Shocks
 Oil wt. **70**
 Piston **2x1.6**
 Spring **Red**
 *Shock Length **22 mm**
 Notes **3mm limiter**

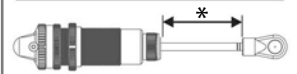

Rear

Rear anti-squat		
R/F	R/R	Anti-squat
•	•	0°
•	••	1°
•	•••	2°
••	••	0°
••	•••	1°
•••	•••	0°

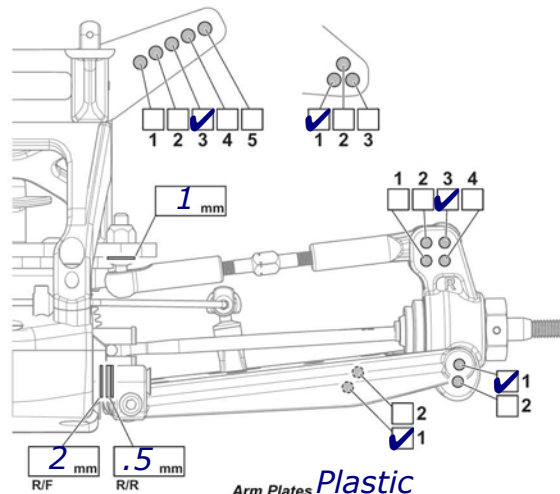

Arm Plates **Plastic**

Ride Height **18 mm**
 Camber Angle **2°**
 Toe Angle **3.5°**
 Sway Bar **1.8**

Shocks
 Oil wt. **35**
 Piston **3x1.4**
 Spring **Red**
 *Shock Length **30.5 mm**
 Notes **2mm limiter**

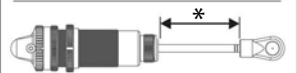

Tires

	Front	Rear
Tire	Mini Pin	Mini Pin
Insert	Schumacher Medium	Schumacher Medium

Battery Sporty / Saddle
 Position Front / Mid / Back
 Motor **5.5 Orion VST2**
 Gearing **21** / **Std**
 Body / Wing **Type-R / LMR Avior**

Diff Oils

	Front	Center	Rear
Brand	Kyo	Kyo	Kyo
Oil wt.	10k	60k	10k

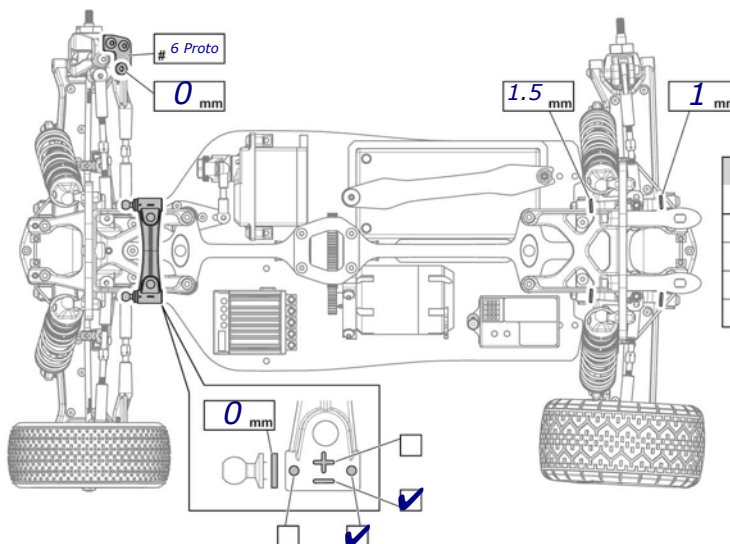

Rear toe-in		
R/F	R/R	Toe-in
0.5mm	0.5mm	2.0°
0.5mm	1.0mm	2.5°
0.5mm	1.5mm	3.0°
0.5mm	2.0mm	3.5°

Wing Height:
 High
 Medium
 Low

Notes