

Name **David Ronnefalk**

Date **23/11-14**

Event **Practice**

Track **Klippan**

Track Condition **Carpet - medium bite**

Front

Front kick-up



F/F	F/R	Kick-UP	
.	.	10°	
..	.	9°	
...	.	8°	<input checked="" type="checkbox"/>
.	..	11°	
..	..	10°	
...	..	9°	
.	...	12°	
..	...	11°	
...	...	10°	

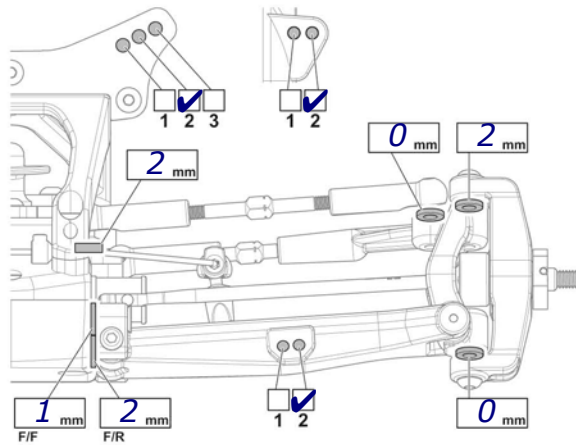

Arm Plates **Carbon**

Ride Height **15 mm**
 Camber Angle **1°**
 Toe Angle **+5°**
 Sway Bar **1.6 Kyo**

Shocks

Oil wt. **50**
 Piston **2x1.6**
 Spring **Red**
 *Shock Length **23.9 mm**

Notes **No Limiter**

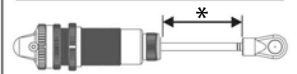

Rear

Rear anti-squat



R/F	R/R	Anti-squat	
.	.	0°	
.	..	1°	
.	...	2°	<input checked="" type="checkbox"/>
..	..	0°	
..	...	1°	
...	...	0°	

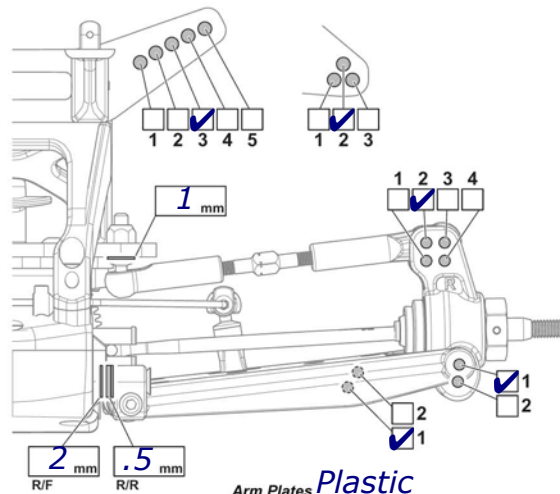

Arm Plates **Plastic**

Ride Height **16 mm**
 Camber Angle **2°**
 Toe Angle **3.5°**
 Sway Bar **1.6 Kyo**

Shocks

Oil wt. **35**
 Piston **3x1.4**
 Spring **Red**
 *Shock Length **32.5 mm**

Notes **No Limiter**

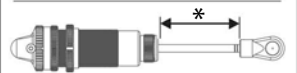

Tires

Front

Rear

Tire	VBC Slick	VBC Slick
Insert	VBC	VBC

Battery Sporty / Saddle

Position Front / Mid / Back

Motor **5.5 Orion VST2**

Gearing **21** / Std

Body / Wing **Type-R** / LMR Avior

Diff Oils

Front

Center

Rear

Brand	Kyo	Kyo	Kyo
Oil wt.	20k	60k	10k

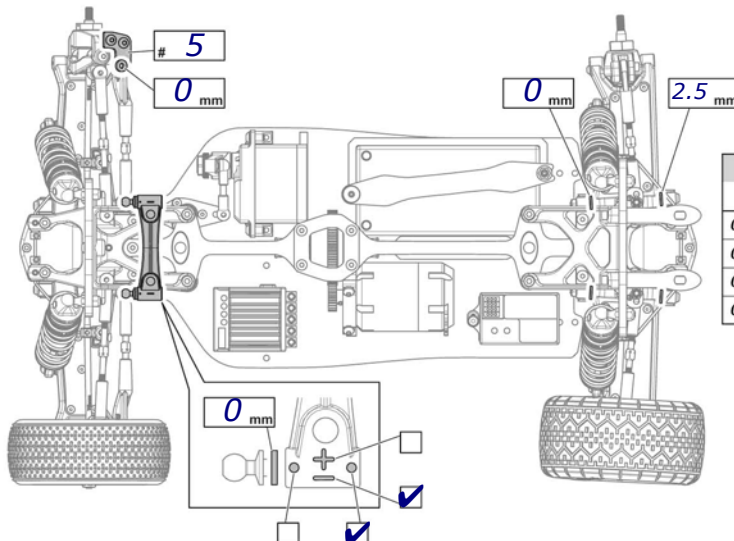

Rear toe-in		
R/F	R/R	Toe-in
0.5mm	0.5mm	2.0°
0.5mm	1.0mm	2.5°
0.5mm	1.5mm	3.0°
0.5mm	2.0mm	3.5°

Wing Height:

- High
 Medium
 Low

Notes **Avid Chassi with 7g inserts bothe front and rear.**