

Name _____ Date _____ Event _____ Track _____

Track Condition: Indoor Outdoor _____ Temperature _____
 Astroturf Carpet Clay Dirt Grass _____
 Blue Groove Dusty Hard Packed Loose Loamy _____
 Low Medium High Bumpy Smooth _____

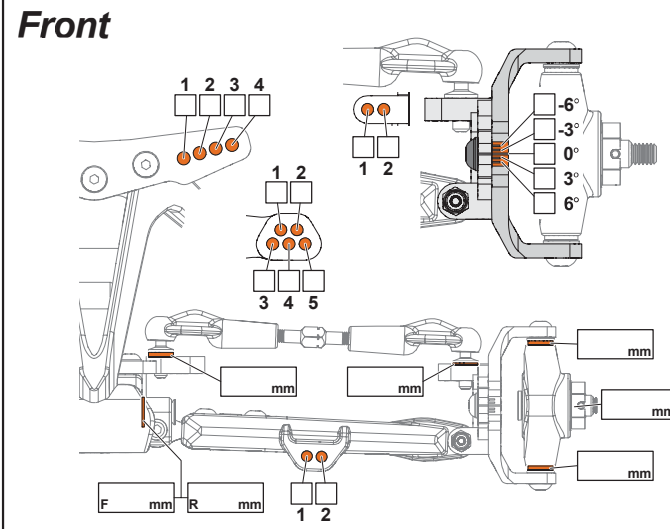

Ride Height _____ mm

Camber Angle _____ °

Toe Angle _____ °

Front
 Center
 Back

Notes _____

Kick-up

F/F	F/R	
•	•	22.5°
••	•	21.2°
•••	•	20.0°
•	••	23.8°
••	••	22.5°
•••	••	21.2°
•	•••	25.0°
••	•••	23.8°
•••	•••	22.5°

Shocks

Oil _____

Piston _____

Hole Diameter _____ mm

Nbr of holes: 1 2 3

Spring _____

Shock Length _____ mm

Notes _____

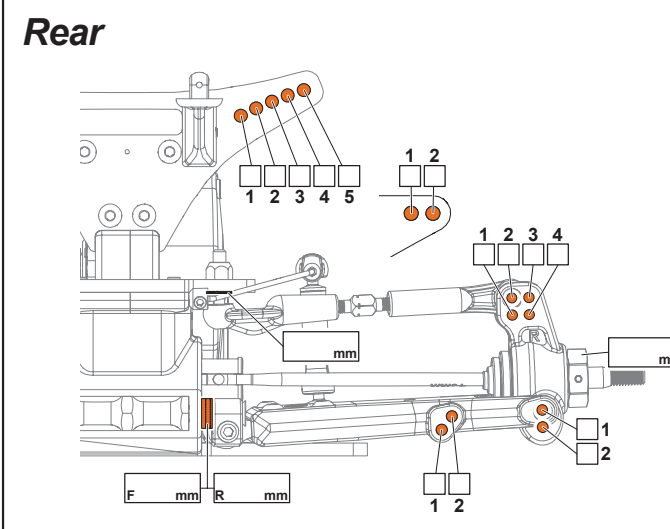

Ride Height _____ mm

Camber Angle _____ °

Toe Angle _____ °

Sway Bar _____

Notes _____

Anti-Squat

R/F	R/R	
•	•	1.5°
••	•	0.5°
•••	•	-0.5°
•	••	3.0°
••	••	1.5°
•••	••	0.5°
•	•••	4.0°
••	•••	3.0°
•••	•••	1.5°

Shocks

Oil _____

Piston _____

Hole Diameter _____ mm

Nbr of holes: 1 2 3

Spring _____

Shock Length _____ mm

Notes _____

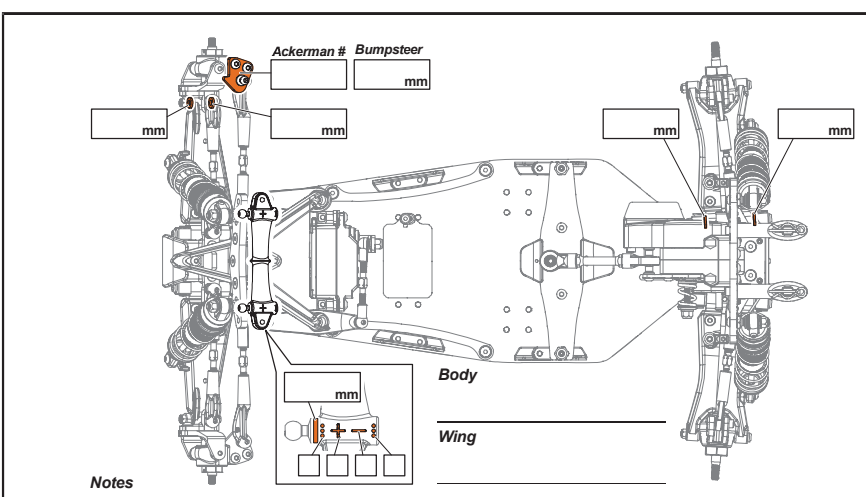

Battery Position

Inline Sideway

Rear Toe-in

R/F	R/R	Toe-in
0.5mm	1.5mm	1.5°
0.5mm	2.0mm	2.0°
0.5mm	2.5mm	2.5°
0.5mm	3.0mm	3.0°

Differential

Gear Oil _____

Ball

Servo

Front Rear

Wing Height

Low Mid High

Battery _____ Pinion _____

Motor _____ Spur _____

ESC _____ Servo _____ Receiver _____

Front Tires

Tire _____

Insert _____ Wheel _____

Notes _____

Rear Tires

Tire _____

Insert _____ Wheel _____

Notes _____