

Driver _____ **Date** _____ **Track** _____ **Event** _____
 Composition: AstroTurf Clay Carpet Dirt Grass Wood Traction: Low Medium High Dry
Track Condition Other: _____ Surface: Bumpy Smooth Wet

Front

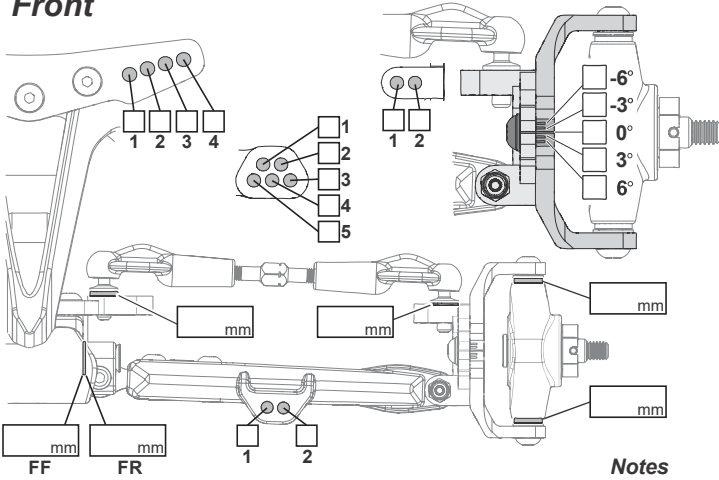

Ride Height _____ mm
Camber Angle _____ °
Toe Angle _____ °
 Front Center Back

Front Kick-Up		
F/F	F/R	Kick-Up
•	•	22.5°
••	•	21.2°
•••	•	20.0°
•	••	23.8°
••	••	22.5°
•••	••	21.2°
•	•••	25.0°
••	•••	23.8°
•••	•••	22.5°

Front Shocks	
Oil Weight	_____ wt
Piston	_____
Spring	_____
*Shock Length	_____ mm
Notes	_____



Notes _____

Rear

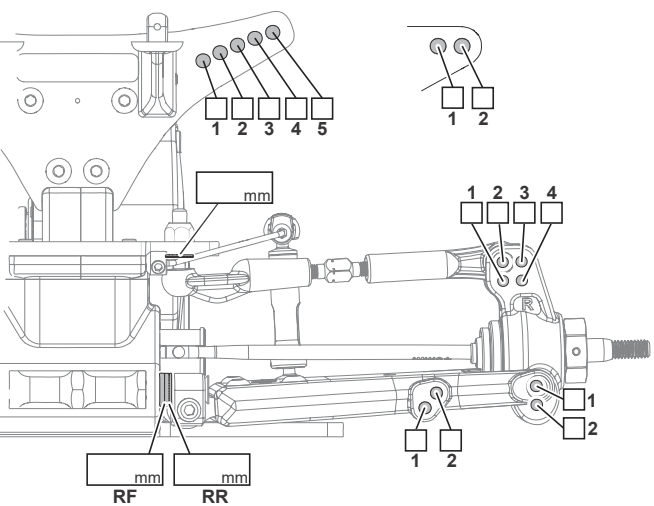

Ride Height _____ mm
Camber Angle _____ °
Toe Angle _____ °
Sway Bar _____

Rear Anti-Squat		
R/F	R/R	Anti-Squat
•	•	1.5°
••	•	0.5°
•••	•	-0.5°
•	••	3.0°
••	••	1.5°
•••	••	0.5°
•	•••	4.0°
••	•••	3.0°
•••	•••	1.5°

Rear Shocks	
Oil Weight	_____ wt
Piston	_____
Spring	_____
*Shock Length	_____ mm
Notes	_____



Notes _____

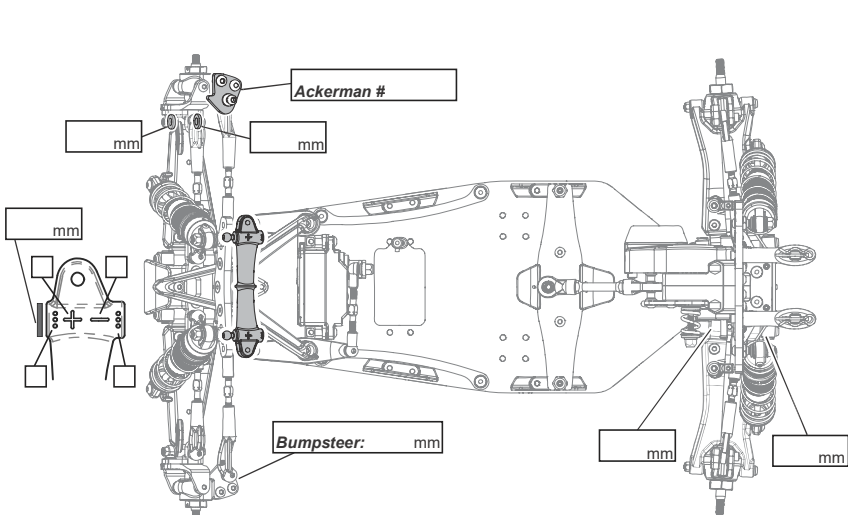

Rear Toe-in		
R/F	R/R	Toe-in
0.5mm	1.5mm	1.5°
0.5mm	2.0mm	2.0°
0.5mm	2.5mm	2.5°
0.5mm	3.0mm	3.0°

Differential
 Gear Oil Wt. _____
 Ball

Servo
 Front Rear

Wing Height
 Low Mid High

Tires	Front	Rear
Tire	_____	_____
Insert	_____	_____
Notes	_____	_____

Battery _____
 Motor _____
 Pinion _____ Spur _____
 Body/Wing _____

Battery Position
 Inline • ••
 Sideways •• •••

Notes _____