

## SETUP SHEET

**Name:** \_\_\_\_\_ **Date:** \_\_\_\_\_  
**Event:** \_\_\_\_\_ **Track:** \_\_\_\_\_

### Track Conditions

- |                                     |                                       |  |                                |
|-------------------------------------|---------------------------------------|--|--------------------------------|
| <input type="checkbox"/> Smooth     | <input type="checkbox"/> Hard Packed  | <input type="checkbox"/> Blue Groove   | <input type="checkbox"/> Wet   |
| <input type="checkbox"/> Rough      | <input type="checkbox"/> Loose        | <input type="checkbox"/> Dry           | <input type="checkbox"/> Dusty |
| <input type="checkbox"/> Grass      | <input type="checkbox"/> Low Traction | <input type="checkbox"/> High Traction | Temp _____ °C/°F               |
| <input type="checkbox"/> Astro Turf | <input type="checkbox"/> Med Traction | <input type="checkbox"/> Other _____   |                                |

### Front Suspension

Toe: \_\_\_\_\_  
 Ride Height: \_\_\_\_\_  
 Camber: \_\_\_\_\_  
 Caster:  30°  35°  
 Kick Angle:  20°  25°  
 Shock Oil: \_\_\_\_\_  
 Piston: \_\_\_\_\_  
 Spring: \_\_\_\_\_  
 Bump Steer Spacer: \_\_\_\_\_

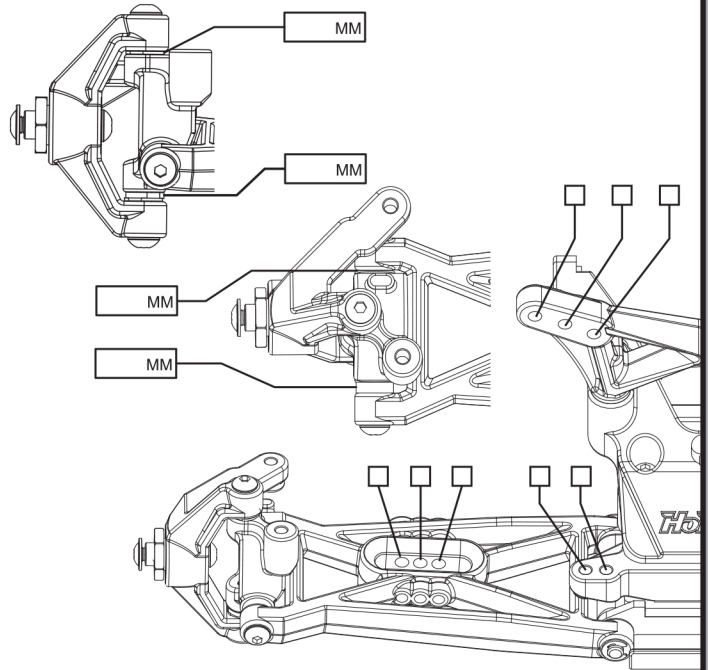

### Rear Suspension

Chassis Configuration:  Rear Motor  Mid Motor  
 Toe: \_\_\_\_\_  
 Anti-Squat:  1°  2°  3°  
 Ride Height: \_\_\_\_\_  
 Camber: \_\_\_\_\_  
 Wheelbase: \_\_\_\_\_  
 Sway Bar: \_\_\_\_\_  
 Shock Oil: \_\_\_\_\_  
 Piston: \_\_\_\_\_  
 Spring: \_\_\_\_\_  
 Differential:  Ball  Gear Fluid: \_\_\_\_\_  
 Battery Position: \_\_\_\_\_

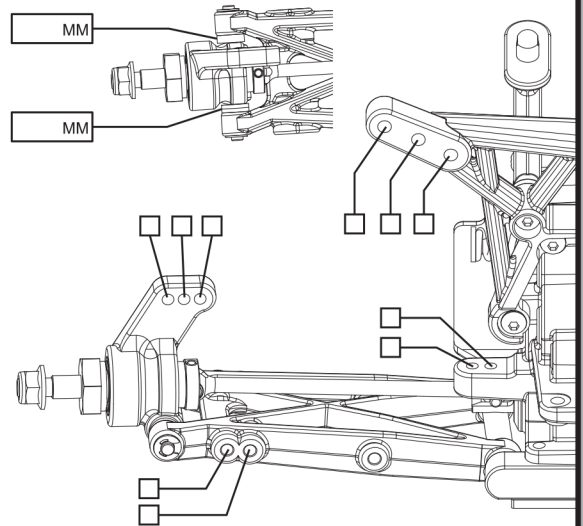

### Front Tires

Tire: \_\_\_\_\_  
 Compound: \_\_\_\_\_  
 Insert: \_\_\_\_\_  
 Wheel: \_\_\_\_\_

### Rear Tires

Tire: \_\_\_\_\_  
 Compound: \_\_\_\_\_  
 Insert: \_\_\_\_\_  
 Wheel: \_\_\_\_\_

### Electronics

Radio: \_\_\_\_\_ Timing Advance: \_\_\_\_\_  
 Servo: \_\_\_\_\_ Throttle/Brake Expo: \_\_\_\_\_  
 ESC: \_\_\_\_\_ Servo Expo: \_\_\_\_\_  
 Initial Brake: \_\_\_\_\_ Throttle/Brake EPA: \_\_\_\_\_  
 Drag Brake: \_\_\_\_\_ Motor: \_\_\_\_\_  
 Throttle Profile: \_\_\_\_\_ Pinion: \_\_\_\_\_ Spur: \_\_\_\_\_  
 Battery: \_\_\_\_\_

### Notes

\_\_\_\_\_  
 \_\_\_\_\_  
 \_\_\_\_\_  
 \_\_\_\_\_