

# TEAM DURANGO DEX410

# SETUP SHEET

セットアップシート V2.1J

DRIVER

DATE

EVENT

TRACK

AIR TEMP

TRACK SIZE

SURFACE

TRACTION LEVEL

CONDITIONS

RIDE HEIGHT

CAMBER ANGLE

CASTOR ANGLE

TOE IN/OUT

DIFF. OIL

SWAY BAR

SWAY BAR LINK

NOTES

## FRONT フロント

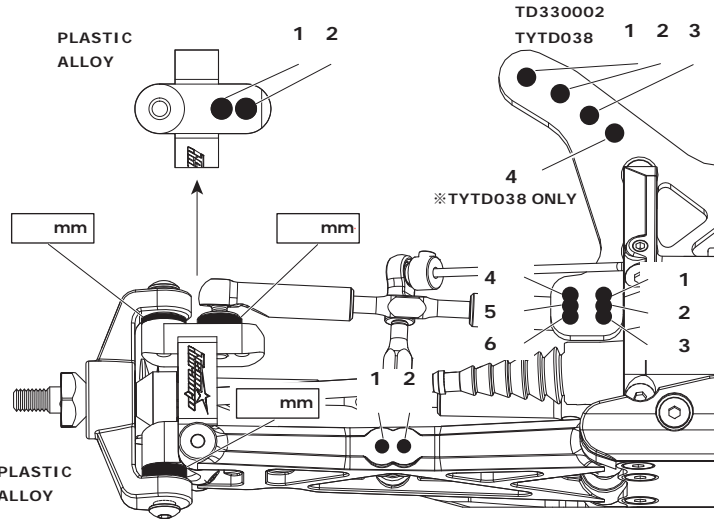

## FRONT SHOCKS フロント ショック

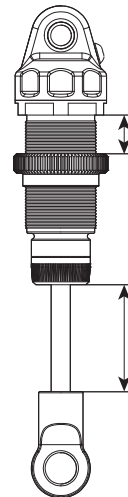

- NORMAL
- MOS COAT
- BIG BORE
- SPRINGS
- REBOUND
- PRELOAD
- OIL WT.
- PISTON
- LENGTH
- NOTES

RIDE HEIGHT

CAMBER ANGLE

DIFF. OIL

SWAY BAR

SWAY BAR LINK

WISHBONE DROOP

NOTES

## REAR リア

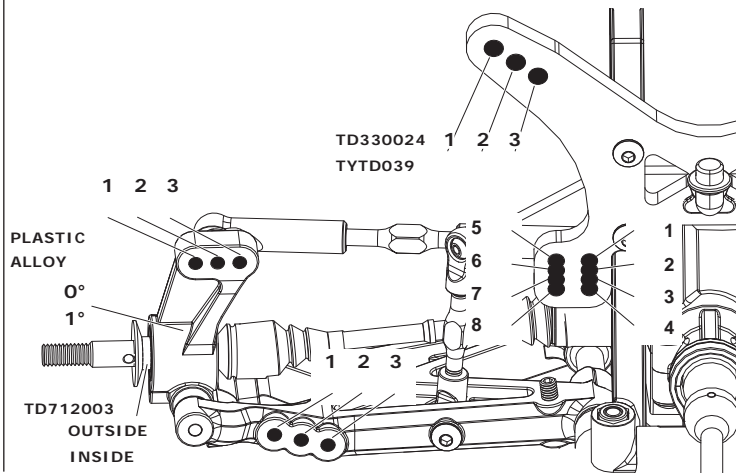

## REAR SHOCKS HINTEN DÄMPFER ARRIÈRE AMORTISSEURS リアショック

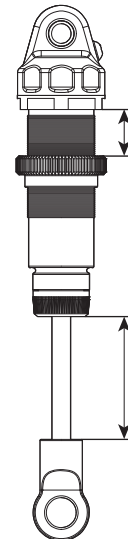

- NORMAL
- MOS COAT
- BIG BORE
- SPRINGS
- REBOUND
- PRELOAD
- OIL WT.
- PISTON
- LENGTH
- NOTES

MOTOR

SPUR GEAR

PINION GEAR

BATTERY

ESC SETTINGS

BALLAST POSITION

SIDES

SKIDPLATE

HIGH TRACTION

WING

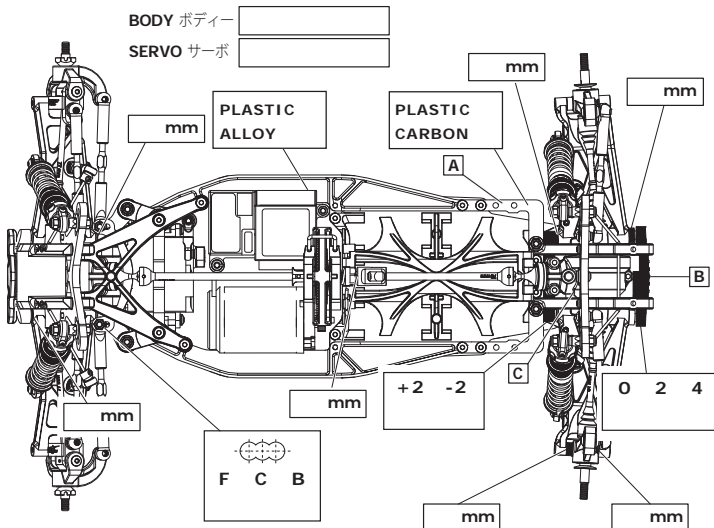

## TYRES タイヤ

	FRONT	REAR
BRAND	<input type="text"/>	<input type="text"/>
TREAD/COMPOUND	<input type="text"/>	<input type="text"/>
INSERT	<input type="text"/>	<input type="text"/>
WHEEL	<input type="text"/>	<input type="text"/>
NOTES	<input type="text"/>	

## RESULTS

AVG. LAP

QUALIFYING POSITION

BEST LAP

FINAL POSITION

RACE TIME

