

TEAM DURANGO DEX410 SETUP SHEET

PRINT

SUBMIT

NAME / NOM: Benni 'G-Spot' Groschel

DATE / DATUM: 30/08/2009

SETUP BLATT / FICHE DE RÉGLAGE V1.2 E

EVENT / VERANSTALTUNG: German National Championships 2009

TRACK / STRECKE: Leipzig

AIR TEMP / UMGEBUNGSTEMP.: 25 °C

TRACK SIZE / STRECKENGRÖSSE: Large

SURFACE / STRECKENBELAG: Soft Dirt

TRACTION LEVEL / GRIFF: High

CONDITIONS / WETTER: Dry

FRONT VORN AVANT

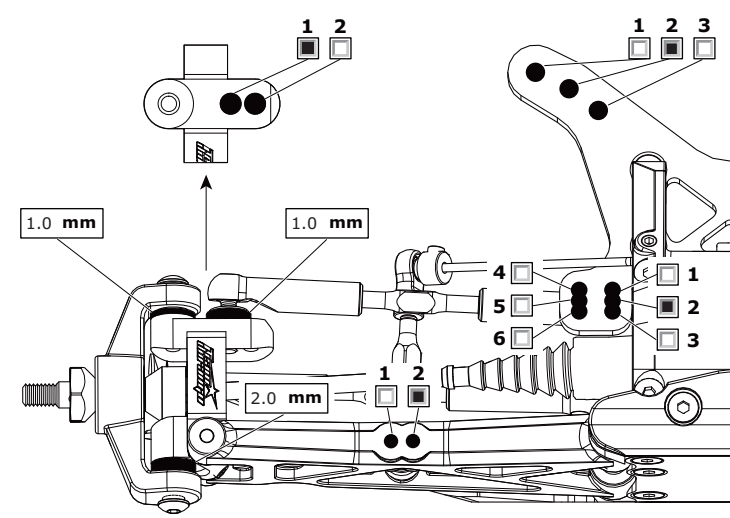

REAR HINTEN ARRIÈRE

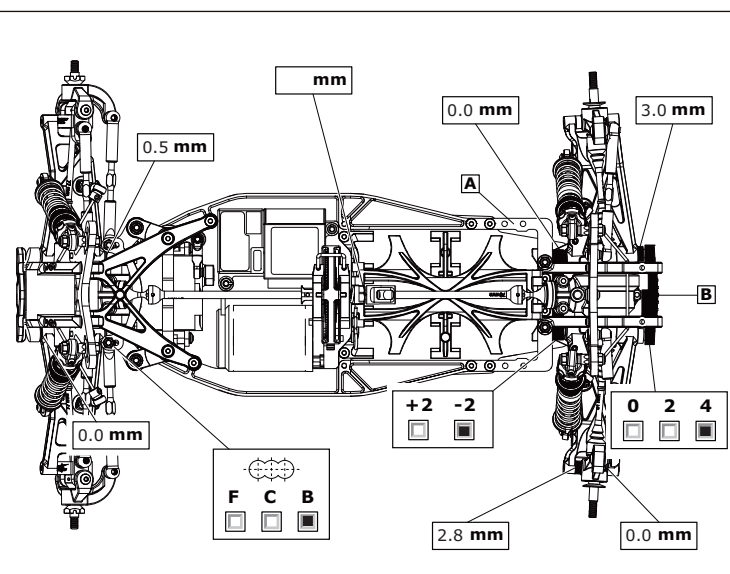
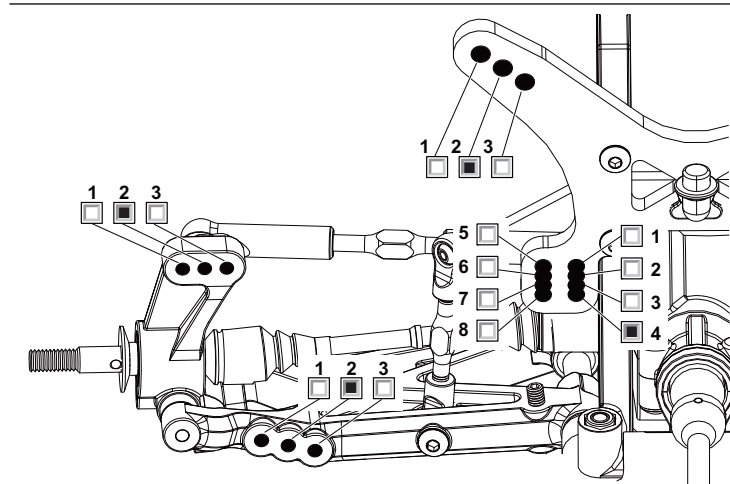

RIDE HEIGHT / **BODENFREIHEIT** / **RESSORTS**
Dogbones Level mm

CAMBER ANGLE / **STURZ** / **ANGLE DE CORROSSAGE**
-1 °

CASTOR ANGLE / **NACHLAUF** / **ANGLE DE CHASSE**
Kit °

TOE IN/OUT / **VONSPUR/NACHSPUR** / **ANGLE DE PINCEMENT**
+/- 0 mm

DIFF. OIL / **DIFF. ÖL** / **HUILE DE DIFF.**
20,000 .wt

SWAY BAR / **STABILISATOR** / **BARRE ANTI-ROULI**
None mm

SWAY BAR LINK / **STABILISATOR HEBELLANGE** / **LIEN DE LA BARRE ANTI-ROULI**
N/A mm

NOTES / **NOTIZEN** / **NOTES**
LRP Diff Oil

RIDE HEIGHT / **BODENFREIHEIT** / **RESSORTS**
Dogbones Level mm

CAMBER ANGLE / **STURZ** / **ANGLE DE CORROSSAGE**
-1 °

DIFF. OIL / **DIFF. ÖL** / **HUILE DE DIFF.**
10,000 .wt

SWAY BAR / **STABILISATOR** / **BARRE ANTI-ROULI**
1.3 mm

SWAY BAR LINK / **STABILISATOR HEBELLANGE** / **LIEN DE LA BARRE ANTI-ROULI**
18 mm

WISHBONE DROOP / **AUSFEDERWEG** / **ACHSE DROOP DES TRIANGLES ARRIÈRES**
Maximum mm

NOTES / **NOTIZEN** / **NOTES**
LRP Diff Oil

MOTOR / **MOTOR** / **MOTEUR**
LRP X12 6.5t

SPUR GEAR / **HAUPTZAHNRAD** / **COURONNE**
87

PINION GEAR / **RITZEL** / **PIGNON**
22

BATTERY / **AKKU** / **BATTERIE**
LRP 4800 LIPo 40C

ESC SETTINGS / **REGLER PROGRAMM** / **RÉGLAGE DU VARIATEUR**
LRP 1-2-2-2

BALLAST POSITION / **GEWICHTSPOSITION** / **POSITION DES POIDS**
 SIDES SKIDPLATE

WING / **FLÜGEL** / **TYPE D'AILERON**
Kit

FRONT SHOCKS / VORNE DÄMPFER / AVANT AMORTISSEURS

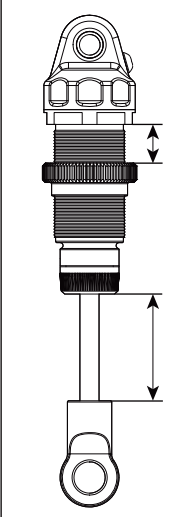

SPRINGS / **FEDERN** / **RESSORTS**
Dark Green

REBOUND / **REBOUND** / **REBOND**
0 %

PRELOAD / **FEDERVORSpannung** / **PRÉCONTRAINTÉ**
mm

OIL WT. / **ÖLVISKOSITÄT** / **GRADE HUILE**
20 Wt cST

PISTON / **KOLBEN** / **PISTON**
2 Hole

LENGTH / **LÄNGE** / **LONGUEUR**
1.5mm Limit Inside mm

NOTES / **NOTIZEN** / **NOTES**
Associated Oil

REAR SHOCKS / HINTEN DÄMPFER / ARRIÈRE AMORTISSEURS

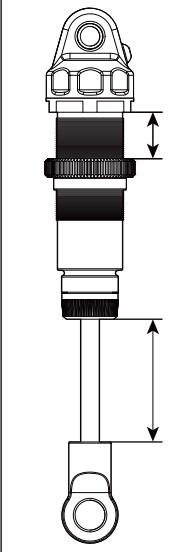

SPRINGS / **FEDERN** / **RESSORTS**
Grey

REBOUND / **REBOUND** / **REBOND**
0 %

PRELOAD / **FEDERVORSpannung** / **PRÉCONTRAINTÉ**
mm

OIL WT. / **ÖLVISKOSITÄT** / **GRADE HUILE**
20 Wt cST

PISTON / **KOLBEN** / **PISTON**
3 Hole

LENGTH / **LÄNGE** / **LONGUEUR**
No Limiter mm

NOTES / **NOTIZEN** / **NOTES**
Associated Oil

TYRES REIFEN PNEUS

FRONT	REAR
BRAND / HERSTELLER / MARQUE Pro-Line	BRAND / HERSTELLER / MARQUE Pro-Line
COMPOUND / MISCHUNG / GOMME M3	COMPOUND / MISCHUNG / GOMME M3
INSERT / EINLAGEN / INSERT Stock	INSERT / EINLAGEN / INSERT Stock
WHEEL / FELGE / JANTE Durango	WHEEL / FELGE / JANTE Durango
NOTES / NOTIZEN / NOTES	NOTES / NOTIZEN / NOTES

RESULTS / **PLATZIERUNG** / **RÉSULTAT**
QUALIFYING POSITION / VORLAUFERGBNIS / POSITION EN QUALIF: TQ
FINAL POSITION / ENDPATZIERUNG / POSITION EN FINALE: 1st

AVERAGE LAP / **DURCHSCHNITZTZEIT** / **TEMPS AU TOUR MOYEN**
BEST LAP / **SCHNELLSTE-RUNDE** / **MEILLEUR TEMPS AU TOUR**: 25.0
RACE TIME / **REINDAUER** / **DURÉE DE LA COURSE**

