

# TEAM DURANGO DEX410

# SETUP SHEET

NAME / NOM: Adam Skelding

DATE / DATUM: 12/07/2009

SETUP BLATT / FICHE DE RÉGLAGE V1.1 E

EVENT / VERANSTALTUNG: Mid-East Regional

TRACK / STRECKE: East Trax

AIR TEMP / UMGEBUNGSTEMP.: 20 °

TRACK SIZE / STRECKENGRÖSSE: Medium

SURFACE / STRECKENBELAG: Astro-Turf

TRACTION LEVEL / GRIFF: High

CONDITIONS / WETTER: Dry

## FRONT VORN AVANT

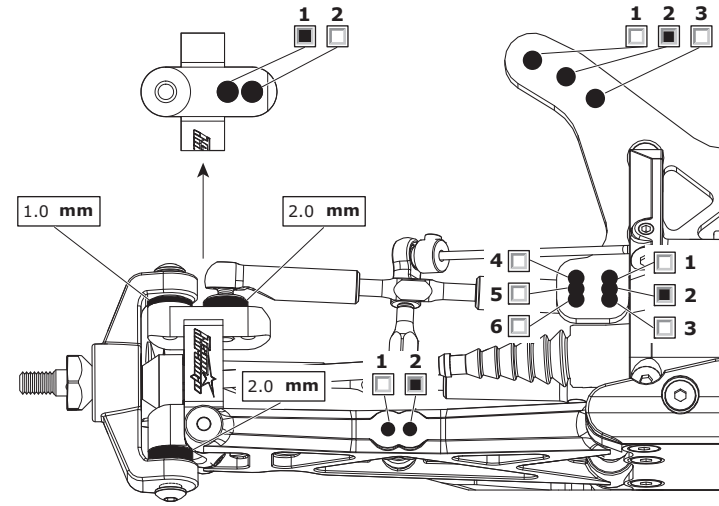

## REAR HINTEN ARRIÈRE

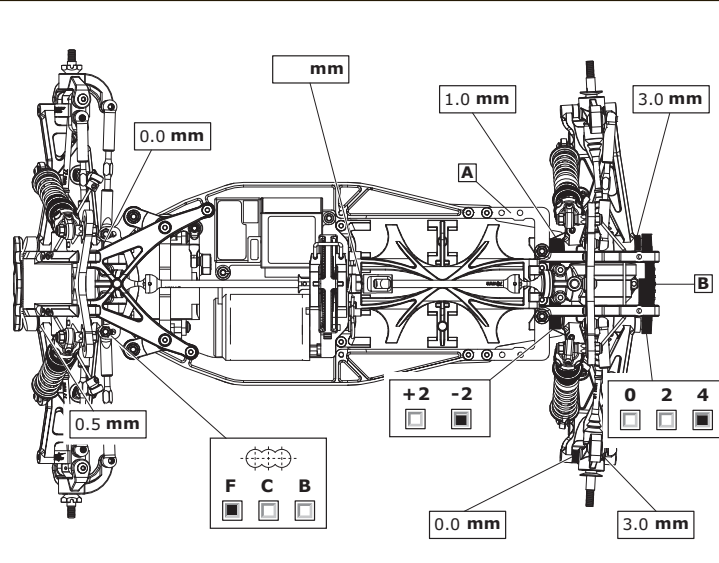
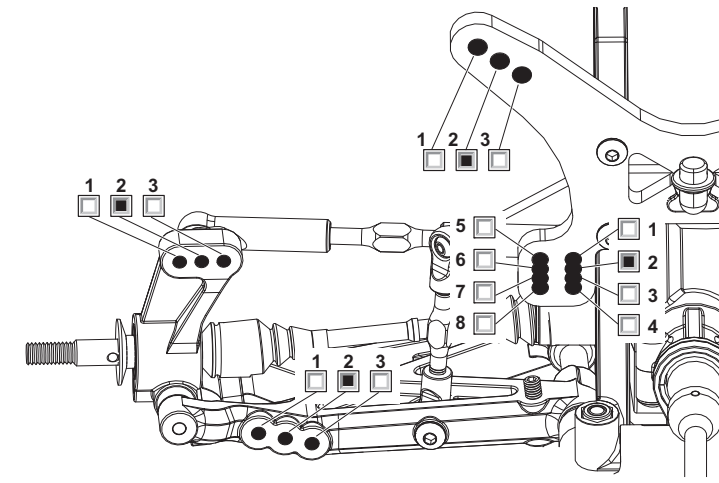

**RIDE HEIGHT** / **BODENFREIHEIT** / **RESSORTS**  
20 mm

**CAMBER ANGLE** / **STURZ** / **ANGLE DE CORROSSAGE**  
-1.5 °

**CASTOR ANGLE** / **NACHLAUF** / **ANGLE DE CHASSE**  
Kit °

**TOE IN/OUT** / **VONSPUR/NACHSPUR** / **ANGLE DE PINCEMENT**  
+/- 0 °

**DIFF. OIL** / **DIFF. ÖL** / **HUILE DE DIFF.**  
3,000 .wt

**SWAY BAR** / **STABILISATOR** / **BARRE ANTI-ROULI**  
None mm

**SWAY BAR LINK** / **STABILISATOR HEBELLANGE** / **LIEN DE LA BARRE ANTI-ROULI**  
mm

**NOTES** / **NOTIZEN** / **NOTES**

**RIDE HEIGHT** / **BODENFREIHEIT** / **RESSORTS**  
20 mm

**CAMBER ANGLE** / **STURZ** / **ANGLE DE CORROSSAGE**  
-1 °

**DIFF. OIL** / **DIFF. ÖL** / **HUILE DE DIFF.**  
1,000 .wt

**SWAY BAR** / **STABILISATOR** / **BARRE ANTI-ROULI**  
1.3 mm

**SWAY BAR LINK** / **STABILISATOR HEBELLANGE** / **LIEN DE LA BARRE ANTI-ROULI**  
None mm

**WISHBONE DROOP** / **AUSFEDERWEG** / **ACHSE** / **DROOP DES TRIANGLES ARRIÈRES**  
mm

**NOTES** / **NOTIZEN** / **NOTES**

**MOTOR** / **MOTOR** / **MOTEUR**  
Nosram Storm 6.5T (13.0mm)

**SPUR GEAR** / **HAUPTZAHNRAD** / **COURONNE**  
87

**PINION GEAR** / **RITZEL** / **PIGNON**  
23

**BATTERY** / **AKKU** / **BATTERIE**  
4600 LiPo (35C)

**ESC SETTINGS** / **REGLER PROGRAMM** / **RÉGLAGE DU VARIATEUR**

**BALLAST POSITION** / **GEWICHTSPOSITION** / **POSITION DES POIDS**  
 SIDES  SKIDPLATE

**WING** / **FLÜGEL** / **TYPE D'AILERON**  
DEX410

## FRONT SHOCKS / VORNE DÄMPFER / AVANT AMORTISSEURS

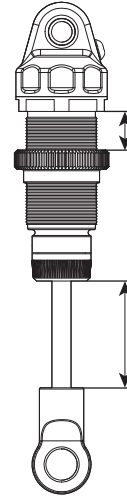

**SPRINGS** / **FEDERN** / **RESSORTS**  
Dark Blue

**REBOUND** / **REBOUND** / **REBOND**  
0 %

**PRELOAD** / **FEDERVORSpannung** / **PRÉCONTRAINTÉ**  
mm

**OIL WT.** / **ÖLVISKOSITÄT** / **GRADE HUILE**  
450 cST

**PISTON** / **KOLBEN** / **PISTON**  
2 Hole

**LENGTH** / **LÄNGE** / **LONGUEUR**  
mm

**NOTES** / **NOTIZEN** / **NOTES**

## REAR SHOCKS / HINTEN DÄMPFER / ARRIÈRE AMORTISSEURS

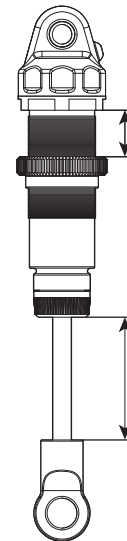

**SPRINGS** / **FEDERN** / **RESSORTS**  
Light Blue

**REBOUND** / **REBOUND** / **REBOND**  
0 %

**PRELOAD** / **FEDERVORSpannung** / **PRÉCONTRAINTÉ**  
mm

**OIL WT.** / **ÖLVISKOSITÄT** / **GRADE HUILE**  
300 cST

**PISTON** / **KOLBEN** / **PISTON**  
3 Hole

**LENGTH** / **LÄNGE** / **LONGUEUR**  
mm

**NOTES** / **NOTIZEN** / **NOTES**

## TYRES REIFEN PNEUS

FRONT	REAR
<b>BRAND</b> / <b>HERSTELLER</b> / <b>MARQUE</b> Schumacher	<b>BRAND</b> / <b>HERSTELLER</b> / <b>MARQUE</b> Schumacher
<b>COMPOUND</b> / <b>MISCHUNG</b> / <b>GOMME</b> Yellow	<b>COMPOUND</b> / <b>MISCHUNG</b> / <b>GOMME</b> Yellow
<b>INSERT</b> / <b>EINLAGEN</b> / <b>INSERT</b> Edit Purple	<b>INSERT</b> / <b>EINLAGEN</b> / <b>INSERT</b> Edit Purple
<b>WHEEL</b> / <b>FELGE</b> / <b>JANTE</b> DEX410 White	<b>WHEEL</b> / <b>FELGE</b> / <b>JANTE</b> DEX410 White
<b>NOTES</b> / <b>NOTIZEN</b> / <b>NOTES</b> 1 Degree Rear Hubs	

**RESULTS** / **PLATZIERUNG** / **RÉSULTAT**  
QUALIFYING POSITION / VORLAUFERGERBNIS / POSITION EN QUALIF: 2nd  
FINAL POSITION / ENDPATZIERUNG / POSITION EN FINALE: 7th

**AVERAGE LAP** / **DURCHSCHNITZITZEIT** / **TEMPS AU TOUR MOYEN**  
**BEST LAP** / **SCHNELLSTE-RUNDE** / **MEILLEUR TEMPS AU TOUR**  
**RACE TIME** / **REINWAUER** / **DURÉE DE LA COURSE**

