

TEAM DURANGO DEX410

SETUP SHEET

NAME / NOM: Adam Skelding

DATE / DATUM: 30/08/2009

SETUP BLATT / FICHE DE RÉGLAGE V1.1 E

EVENT / VERANSTALTUNG: European Championships 2009

TRACK / STRECKE: Bilbao, Spain

AIR TEMP / UMGEBUNGSTEMP.: 29 °

TRACK SIZE / STRECKENGRÖSSE: Large

SURFACE / STRECKENBELAG: 90% Astro, 10% Dirt

TRACTION LEVEL / GRIFF: High

CONDITIONS / WETTER: Dry

RIDE HEIGHT / BODENFREIHEIT

RESSORTS: 20 mm

CAMBER ANGLE / STURZ

ANGLE DE CORROSSAGE: -1 °

CASTOR ANGLE / NACHLAUF

ANGLE DE CHASSE: Kit

TOE IN/OUT / VONSPUR/NACHSPUR

ANGLE DE PINCEMENT: +/- 0

DIFF. OIL / DIFF. ÔL

HUILE DE DIFF.: 10,000 .wt

SWAY BAR / STABILISATOR

BARRE ANTI-ROULI: None mm

SWAY BAR LINK / STABILISATOR HEBELLANGE

LIEN DE LA BARRE ANTI-ROULI: N/A mm

NOTES / NOTIZEN

NOTES

FRONT VORN AVANT

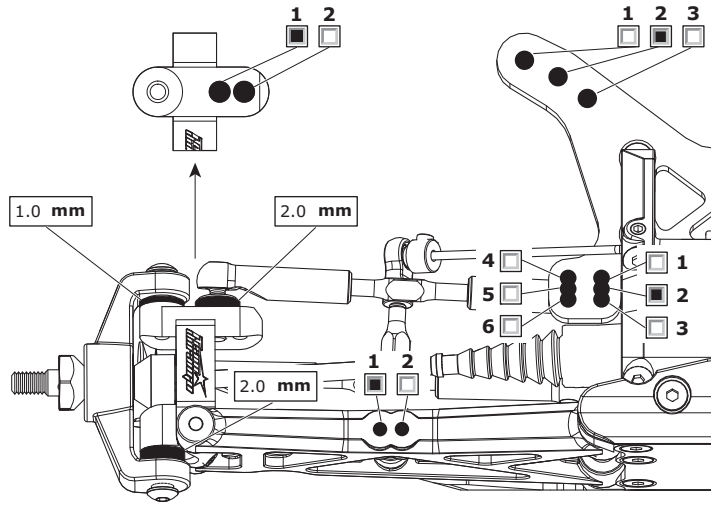

RIDE HEIGHT / BODENFREIHEIT

RESSORTS: 20 mm

CAMBER ANGLE / STURZ

ANGLE DE CORROSSAGE: -1.0 °

DIFF. OIL / DIFF. ÔL

HUILE DE DIFF.: 3,000 .wt

SWAY BAR / STABILISATOR

BARRE ANTI-ROULI: 1.3 mm

SWAY BAR LINK / STABILISATOR HEBELLANGE

LIEN DE LA BARRE ANTI-ROULI: 18.0 mm

WISHBONE DROOP / AUSFEDERWEG

ACHSE / DROOP DES TRIANGLES ARRIÈRES: Max mm

NOTES / NOTIZEN

NOTES

REAR HINTEN ARRIÈRE

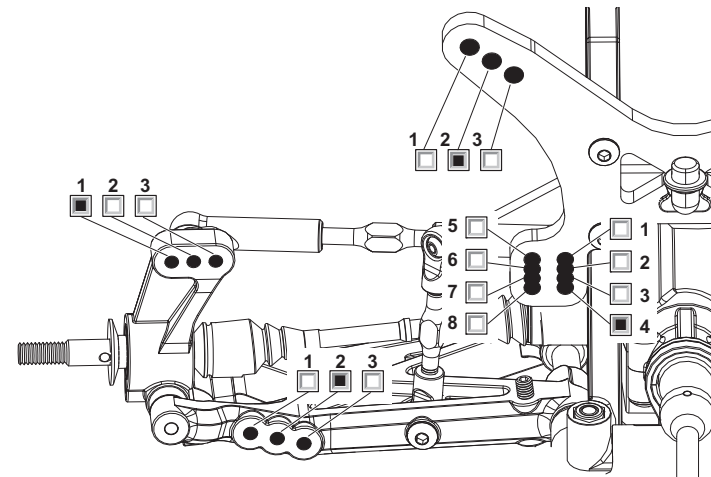

MOTOR / MOTOR

MOTEUR: Nosram Pure 5.5T

SPUR GEAR / HAUPTZAHNRAD

COURONNE: 87T

PINION GEAR / RITZEL

PIGNON: 20T

BATTERY / AKKU

BATTERIE: Yuntong 4600 (35C)

ESC SETTINGS / REGLER PROGRAMM

RÉGLAGE DU VARIATEUR: Nosram : 2-2-0-0

BALLAST POSITION / GEWICHTSPOSITION

POSITION DES POIDS: SIDES SKIDPLATE

WING / FLÜGEL

TYPE D'AILERON: DEX410

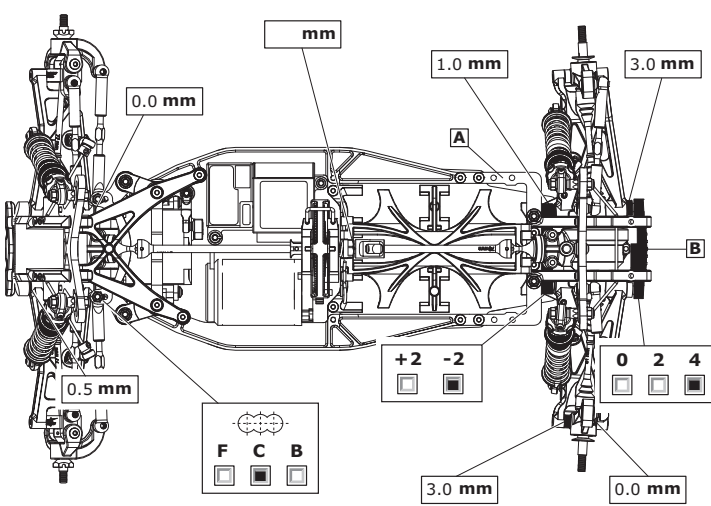

FRONT SHOCKS / VORNE DÄMPFER

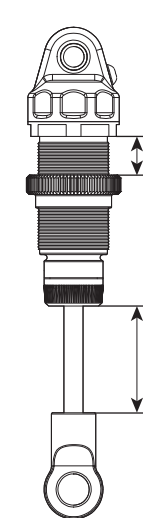

SPRINGS / FEDERN RESSORTS: Dark Blue

REBOUND / REBOUND REBOND: 25 %

PRELOAD / FEDERVORSpannung PRÉCONTRAINTÉ: mm

OIL WT. / ÖLVISKOSITÄT GRADE HUILE: 550 cST

PISTON / KOLBEN PISTON: 2 Hole

LENGTH / LÄNGE LONGUEUR: mm

NOTES / NOTIZEN NOTES: Shock Boots

REAR SHOCKS / HINTEN DÄMPFER

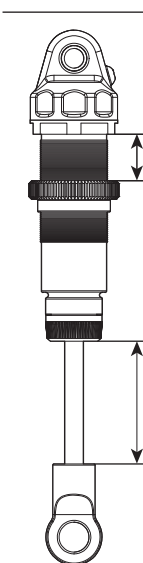

SPRINGS / FEDERN RESSORTS: Light Green

REBOUND / REBOUND REBOND: 25 %

PRELOAD / FEDERVORSpannung PRÉCONTRAINTÉ: mm

OIL WT. / ÖLVISKOSITÄT GRADE HUILE: 350 cST

PISTON / KOLBEN PISTON: 2 x 1.3mm, 1 x 1.2mm

LENGTH / LÄNGE LONGUEUR: mm

NOTES / NOTIZEN NOTES: Shock Boots

TYRES / REIFEN / PNEUS

FRONT	REAR
BRAND / HERSTELLER MARQUE: Schumacher	Schumacher
COMPOUND / MISCHUNG GOMME: Yellow	Yellow
INSERT / EINLAGEN INSERT: KangaWallaFox	KanagaWallaFox
WHEEL / FELGE JANTE: DEX410 White	DEX410 White
NOTES / NOTIZEN NOTES: Ins & Out 2 Rows off Front. Ins & Out Rows off Rear.	

RESULTS / PLATZIERUNG / RÉSULTAT QUALIFYING POSITION / VORLAUFERGERBNIS: 19th FINAL POSITION / ENDPATZIERUNG: 14th

AVERAGE LAP / DURCHSCHNITTSZEIT TEMPS AU TOUR MOYEN: BEST LAP / SCHNELLSTE-RUNDE: MEILLEUR TEMPS AU TOUR: RACE TIME / RENWDAUER: DURÉE DE LA COURSE

