

TEAM DURANGO DEX410 SETUP SHEET

PRINT

SUBMIT

NAME / NOM: Adam Skelding

DATE / DATUM: 13/09/2009

SETUP BLATT / FICHE DE RÉGLAGE V1.3 E

EVENT / VERANSTALTUNG: Club Points Meeting

TRACK / STRECKE: Batley (Outdoor) Spenborough Sports Centre

AIR TEMP / UMGEBUNGSTEMP.: 17 °C

TRACK SIZE / STRECKENGRÖSSE: Med/Large

SURFACE / STRECKENBELAG: 50% Grass 50% Astro

TRACTION LEVEL / GRIFF: Medium

CONDITIONS / WETTER: Dry

RIDE HEIGHT
BODENFREIHEIT / GARDE AU SOL: 19 mm

CAMBER ANGLE
STURZ / ANGLE DE CARROSSAGE: -1 °

CASTOR ANGLE
NACHLAUF / ANGLE DE CHASSE: Kit °

TOE IN/OUT
VONSPUR/NACHSPUR / ANGLE DE PINCEMENT: +/- 0 mm

DIFF. OIL
DIFF. ÖL / HUILE DE DIFF.: 10,000 .wt

SWAY BAR
STABILISATOR / BARRE ANTI-ROULIS: None mm

SWAY BAR LINK
STABILISATOR HEBELLANGE / LIEN DE LA BARRE ANTI-ROULIS: N/A mm

NOTES
NOTIZEN / REMARQUES:

FRONT VORN AVANT

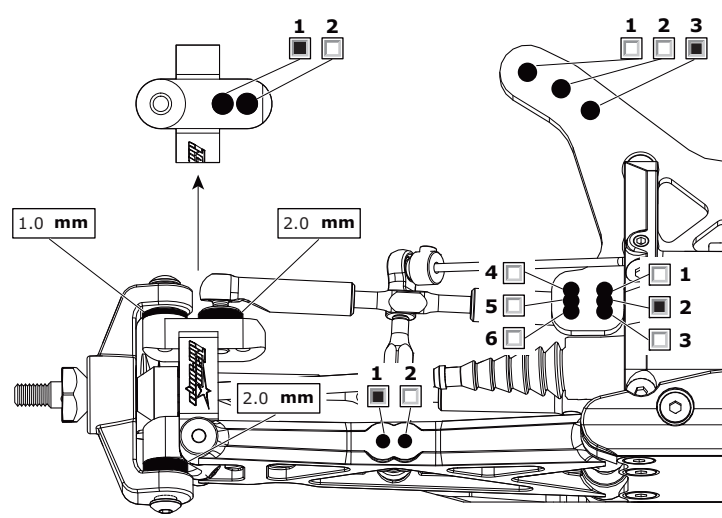

RIDE HEIGHT
BODENFREIHEIT / GARDE AU SOL: 19 mm

CAMBER ANGLE
STURZ / ANGLE DE CORROSSAGE: -1.5 °

DIFF. OIL
DIFF. ÖL / HUILE DE DIFF.: 5,000 .wt

SWAY BAR
STABILISATOR / BARRE ANTI-ROULIS: 1.3 mm

SWAY BAR LINK
STABILISATOR HEBELLANGE / LIEN DE LA BARRE ANTI-ROULIS: 18.0 mm

WISHBONE DROOP
AUSFEDERWEG / DROOP DES TRIANGLES ARRIÈRES: Max (With Screw in) mm

NOTES
NOTIZEN / REMARQUES:

REAR HINTEN ARRIÈRE

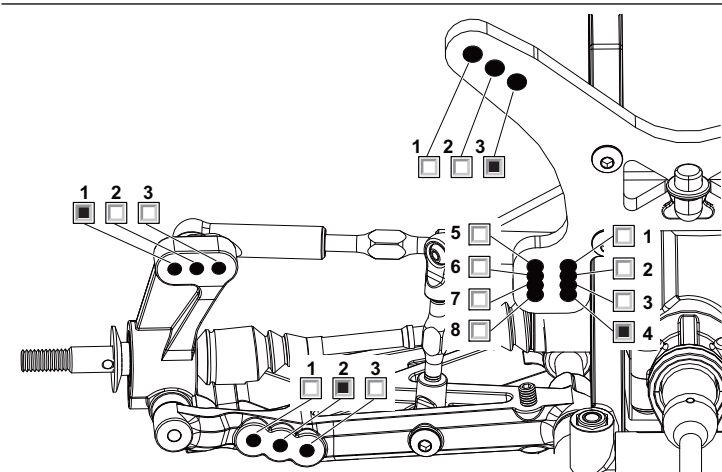

MOTOR
MOTOR / MOTEUR:

SPUR GEAR
HAUPTZAHNRAD / COURONNE:

PINION GEAR
RITZEL / PIGNON:

BATTERY
AKKU / ACCUMULATEUR:

ESC SETTINGS
REGLER PROGRAMM / RÉGLAGE DU VARIATEUR:

BALLAST POSITION
GEWICHTSPOSITION / POSITION DES LEST:
 SIDES SKIDPLATE

WING
FLÜGEL / TYPE D'AILERON:

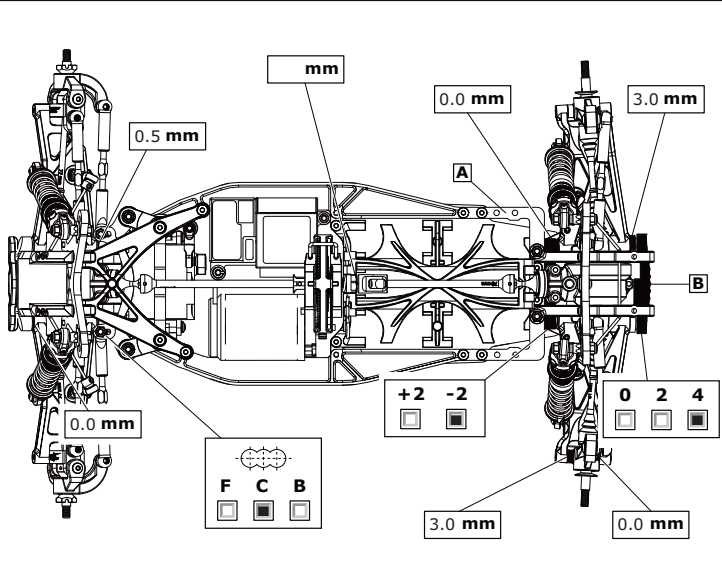

FRONT SHOCKS VORNE DÄMPFER / AVANT AMORTISSEURS

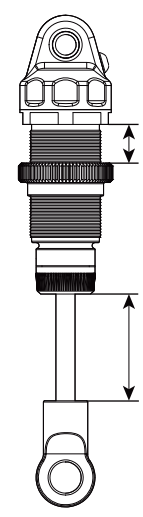

SPRINGS
FEDERN / RESSORTS: Dark Blue

REBOUND
REBOUND / REBOND: 0 %

PRELOAD
FEDERVORSpannung / PRÉCONTRAINTÉ: mm

OIL WT.
ÖLVISKOSITÄT / GRADE HUILE: 500 cST

PISTON
KOLBEN / PISTON: 2 Hole

LENGTH
LÄNGE / LONGUEUR: mm

NOTES
NOTIZEN / REMARQUES: Shock Boots

REAR SHOCKS HINTEN DÄMPFER / ARRIÈRE AMORTISSEURS

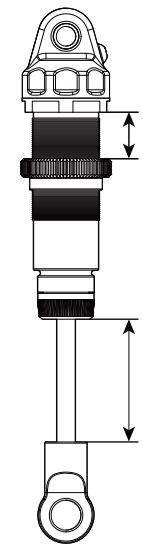

SPRINGS
FEDERN / RESSORTS: Light Green

REBOUND
REBOUND / REBOND: 0 %

PRELOAD
FEDERVORSpannung / PRÉCONTRAINTÉ: mm

OIL WT.
ÖLVISKOSITÄT / GRADE HUILE: 400 cST

PISTON
KOLBEN / PISTON: 3 x 1.4mm (Drilled)

LENGTH
LÄNGE / LONGUEUR: mm

NOTES
NOTIZEN / REMARQUES: Shock Boots

TYRES REIFEN PNEUS

FRONT	REAR
BRAND / HERSTELLER / MARQUE: Schumacher	Schumacher
COMPOUND / MISCHUNG / COMPOUND: Yellow	Yellow
INSERT / EINLAGEN / INSERT: Edit Purple	Edit Purple
WHEEL / FELGE / JANTE: DEX410 White	DEX410 White
NOTES / NOTIZEN / REMARQUES: Front: I/O 2 Rows off. Rear: I/O Row off.	

RESULTS PLATZIERUNG RÉSULTAT
 QUALIFYING POSITION / VORLAUFERGBNIS / POSITION EN QUALIFICATION: 2nd
 FINAL POSITION / ENDPLATZIERUNG / POSITION FINALE: 1st
 AVERAGE LAP / DURCHSCHNITZTZEIT / TEMPS AU TOUR MOYEN: 24.84
 BEST LAP / SCHNELLSTE-RUNDE / MEILLEUR TEMPS AU TOUR: 23.59
 RACE TIME / RENWDAUER / DURÉE DE LA COURSE:

