

# TEAM DURANGO DEX410

# SETUP SHEET

NAME / NOM: Adam Skelding DATE / DATUM: 30/08/2009

SETUP BLATT FICHE DE RÉGLAGE V1.1 E AIR TEMP / UMGEBUNGSTEMP.: 19 °

EVENT / VERANSTALTUNG: BRCA 4wd National Round 6 TRACK / STRECKE: Robin Hood Raceway

TRACK SIZE / STRECKENGRÖSSE: Large SURFACE / STRECKENBELAG: 100% Astro TRACTION LEVEL / GRIFF: High CONDITIONS / WETTER: Dry

## FRONT VORN AVANT

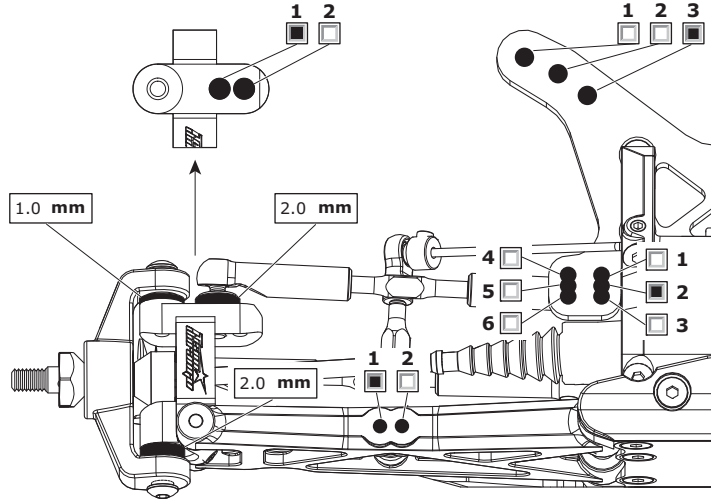

## REAR HINTEN ARRIÈRE

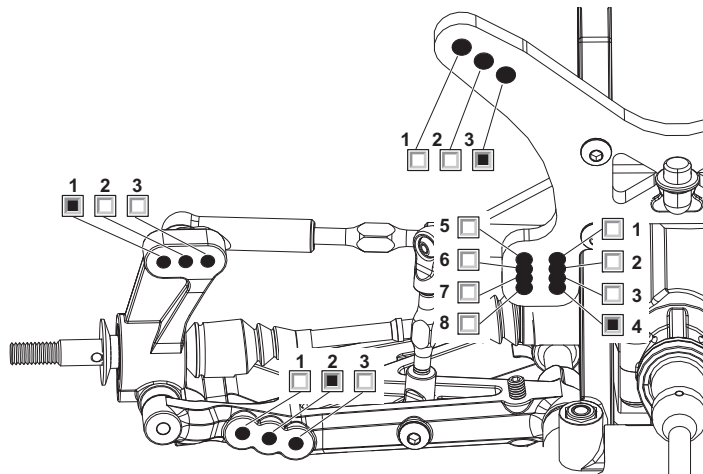

**RIDE HEIGHT** / **BODENFREIHEIT** / **RESSORTS**  
19 mm

**CAMBER ANGLE** / **STURZ** / **ANGLE DE CORROSSAGE**  
-1 °

**CASTOR ANGLE** / **NACHLAUF** / **ANGLE DE CHASSE**  
Kit °

**TOE IN/OUT** / **VONSPUR/NACHSPUR** / **ANGLE DE PINCEMENT**  
+/- 0 °

**DIFF. OIL** / **DIFF. ÖL** / **HUILE DE DIFF.**  
10,000 .wt

**SWAY BAR** / **STABILISATOR** / **BARRE ANTI-ROULI**  
None mm

**SWAY BAR LINK** / **STABILISATOR HEBELLANGE** / **LIEN DE LA BARRE ANTI-ROULI**  
N/A mm

**NOTES** / **NOTIZEN** / **NOTES**

**RIDE HEIGHT** / **BODENFREIHEIT** / **RESSORTS**  
19 mm

**CAMBER ANGLE** / **STURZ** / **ANGLE DE CORROSSAGE**  
-1.0 °

**DIFF. OIL** / **DIFF. ÖL** / **HUILE DE DIFF.**  
3,000 .wt

**SWAY BAR** / **STABILISATOR** / **BARRE ANTI-ROULI**  
1.3 mm

**SWAY BAR LINK** / **STABILISATOR HEBELLANGE** / **LIEN DE LA BARRE ANTI-ROULI**  
18.0 mm

**WISHBONE DROOP** / **AUSFEDERWEG AXCHSE** / **DROOP DES TRIANGLES ARRIÈRES**  
Max mm

**NOTES** / **NOTIZEN** / **NOTES**

**MOTOR** / **MOTOR** / **MOTEUR**  
Nosram Pure 5.5T

**SPUR GEAR** / **HAUPTZAHNRAD** / **COURONNE**  
87T

**PINION GEAR** / **RITZEL** / **PIGNON**  
20T

**BATTERY** / **AKKU** / **BATTERIE**  
Yuntong 4600 (35C)

**ESC SETTINGS** / **REGLER PROGRAMM** / **RÉGLAGE DU VARIATEUR**  
Nosram : 2-2-0-0

**BALLAST POSITION** / **GEWICHTSPOSITION** / **POSITION DES POIDS**  
 SIDES  SKIDPLATE

**WING** / **FLÜGEL** / **TYPE D'AILERON**  
DEX410

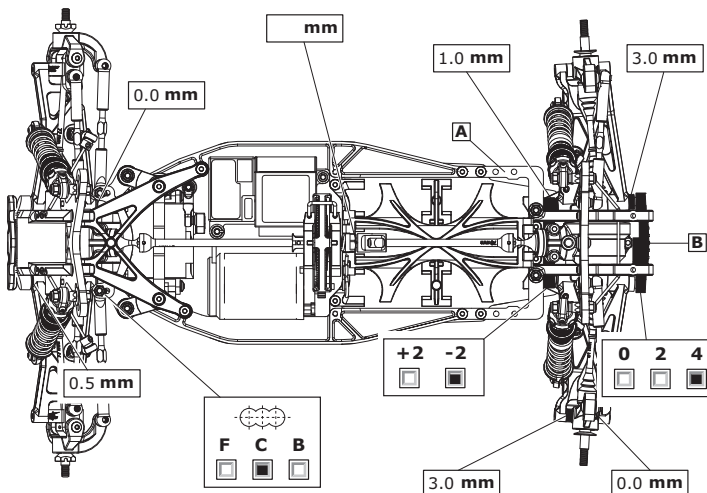

**RESULTS PLATZIERUNG RÉSULTAT** QUALIFYING POSITION / VORLAUFERGERBNIS / POSITION EN QUALIF: 18th FINAL POSITION / ENDPATZIERUNG / POSITION EN FINALE: 15th

AVERAGE LAP / DURCHSCHNITZTZEIT / TEMPS AU TOUR MOYEN: BEST LAP / SCHNELLSTE-RUNDE / MEILLEUR TEMPS AU TOUR: RACE TIME / RENWDAUER / DURÉE DE LA COURSE:

## FRONT SHOCKS VORNE DÄMPFER AVANT AMORTISSEURS

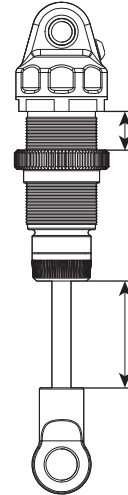

**SPRINGS** / **FEDERN** / **RESSORTS**  
Dark Green

**REBOUND** / **REBOUND** / **REBOND**  
25 %

**PRELOAD** / **FEDERVORSpannung** / **PRÉCONTRAINTÉ**  
mm

**OIL WT.** / **ÖLVISKOSITÄT** / **GRADE HUILE**  
450 cST

**PISTON** / **KOLBEN** / **PISTON**  
2 Hole

**LENGTH** / **LÄNGE** / **LONGUEUR**  
mm

**NOTES** / **NOTIZEN** / **NOTES**  
Shock Boots

## REAR SHOCKS HINTEN DÄMPFER ARRIÈRE AMORTISSEURS

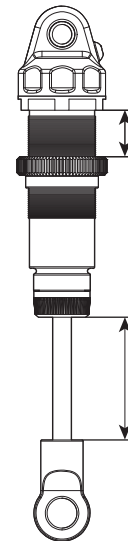

**SPRINGS** / **FEDERN** / **RESSORTS**  
Light Green

**REBOUND** / **REBOUND** / **REBOND**  
25 %

**PRELOAD** / **FEDERVORSpannung** / **PRÉCONTRAINTÉ**  
mm

**OIL WT.** / **ÖLVISKOSITÄT** / **GRADE HUILE**  
350 cST

**PISTON** / **KOLBEN** / **PISTON**  
2 x 1.3mm, 1 x 1.2mm

**LENGTH** / **LÄNGE** / **LONGUEUR**  
mm

**NOTES** / **NOTIZEN** / **NOTES**  
Shock Boots

## TYRES REIFEN PNEUS

FRONT	REAR
<b>BRAND</b> / <b>HERSTELLER</b> / <b>MARQUE</b> Schumacher	Schumacher
<b>COMPOUND</b> / <b>MISCHUNG</b> / <b>GOMME</b> Yellow	Yellow
<b>INSERT</b> / <b>EINLAGEN</b> / <b>INSERT</b> KangaWallaFox	KanagaWallaFox
<b>WHEEL</b> / <b>FELGE</b> / <b>JANTE</b> DEX410 White	DEX410 White
<b>NOTES</b> / <b>NOTIZEN</b> / <b>NOTES</b> Ins & Out 2 Rows off Front. Ins & Out Rows off Rear.	

