

NAME NAME NOM **DATE** DATUM DATE **SETUP BLATT** **FICHE DE RÉGLAGE** **V1.0 E**
EVENT/TRACK VERANSTALTUNG/STREKE EVENEMENT/PISTE **SURFACE** STRECKENBELAG TYPE DE SURFACE **TRACTION LEVEL** GRIFF ADHÉRENCE
CONDITIONS WETTER NIVEAU D'HYDROMÉTRIE **AIR TEMP** UMGEBUNGSTEMP. TEMPÉRATURE DE L'AIR **QUALIFYING POSITION** VORLAUFERGEBNIS POSITION EN QUALIFICATION **FINAL POSITION** ENDPLATZIERUNG POSITION FINALE

RIDE HEIGHT **BODENFREIHEIT** GARDE AU SOL mm

CAMBER ANGLE **STURZ** ANGLE DE CARROSSAGE °

TOE IN/OUT **VONSPUR/NACHSPUR** ANGLE DE PINCEMENT +/- °

WISHBONE DROOP* **AUSFEDERWEG/ACHSE** **DROOP DES TRIANGLES ARRIÈRES** mm

NOTES **NOTIZEN** **REMARQUES**

FRONT VORN AVANT

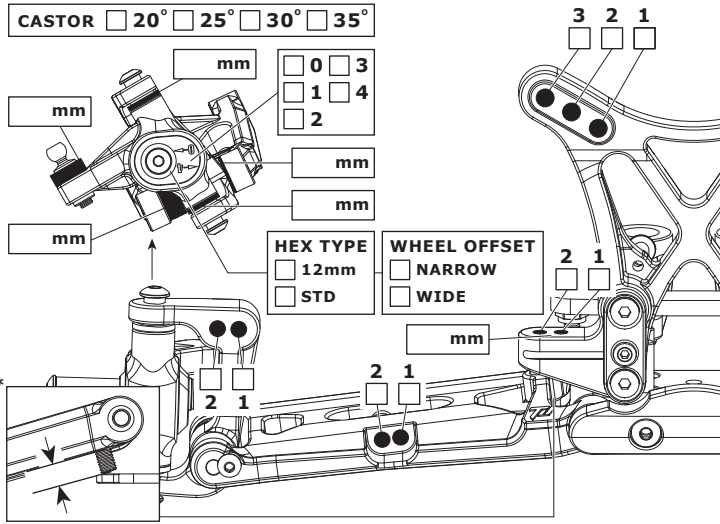

RIDE HEIGHT **BODENFREIHEIT** GARDE AU SOL mm

CAMBER ANGLE **STURZ** ANGLE DE CORROSSAGE °

WISHBONE DROOP* **AUSFEDERWEG/ACHSE** **DROOP DES TRIANGLES ARRIÈRES** mm

NOTES **NOTIZEN** **REMARQUES**

REAR HINTEN ARRIÈRE

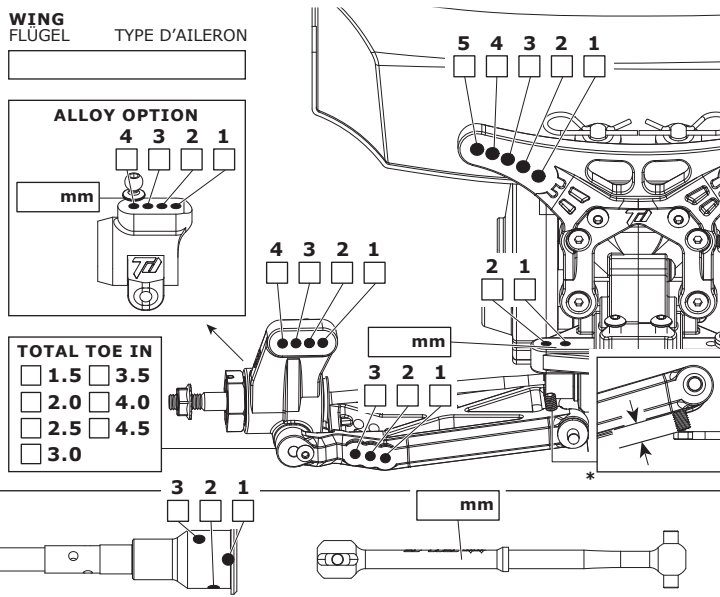

MOTOR **MOTOR** **MOTEUR**

SPUR GEAR **HAUPTZAHNRAD** **COURONNE**

PINION GEAR **RITZEL** **PIGNON**

BATTERY **AKKU** **ACCUMULATEUR**

ESC SETTINGS **REGLER PROGRAMM** **RÉGLAGE DU VARIATEUR**

DIFF TYPE **DIFF TYP** TYPE DE DIFF BALL 2 GEAR 4 GEAR

DIFF OIL **DIFF ÖL** **HUILE DE DIFF** cst

BODY **KÖRPER** **CARROSSERIE**

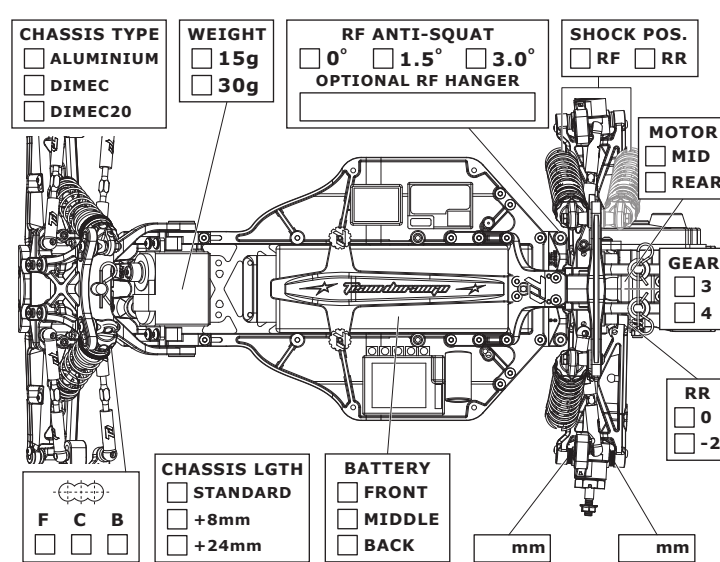

FRONT SHOCKS **VORNE DÄMPFER** **AMORTISSEURS AVANTS**

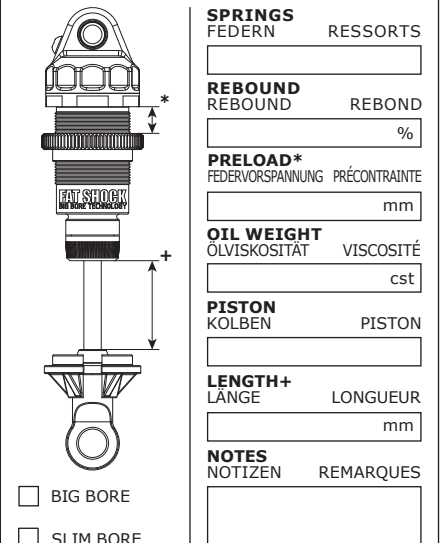

REAR SHOCKS **HINTEN DÄMPFER** **AMORTISSEURS ARRIÈRES**

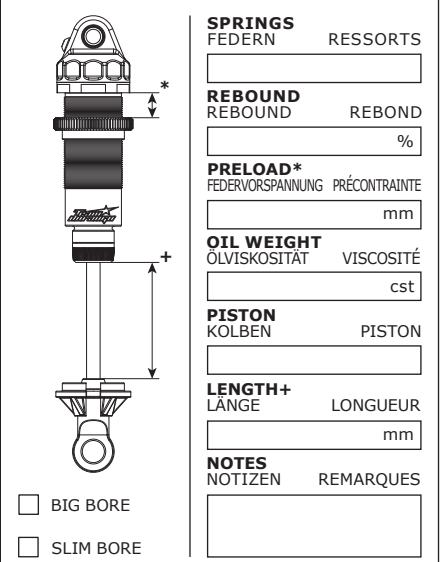

TYRES REIFEN PNEUS

FRONT	REAR	
BRAND	HERSTELLER	MARQUE
<input type="text"/>	<input type="text"/>	<input type="text"/>
TREAD	PROFIL	PROFIL
<input type="text"/>	<input type="text"/>	<input type="text"/>
COMPOUND	MISCHUNG	DURETÉ
<input type="text"/>	<input type="text"/>	<input type="text"/>
INSERT	EINLAGEN	MOUSSE
<input type="text"/>	<input type="text"/>	<input type="text"/>
WHEEL	FELGE	JANTE
<input type="text"/>	<input type="text"/>	<input type="text"/>
NOTES	NOTIZEN	REMARQUES
<input type="text"/>	<input type="text"/>	<input type="text"/>

