

NAME
NOM NAME craig collinson

DATE
DATUM DATE 27/07/2013

SETUP BLATT FICHE DE RÉGLAGE V1.0 E

EVENT
VERANSTALTUNG EVENT brca national rd 5

TRACK
STRECKE PISTE stotfold

AIR TEMP
UMGEBUNGSTEMP. TEMPÉRATURE DE L'AIR °

TRACK SIZE
STRECKENGRÖSSE TAILLE DE LA PISTE medium

SURFACE
STRECKENBELAG TYPE DE SURFACE astro

TRACTION LEVEL
GRIFF ADHÉRENCE high

CONDITIONS
WETTER NIVEAU D'HYDROMÉTRIE dry

RIDE HEIGHT
BODENFREIHEIT GARDE AU SOL
22 mm

CAMBER ANGLE
STURZ ANGLE DE CARROSSAGE
-1 °

TOE IN/OUT
VONSPUR/NACHSPUR ANGLE DE PINCEMENT
+/- 0 °

WISHBONE DROOP
AUSFEDERWEG/ACHSE DROOP DES TRIANGLES ARRIÈRES
max mm

SWAY BAR
STABILISATOR BARRE ANTI-ROULIS
None mm

SWAY BAR LINK
STABILISATORHEBELLENGE LIEN DE LA BARRE ANTI-ROULIS
n/a mm

NOTES
NOTIZEN REMARQUES

none

FRONT VORN AVANT

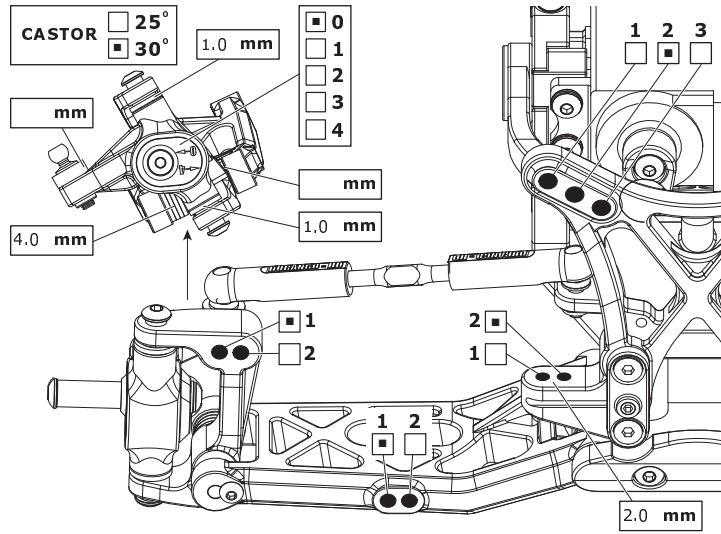

RIDE HEIGHT
BODENFREIHEIT GARDE AU SOL
22 mm

CAMBER ANGLE
STURZ ANGLE DE CARROSSAGE
-1 °

SWAY BAR
STABILISATOR BARRE ANTI-ROULIS
None mm

SWAY BAR LINK
STABILISATORHEBELLENGE LIEN DE LA BARRE ANTI-ROULIS
n/a mm

WISHBONE DROOP
AUSFEDERWEG/ACHSE DROOP DES TRIANGLES ARRIÈRES
max mm

NOTES
NOTIZEN REMARQUES

+8 chassis used with lipos side by side, 6mm lower rear tower.

REAR HINTEN ARRIÈRE

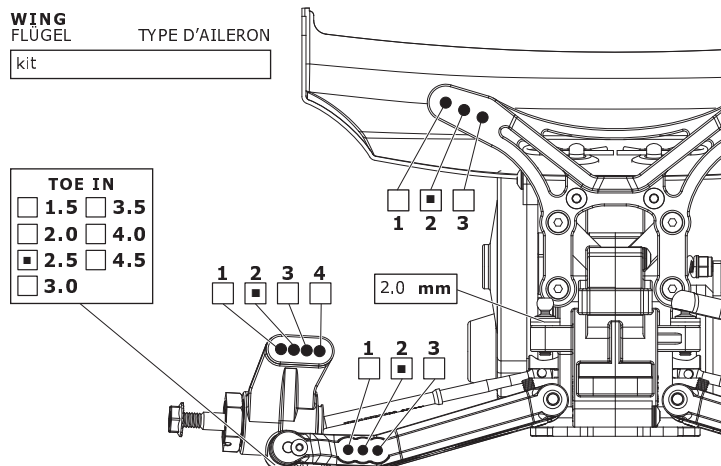

MOTOR MOTOR MOTEUR
hpi flux pro 6.5

SPUR GEAR
HAUPTZAHNRAD COURONNE
81

PINION GEAR
RITZEL PIGNON
22

BATTERY
AKKU ACCUMULATEUR
hpi flux pro

ESC SETTINGS
REGLER PROGRAMM RÉGLAGE DU VARIATEUR
kit

DIFF. TYPE
DIFF. TYP TYPE DE DIFF.
 BALL
 GEAR

DIFF. OIL
DIFF. ÖL HUILE DE DIFF.
600 cst

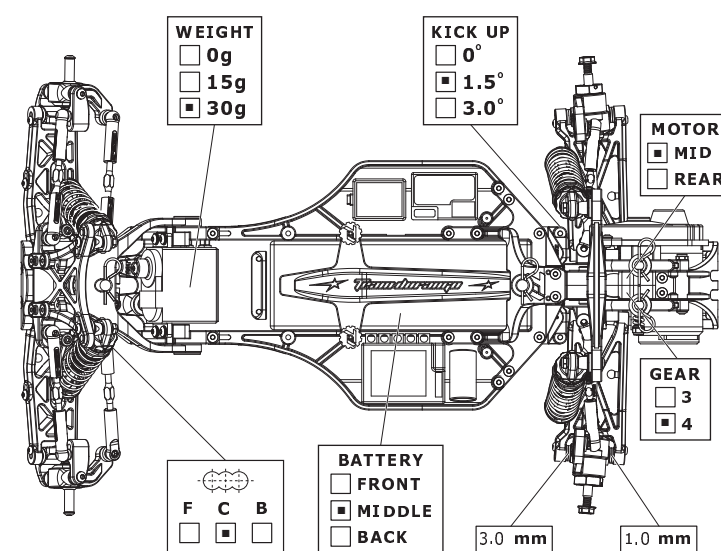

FRONT SHOCKS

VORNE DÄMPFER AVANT AMORTISSEURS



REAR SHOCKS

HINTEN DÄMPFER ARRIÈRE AMORTISSEURS

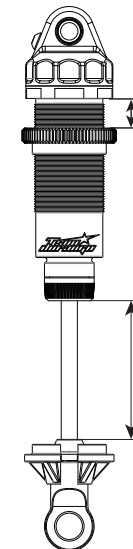

TYRES REIFEN PNEUS

FRONT		REAR	
BRAND	HERSTELLER	MARQUE	
schumacher		ballistic	
TREAD	PROFIL	PROFIL	
stagers		minispike	
COMPOUND	MISCHUNG	DURETÉ	
yellow		white	
INSERT	EINLAGEN	MOUSSE	
none		dboots medium	
WHEEL	FELGE	JANTE	
kit yellow		kit yellow	
NOTES	NOTIZEN	REMARQUES	
none			

RESULTS PLATZIERUNG RÉSULTAT QUALIFYING POSITION VORLAUFERGEBNIS POSITION EN QUALIFICATION FINAL POSITION ENDPLATZIERUNG POSITION FINALE

AVERAGE LAP DURCHSCHNITTSZEIT TEMPS AU TOUR MOYEN BEST LAP SCHNELLSTE RÜNDE MEILLEUR TEMPS AU TOUR RACE TIME REINDAUER DURÉE DE LA COURSE