

## Setup Sheet

Driver: \_\_\_\_\_ Event: \_\_\_\_\_  
 Date: \_\_\_\_\_ Track: \_\_\_\_\_  
 Quality: \_\_\_\_\_ TQ:  Main: \_\_\_\_\_ Finish: \_\_\_\_\_ Best Lap Time: \_\_\_\_\_

Front Suspension

Ride Height: \_\_\_\_\_  
 Camber: \_\_\_\_\_  
 Toe: \_\_\_\_\_  
 Anti-Roll Bar: \_\_\_\_\_  
 Wheelbase Shim: \_\_\_\_\_  
 Wheel Hex: \_\_\_\_\_  
 Caster Block: \_\_\_\_\_  
 Arm Stiffener: Yes  No

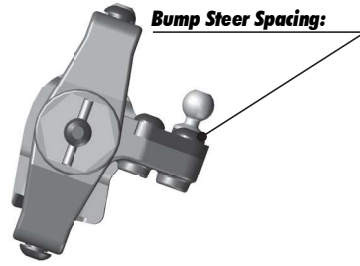

**FF Suspension Holder**  
 Alu  Brass  1°  0.5°



**FR Suspension Holder**  
 Alu  Brass  1°  0.5°

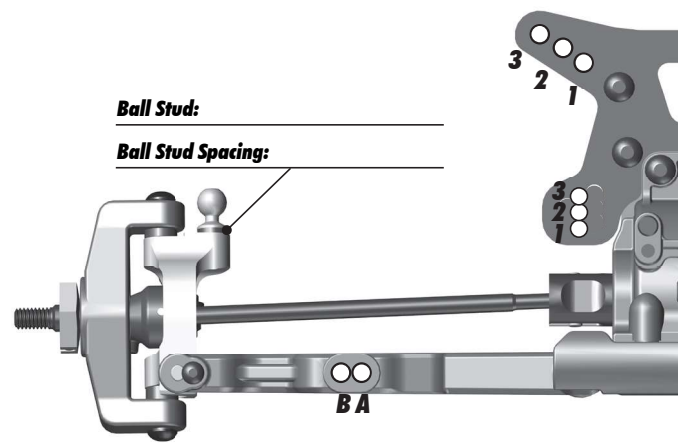
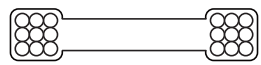

Notes

Rear Suspension

Ride Height: \_\_\_\_\_  
 Camber: \_\_\_\_\_  
 Anti-Roll Bar: \_\_\_\_\_  
 Wheel Hex: \_\_\_\_\_  
 Hub Spacing: Forward  Middle  Back   
 Arm Spacing: Forward  Back   
 Arm Stiffener: Yes  No   
 Chassis Stiffener: Std  Carbon

**Rear Chassis Stiffener Screws** → Front

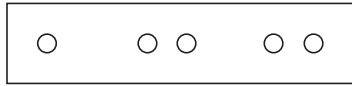

**RF Suspension Holder**  
 Alu  Brass  1°  0.5°

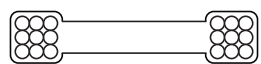

**RR Suspension Holder**  
 Alu  Brass  1°  0.5°

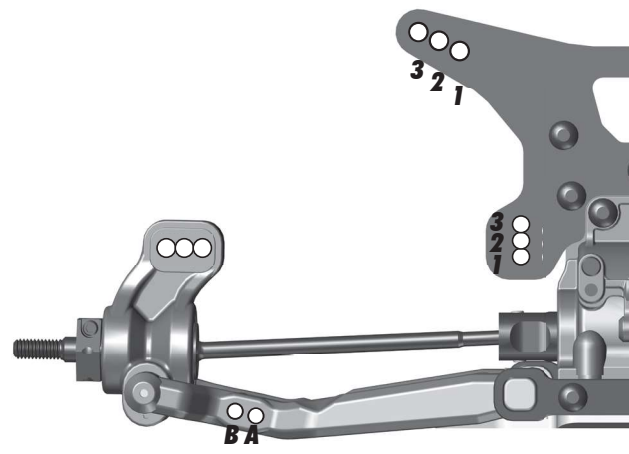
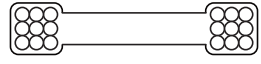

Notes

Electronics, Drivetrain & Shocks

**Radio:** \_\_\_\_\_ **Servo:** \_\_\_\_\_  
**EPA:** Throttle: \_\_\_\_\_ % Brake: \_\_\_\_\_ %  
**ESC:** \_\_\_\_\_  
**ESC Settings:** \_\_\_\_\_  
**Motor:** \_\_\_\_\_ **Timing:** \_\_\_\_\_  
**Pinion:** \_\_\_\_\_ **Spur:** \_\_\_\_\_  
**Battery:** \_\_\_\_\_  
**Battery Position:** \_\_\_\_\_

**Front Diff Fluid:** \_\_\_\_\_  
**Center Diff Fluid:** \_\_\_\_\_  
**Rear Diff Fluid:** \_\_\_\_\_  
**Slipper Clutch:** \_\_\_\_\_  
**# of Pads:** \_\_\_\_\_

Notes

Shocks:	Front	Rear
<b>Piston:</b>		
<b>Fluid:</b>		
<b>Spring:</b>		
<b>Limiters:</b>		
<b>Stroke:</b>		
<b>Eyelet Length:</b>		
<b>Notes:</b>		



Track Info, Tires & Aero

**Size:** Small  Medium  Large  Extra Large   
**Surface:** Dirt  Carpet  Astroturf  Multi Surface   
**Traction:** Low  Medium  High  Very High   
**Moisture:** Dry  Damp  Wet   
**Condition:** Indoor  Outdoor  Dusty  Hard Packed   
 Bumpy  Grooved  Smooth  Loamy   
**Temperature:** Ambient: \_\_\_\_\_ Humidity: \_\_\_\_\_

**Front Tires:** \_\_\_\_\_  
**Front Compound:** \_\_\_\_\_  
**Front Insert:** \_\_\_\_\_  
**Rear Tires:** \_\_\_\_\_  
**Rear Compound:** \_\_\_\_\_  
**Rear Insert:** \_\_\_\_\_  
**Wheel (F/R):** \_\_\_\_\_

Notes

**Body:** \_\_\_\_\_  
**Wing:** \_\_\_\_\_  
**Total Vehicle Weight:** \_\_\_\_\_  
**Chassis Weights:** \_\_\_\_\_

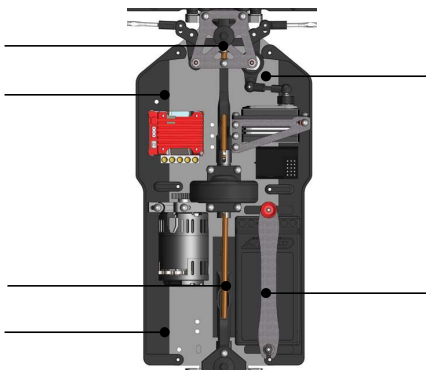

Comments

Notes