

# 4XS SETUP SHEET

SHORTY PACK

SADDLE PACK

DRIVER: \_\_\_\_\_ DATE: \_\_\_\_\_ AIR TEMP.: \_\_\_\_\_ HUMIDITY: \_\_\_\_\_ %

TRACK: \_\_\_\_\_ TRACK CONDITION: \_\_\_\_\_ TRACK TEMP.: \_\_\_\_\_

FRONT WIDTH: \_\_\_\_\_ REAR WIDTH: \_\_\_\_\_ WHEELBASE: \_\_\_\_\_ mm

MOTOR: \_\_\_\_\_ SPUR GEAR: \_\_\_\_\_ PINION GEAR: \_\_\_\_\_ BATTERY: \_\_\_\_\_

SERVO: \_\_\_\_\_ WING: \_\_\_\_\_ FRONT TIRE INSERT: \_\_\_\_\_

REAR TIRE INSERT: \_\_\_\_\_ FRONT ANTI ROLL BAR: \_\_\_\_\_ mm REAR ANTI ROLL BAR: \_\_\_\_\_ mm

BEST LAP: \_\_\_\_\_

## FRONT

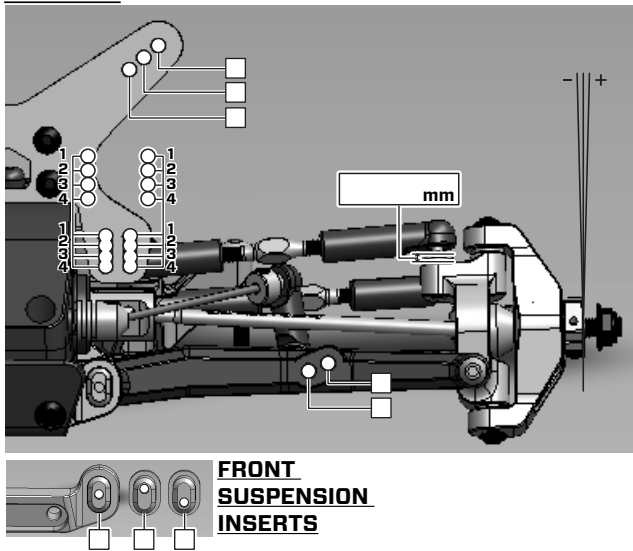

**CAMBER**

L \_\_\_\_\_

R \_\_\_\_\_

**FRONT TIRE**

\_\_\_\_\_

**HARDNESS**

\_\_\_\_\_

**FRONT DIFF.**

\_\_\_\_\_ wt.

**GEAR DIFF.**

**TOE ANGLE**

\_\_\_\_\_

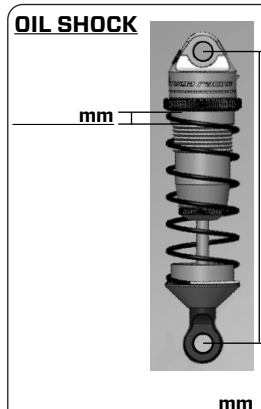

**OIL**

\_\_\_\_\_ wt.

**LIMITERS**

\_\_\_\_\_ mm

**PISTON**

\_\_\_\_\_

**SPRING**

\_\_\_\_\_

**RIDE HEIGHT**

\_\_\_\_\_ mm

**STEERING BALL STUD (INNER)**

\_\_\_\_\_ mm

## REAR

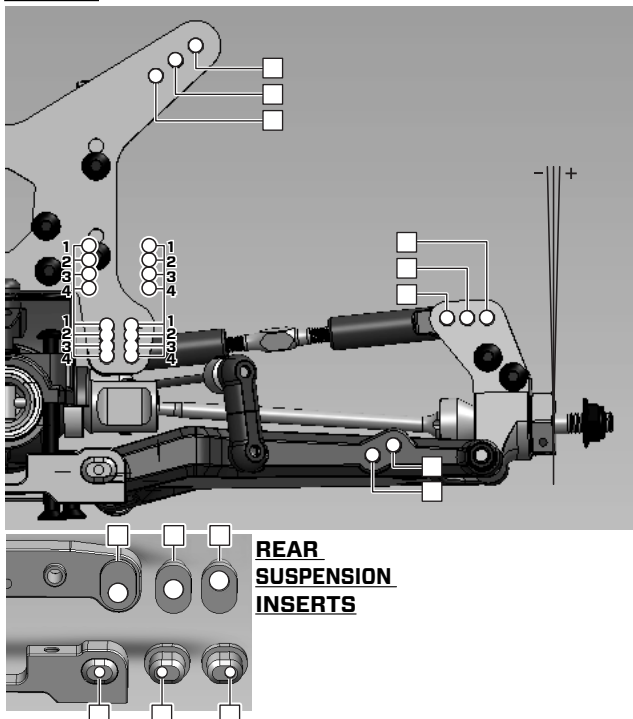

**CAMBER**

L \_\_\_\_\_

R \_\_\_\_\_

**REAR TIRE**

\_\_\_\_\_

**HARDNESS**

\_\_\_\_\_

**REAR DIFF.**

\_\_\_\_\_ wt.

**GEAR DIFF.**

**TOE ANGLE**

\_\_\_\_\_

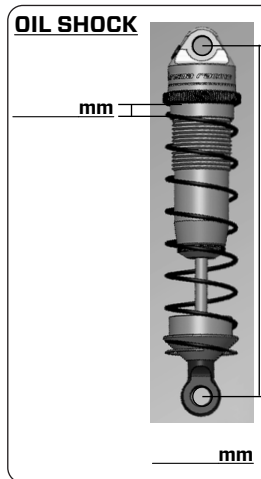

**OIL**

\_\_\_\_\_ wt.

**LIMITERS**

\_\_\_\_\_ mm

**PISTON**

\_\_\_\_\_

**SPRING**

\_\_\_\_\_

**RIDE HEIGHT**

\_\_\_\_\_ mm

## MID DIFF.

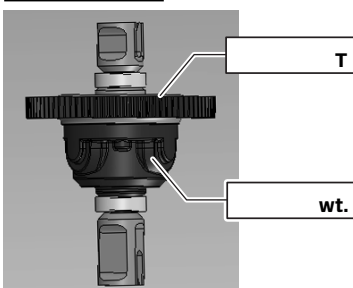

## MID SLIPPER

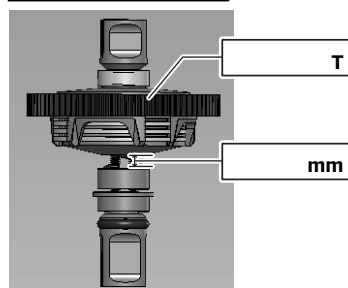

## REAR SUSPENSION SPACER

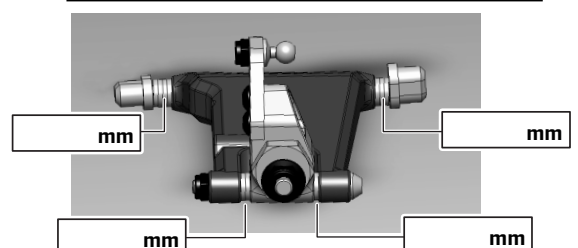

NOTES: \_\_\_\_\_