

Driver: _____ **Date:** _____ **Air Temp.:** _____ **Track Temp.:** _____ **Humidity:** _____
Track: _____ **Event** _____ Indoor Outdoor Open Tight
 Astroturf Clay Dirt Hard Packed Loose Carpet Grass Soft Dirt Other:
 Low Medium High Smooth Bumpy Dry Wet **Notes:** _____
Motor: _____ **ESC:** _____ **Servo** _____
Spur Gear: _____ **ESC Settings:** _____ **Receiver** _____
Pinion Gear: _____ **Battery:** _____ **Wing** _____

Front

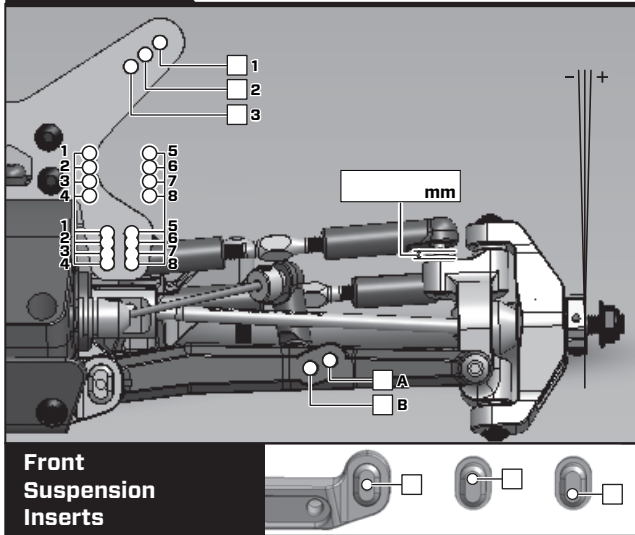

Camber:
L: _____ **R:** _____
Toe angle: _____
Front width: _____
Castor: _____
Ride Height: _____
Bumpsteer: _____
Anti-Roll Bar: _____
Front Diff Oil: _____

Front Tire	
Type	Insert
Notes	

Shock	
Notes	
	Oil: _____
	Piston: _____
	Spring: _____
	Preload: _____
	Limiters _____
	In: _____
	Out: _____

Rear

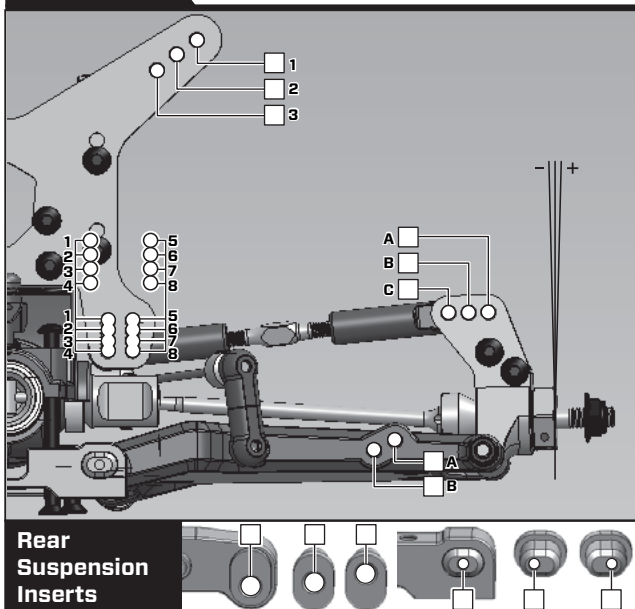

Camber:
L: _____ **R:** _____
Rear width: _____
Ride Height: _____
Anti-Roll Bar: _____
Rear Diff Oil: _____

REAR TIRE	
Type	Insert
Notes	

SHOCK	
Notes	
	Oil: _____
	Piston: _____
	Spring: _____
	Preload: _____
	Limiters _____
	In: _____
	Out: _____

Notes

