

Driver: _____ Date: _____ Air Temp.: _____ Track Temp.: _____ Humidity: _____

Track: _____ Event _____ Indoor Outdoor Open Tight

Astroturf Clay Dirt Hard Packed Loose Carpet Grass Soft Dirt Other: _____

Low Medium High Smooth Bumpy Dry Wet Notes: _____

Motor: _____ ESC: _____ Servo _____

Spur Gear: _____ ESC Settings: _____ Receiver _____

Pinion Gear: _____ Battery: _____ Wing _____

Front

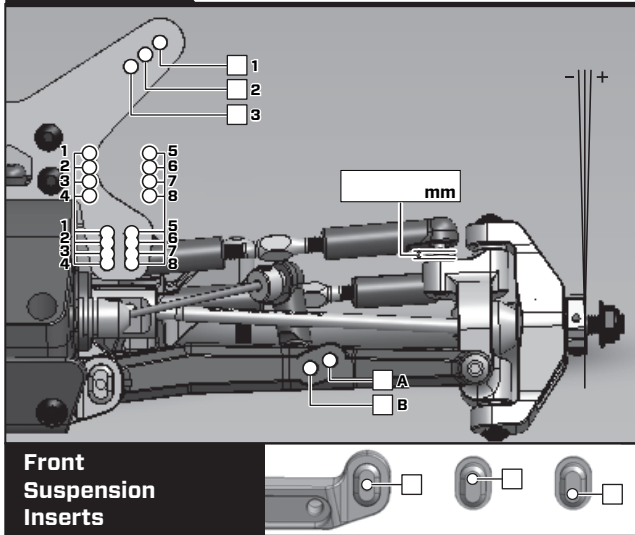

Camber:
L: _____ R: _____

Toe angle:

Front width:

Castor:

Ride Height:

Bumpsteer:

Anti-Roll Bar:

Front Diff Oil:

Front Tire	
Type	Insert
Notes	

Shock	
Notes	
	Oil: _____
	Piston: _____
	Spring: _____
	Preload: _____
	Limiters _____
	In: _____
	Out: _____

Rear

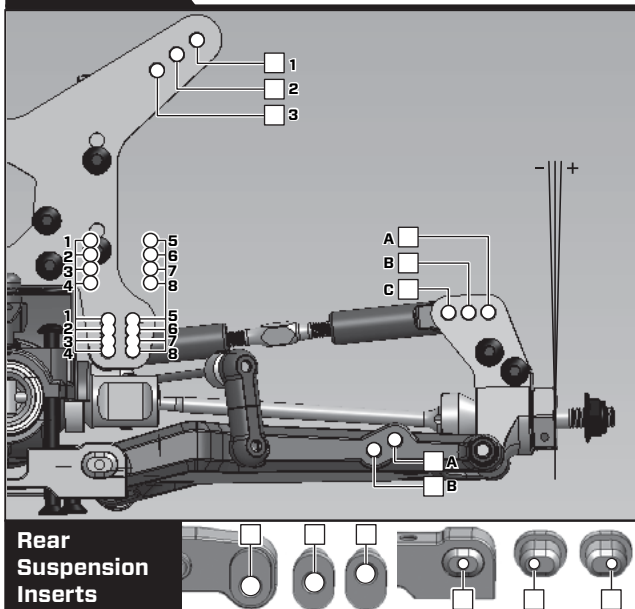

Camber:
L: _____ R: _____

Rear width:

Ride Height:

Anti-Roll Bar:

Rear Diff Oil:

REAR TIRE	
Type	Insert
Notes	

SHOCK	
Notes	
	Oil: _____
	Piston: _____
	Spring: _____
	Preload: _____
	Limiters _____
	In: _____
	Out: _____

Notes

