

Name: \_\_\_\_\_ Date: \_\_\_\_\_  
 Track: \_\_\_\_\_ Event: \_\_\_\_\_

Track Conditions  Indoor  Outdoor  Tight  Open  Smooth  Rough  Hard Packed  Loose/Loamy  Blue Groove  Dry  Wet  Dusty  Low Bite  Med Bite  High Bite  Other \_\_\_\_\_

## Front Suspension

Toe: \_\_\_\_\_  
 Ride Height: \_\_\_\_\_  
 Camber: \_\_\_\_\_  
 Caster: \_\_\_\_\_  
 Sway Bar: \_\_\_\_\_  
 Oil: \_\_\_\_\_  
 Piston: \_\_\_\_\_  
 Spring: \_\_\_\_\_  
 Limiters: \_\_\_\_\_  
 Spindle Height: \_\_\_\_\_  
 Axle Spacer: \_\_\_\_\_  
 Steering Type: \_\_\_\_\_  
 Bump Steer: \_\_\_\_\_  
 Camber Link: \_\_\_\_\_  
 Shock Location: \_\_\_\_\_  
 VLA: \_\_\_\_\_  
 Front Wing: \_\_\_\_\_

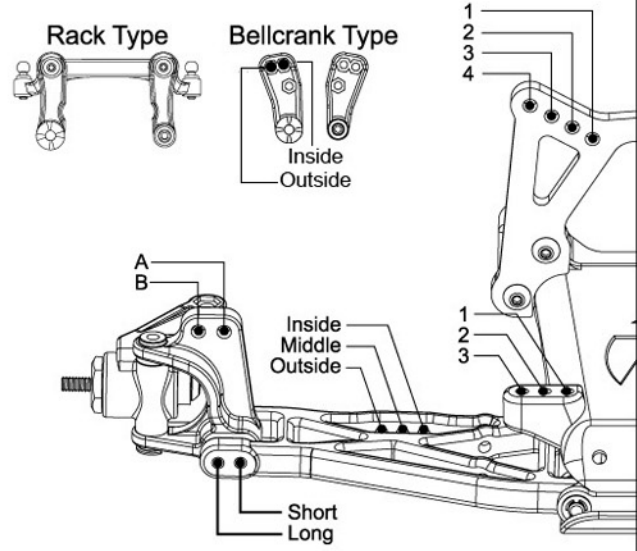

Notes: \_\_\_\_\_  
 \_\_\_\_\_  
 \_\_\_\_\_

## Rear Suspension

Toe: \_\_\_\_\_  
 Pivot Support: \_\_\_\_\_  
 Ride Height: \_\_\_\_\_  
 Camber: \_\_\_\_\_  
 Rear Hub Spacing: \_\_\_\_\_  
 Drive Shafts/Outdrives: \_\_\_\_\_  
 Sway Bar: \_\_\_\_\_  
 Oil: \_\_\_\_\_  
 Piston: \_\_\_\_\_  
 Spring: \_\_\_\_\_  
 Limiters: \_\_\_\_\_  
 Camber Link: \_\_\_\_\_  
 Shock Location: \_\_\_\_\_  
 VLA: \_\_\_\_\_  
 Wing Position/Mount: \_\_\_\_\_  
 Body & Wing Type: \_\_\_\_\_  
 Battery Position: \_\_\_\_\_

- LHD
- RHD

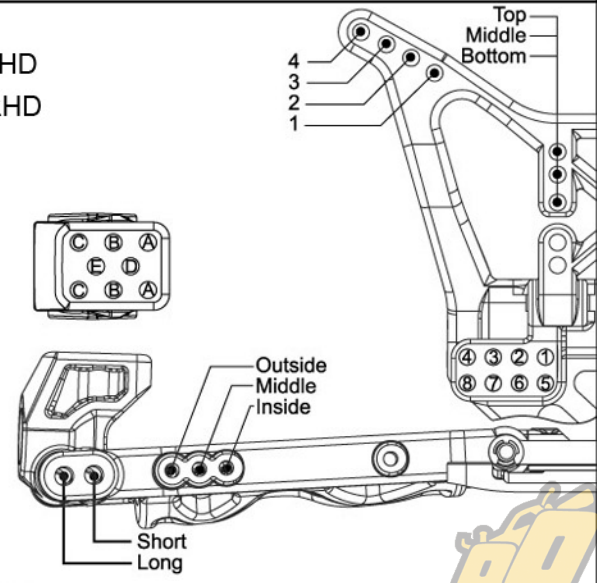

Notes: \_\_\_\_\_  
 \_\_\_\_\_  
 \_\_\_\_\_

Weight Placement (Mark with "X")

Weight of each piece \_\_\_\_\_ oz.

Tires:	Type	Compound	Insert	Additive	Motor:
Front:	_____	_____	_____	_____	_____
Rear:	_____	_____	_____	_____	_____
Notes:	_____				Pinon: _____
	_____				ESC: _____
	_____				Reverse rotor <input type="checkbox"/>