

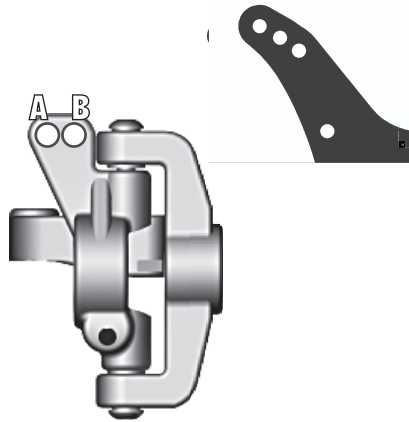

:: Driver: _____ :: Date: _____
 :: Track: _____
 :: Event: _____

:: Front Suspension

anti-roll bar:
 .047" - black
 .055" - silver



bumpsteer: _____
 camber: _____ °
 toe: _____ °
 ride height: _____ mm

washers: _____



notes: _____

:: Rear Suspension

anti-roll bar:
 .047" - black
 .055" - silver

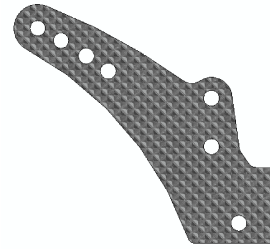

camber: _____ °
 toe: _____ °
 ride height: _____ mm

wheelbase:
 long
 medium
 short

anti-squat washers: _____



washers: _____



notes: _____

:: Front Shocks

spring: _____ piston: _____
 shock fluid: _____ limiters: _____

:: Rear Shocks

spring: _____ piston: _____
 shock fluid: _____ limiters: _____

:: Differentials

front setting: _____
 rear setting: _____

:: Wing

type: _____
 angle: 3° 6° 9°

:: Electronics

motor: _____
 gearing: ____/____
 esc: _____ setting: _____

:: Front Tires

tire: _____
 compound: _____
 insert: _____
 wheel: _____

:: Rear Tires

tire: _____
 compound: _____
 insert: _____
 wheel: _____

:: Race and Vehicle Comments

qualify: _____ main: _____ finish: _____ tq:
 comments: _____

:: Track Info

smooth: bumpy: blue groove:
 traction: high med. low
 soft dirt: grass: clay: wet:
 dusty: other: _____

