

**Front Suspensions:**

Camber: \_\_\_\_\_ °  
 Total Toe: \_\_\_\_\_ °  
 Ride Height: \_\_\_\_\_  
 Arm Type: \_\_\_\_\_  
 Tower Type: \_\_\_\_\_  
 Caster Block Insert: \_\_\_\_\_ °  
 Kick-Up Angle: \_\_\_\_\_ °  
 Wheel Hex: \_\_\_\_\_

Notes: \_\_\_\_\_  
 \_\_\_\_\_  
 \_\_\_\_\_  
 \_\_\_\_\_

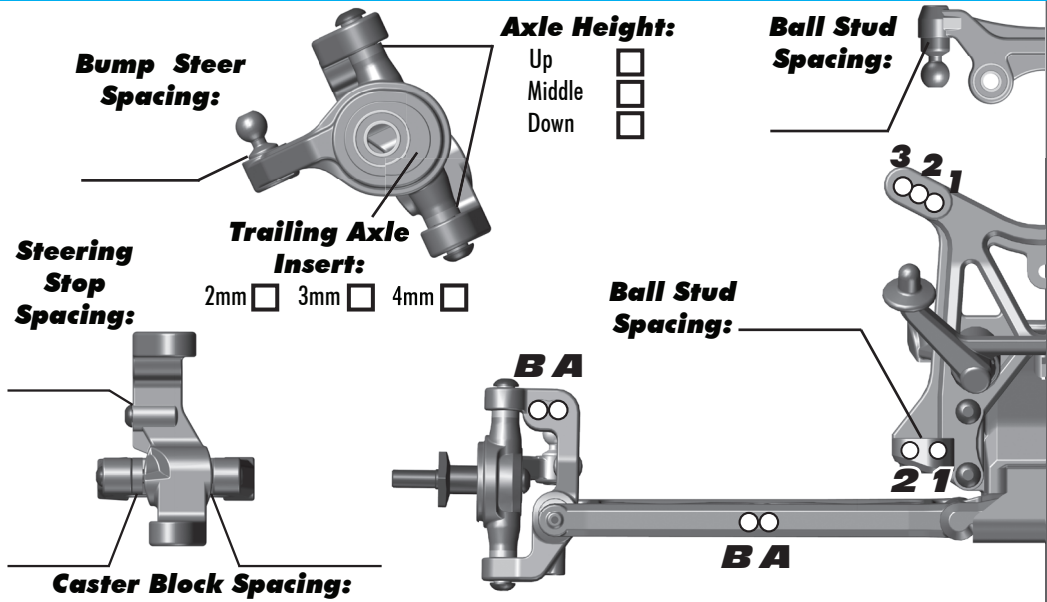

**Rear Suspension:**

Camber: \_\_\_\_\_ °  
 Ride Height: \_\_\_\_\_  
 Wheel Hex: \_\_\_\_\_  
 Hub Spacing: Forward  Middle  Back

Notes: \_\_\_\_\_  
 \_\_\_\_\_  
 \_\_\_\_\_  
 \_\_\_\_\_

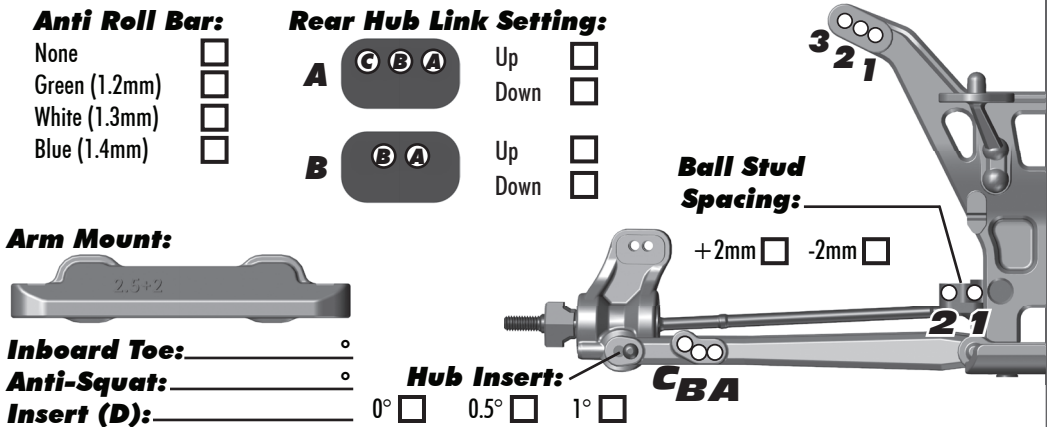

**Electronics:**

Radio: \_\_\_\_\_ Servo: \_\_\_\_\_  
 EPA: Throttle: \_\_\_\_\_ % Brake: \_\_\_\_\_ %  
 ESC: \_\_\_\_\_  
 ESC Settings: \_\_\_\_\_  
 Motor: \_\_\_\_\_  
 Wind: \_\_\_\_\_ Timing: \_\_\_\_\_  
 Pinion: \_\_\_\_\_ Spur: \_\_\_\_\_  
 Battery: \_\_\_\_\_  
 Battery Position: \_\_\_\_\_

**Drivetrain:**

**Differential:** 3 Gear:  4 Gear:   
 Ball Diff:  Gear Diff:   
 Notes: \_\_\_\_\_

**Slipper Clutch:** Type: \_\_\_\_\_  
 # of Pads: \_\_\_\_\_  
 Notes: \_\_\_\_\_

**Shocks:**

	Front	Rear
Piston:		
Oil:		
Spring:		
Limiters:		
Cup Offset:		
Stroke:		
Free Length:		
Notes:		

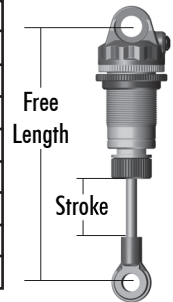

**Track Info:**

**Size:** Small  Medium  Large  Extra Large   
**Surfaces:** Dirt  Carpet  Astroturf  Multi Surface   
**Traction:** Low  Medium  High  Very High   
**Moisture:** Dry  Damp  Wet   
**Condition:** Indoor  Outdoor  Dusty  Hard Packed   
 Bumpy  Grooved  Smooth  Loamy

Temperature: Ambient: \_\_\_\_\_ Track: \_\_\_\_\_  
 Notes: \_\_\_\_\_

**Tires:**

Tires (F/R): \_\_\_\_\_ / \_\_\_\_\_  
 Compound (F/R): \_\_\_\_\_ / \_\_\_\_\_  
 Insert (F/R): \_\_\_\_\_ / \_\_\_\_\_  
 Wheel (F/R): \_\_\_\_\_ / \_\_\_\_\_  
 Notes: \_\_\_\_\_

**Body & Wing:**

Body: \_\_\_\_\_  
 Wing: \_\_\_\_\_  
 Notes: \_\_\_\_\_

**Race Results:**

Qualify: \_\_\_\_\_ Main: \_\_\_\_\_  
 Finish: \_\_\_\_\_ TQ:   
 Best Lap Time: \_\_\_\_\_

**Vehicle Comments:**

\_\_\_\_\_  
 \_\_\_\_\_  
 \_\_\_\_\_  
 Total Vehicle Weight: \_\_\_\_\_