

SETUP SHEET for the Team Associated RC10T4

Driver _____

Track / City _____

Event _____ Date _____

FRONT

SHOCK MOUNTING & CAMBER LINK

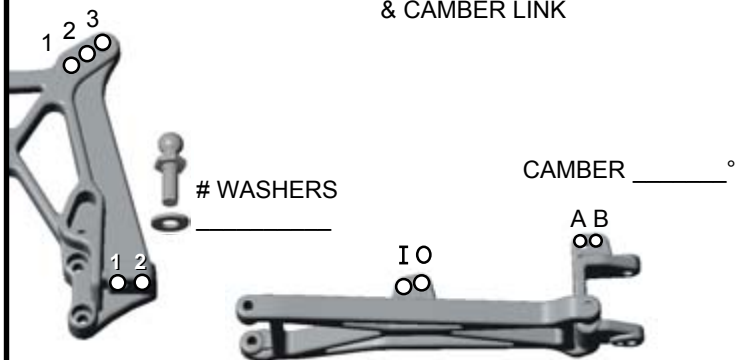

RIDE HEIGHT _____

TOE-IN (+) / OUT (-) _____°

BUMP STEER SPACER _____

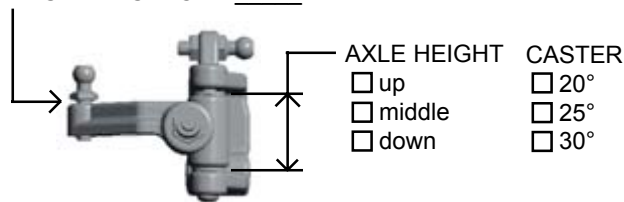

STEERING BLOCK trailing inline

FRONT SHOCKS

OIL _____ wt

SPRING (color) _____ PISTON # _____

SHAFT unobtainium STD # LIMITERS _____

FRONT TIRES & WHEELS

FRONT TIRES _____

INSERTS _____ WHEELS _____

TRACTION COMPOUND _____

REAR

SHOCK MOUNTING & CAMBER LINK

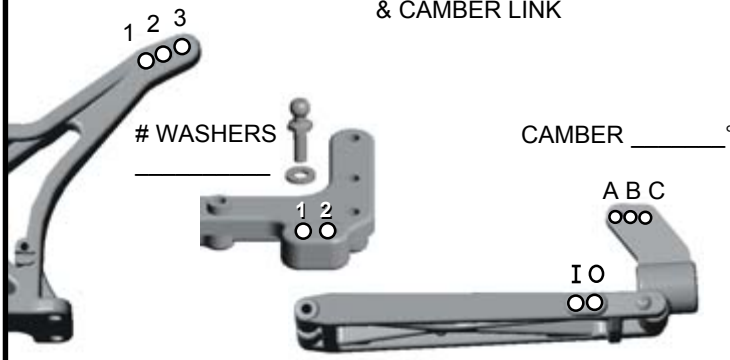

RIDE HEIGHT _____

ANTI-SQUAT

- 0°
- 1°
- 2°
- 3°

WHEELBASE

- long
- medium
- short

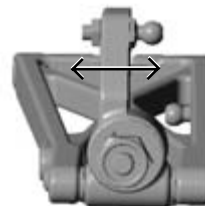

ANTI-ROLL BAR

- none
- black (soft)
- silver (med)
- gold (heavy)

REAR SHOCKS

OIL _____ wt

SPRING (color) _____ PISTON # _____

SHAFT unobtainium STD # LIMITERS _____

REAR TIRES & WHEELS

REAR TIRES _____

INSERTS _____ WHEELS _____

RADIO/BATTERIES

RADIO _____ SERVO _____

ESC _____

DRAG BRAKE _____ INIT BRAKE _____

BATTERIES _____

BATTERY PLACEMENT: spacers in front _____ spacers in rear _____

MOTOR

MOTOR & WIND _____

BRUSHES _____

SPRING _____

PINION / SPUR _____ / _____

OTHER

BODY _____

SPOILER _____

CHASSIS _____

CONDITIONS

- smooth
- bumpy
- low traction
- med traction
- high traction
- sandy
- soft dirt
- grass
- blue groove
- clay
- wet
- dry
- dusty
- other

COMMENTS