

SETUP SHEET

TEAM ASSOCIATED

RC10T3

driver MARK SMITH

track / city B & L HOBBIES & RACEWAY, FARMINGTON, MO

event _____ date 9-9-98

FRONT SUSPENSION

- ① CASTER 25° 30°
- ② FRONT RIDE HEIGHT ARMS LEVEL other _____
- ③ CAMBER 1.5°
- ④ ANTI ROLL BAR NONE
 THICK
 THIN
 other _____
- ⑤ TOE-IN 0° TOE-OUT 0°
- ⑥ BUMP STEER SPACERS _____
- ⑦ STEERING ACKERMAN STD
 OPTIONAL

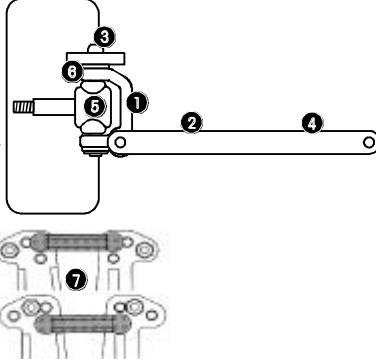

FRONT SHOCKS

- BODY STD GRAY other _____
- BODY 1.02 other _____
- SHAFT 1.02 other _____
- SHAFT STD Unobtainium

LIMITERS, inside _____
LIMITERS, outside _____

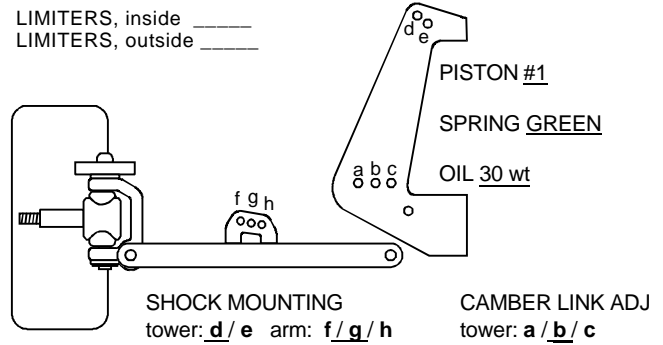

REAR SUSPENSION

- ① CAMBER _____°
- ② REAR RIDE HEIGHT BONES LEVEL other _____
 MIP CVD's DOGBONES UNIVERSALS
- ③ TOE-IN / ANTI-SQUAT 2-3 3-3 3-0 mount
- ④ ANTI ROLL BAR NONE
 THICK
 THIN
 other _____

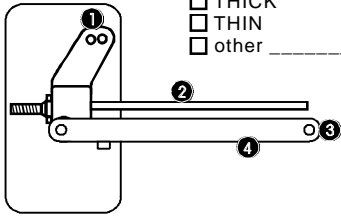

WHEELBASE ADJUSTMENT

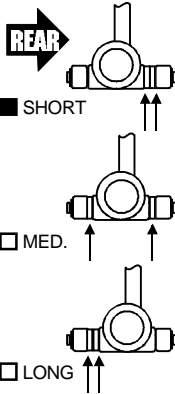

REAR SHOCKS

- BODY STD GRAY other _____
- BODY 1.39 other _____
- SHAFT 1.32 other _____
- SHAFT STD Unobtainium

LIMITERS, in _____
LIMITERS, out _____

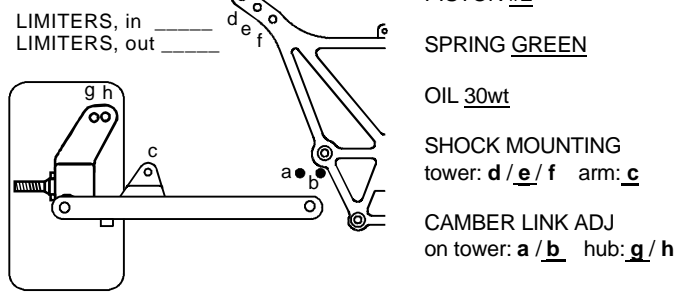

OTHER

WEIGHT IN BULKHEAD _____
BODY _____ SPOILER

FRONT TIRES M3 FOAM YES

REAR TIRES M3 FUZZIE FOAM YES

FRONT WHEELS 1 PC. 3 PC. other _____
REAR WHEELS 1 PC. 3 PC. other _____

CHASSIS STD SHORT LONG GRAPHITE

MOTOR TYPE H.O. PINION 20T SPUR 87T
BRUSHES _____ SPRING _____

NOTES _____

SLIPPER ASSOC. HYDRA VISCOUS

BATTERIES _____ PLACEMENT FRONT MIDDLE REAR

RADIO FUTABA SERVO 158 AIR SPD. CONT. CYCLONE

TRACK CONDITIONS

SURFACE smooth bumpy BUMPS: _____

TRACTION low med. high

COMPOSITION

sandy soft dirt grass clay other _____
 wet dry dusty other _____

other: _____

RACE COMMENTS

MAIN _____ PLACE _____ TQ

1ST PLACE - STOCK TRUCK

1ST PLACE - MASTERS, TQ MASTERS

TRUCK COMMENTS

T3 WORKED GREAT ALL WEEKEND! AS USUAL!