

Driver: _____ Date: _____

Track: _____ Event: _____

Front Suspension:

Camber: _____ °
 Total Toe: _____ °
 Ride Height: _____
 Arm Type: _____
 Tower Type: _____
 Caster Block Insert: _____ °
 Kick-Up Angle: _____ °
 Wheel Hex: _____

Notes: _____

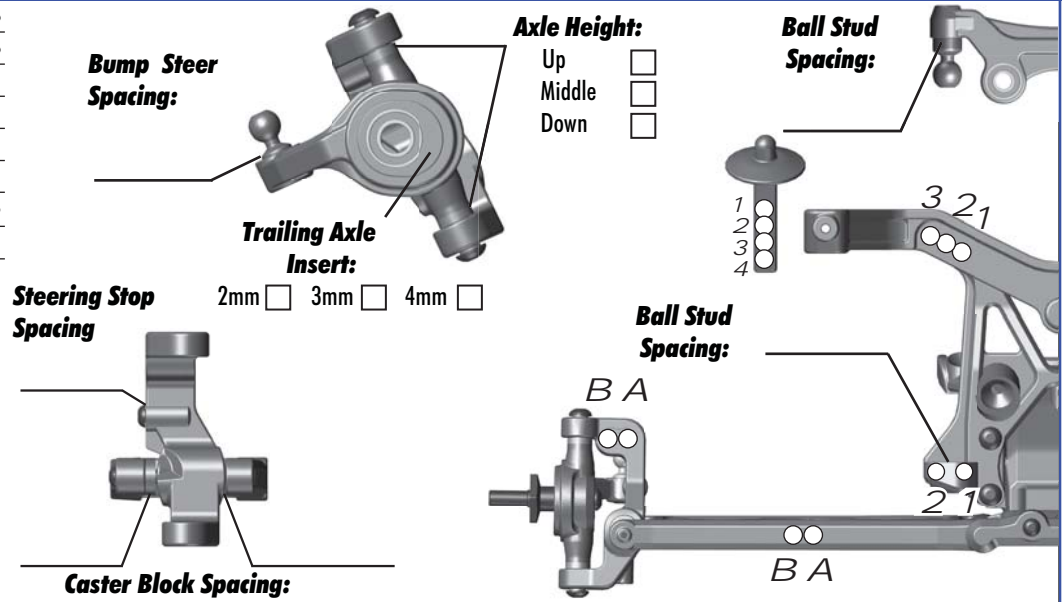

Rear Suspension:

Camber: _____ °
 Ride Height: _____
 Wheel Hex: _____
 Hub Spacing:
 Forward Middle Back

Notes: _____

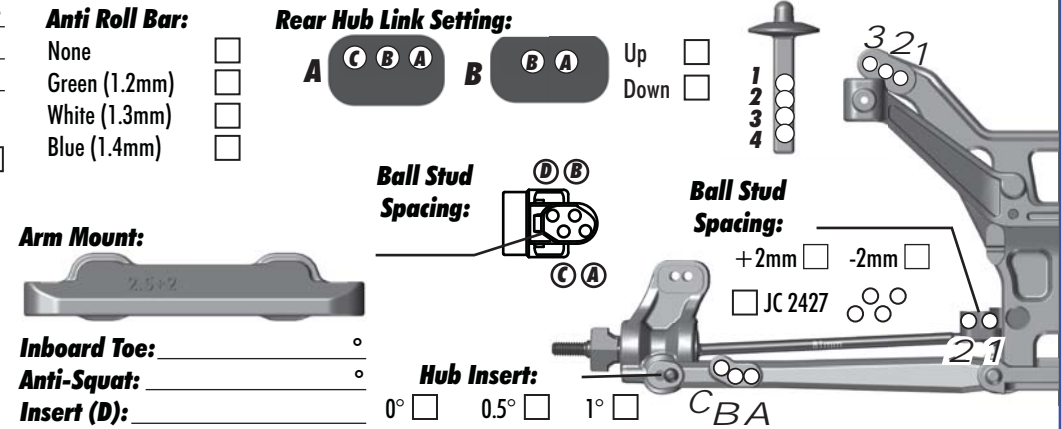

Electronics:

Radio: _____ Servo: _____
 EPA: Throttle: _____ % Brake: _____ %
 ESC: _____
 ESC Settings: _____
 Motor: _____
 Wind: _____ Timing: _____
 Pinion: _____ Spur: _____
 Battery: _____
 Battery Position: _____

Drivetrain:

Differential:
 3 Gear: 4 Gear:
 Ball Diff: Gear Diff:
 Notes: _____

Slipper Clutch:
 Type: _____
 # of Pads: _____
 Notes: _____

Shocks:

	Front	Rear
Piston:		
Oil:		
Spring:		
Limiters:		
Cup Offset:		
Stroke:		
Free Length:		
Notes:		

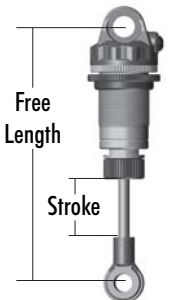

Track Info:

Size: Small Medium Large Extra Large
Surfaces: Dirt Carpet Astroturf Multi Surface
Traction: Low Medium High Very High
Moisture: Dry Damp Wet
Condition: Indoor Outdoor Dusty Hard Packed
 Bumpy Grooved Smooth Loamy

Tires:

Tires (F/R): _____ / _____
Compound (F/R): _____ / _____
Insert (F/R): _____ / _____
Wheel (F/R): _____ / _____
 Notes: _____

Body & Wing:

Body: _____
Wing: _____
 Notes: _____

Temperature: Ambient: _____ Track: _____
 Notes: _____

Race Results:

Quality: _____ **Main:** _____
Finish: _____ **TQ:**
Best Lap Time: _____

Vehicle Comments:

Total Vehicle Weight: _____