

Driver: \_\_\_\_\_ Date: \_\_\_\_\_

Track: \_\_\_\_\_ Event: \_\_\_\_\_

### Front Suspension:

Camber: \_\_\_\_\_ °  
 Total Toe: \_\_\_\_\_ °  
 Ride Height: \_\_\_\_\_  
 Arm Type: \_\_\_\_\_  
 Tower Type: \_\_\_\_\_  
 Caster Block Insert: \_\_\_\_\_ °  
 Kick-Up Angle: \_\_\_\_\_ °  
 Wheel Hex: \_\_\_\_\_

Notes: \_\_\_\_\_

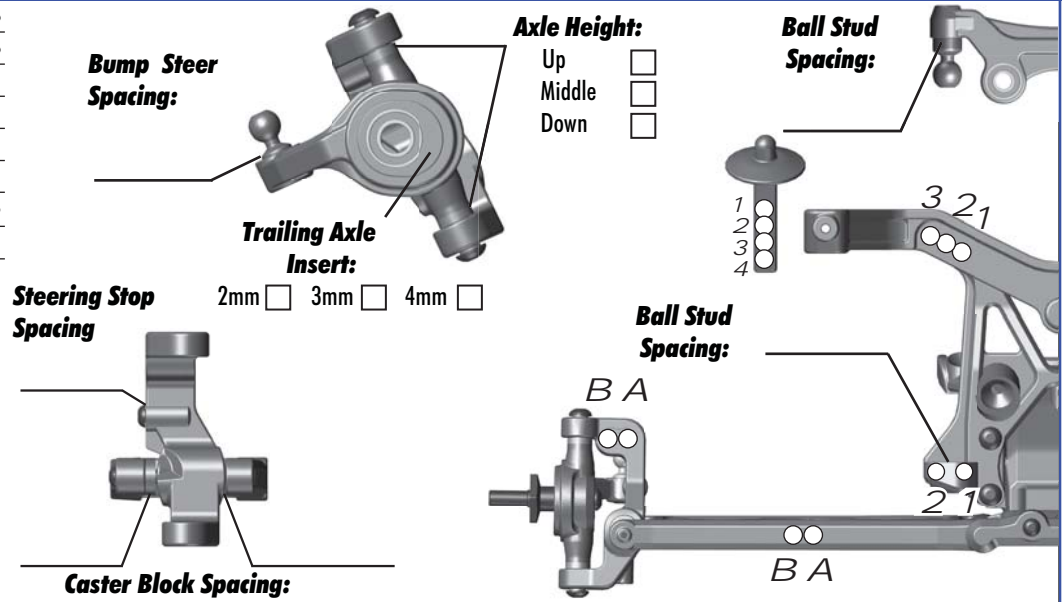

### Rear Suspension:

Camber: \_\_\_\_\_ °  
 Ride Height: \_\_\_\_\_  
 Wheel Hex: \_\_\_\_\_  
 Hub Spacing: \_\_\_\_\_

Forward  Middle  Back

Notes: \_\_\_\_\_

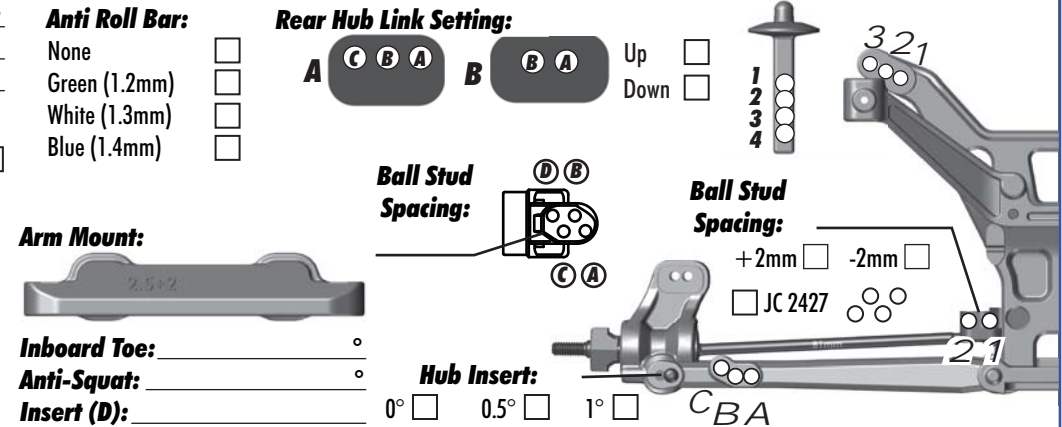

### Electronics:

Radio: \_\_\_\_\_ Servo: \_\_\_\_\_  
 EPA: Throttle: \_\_\_\_\_ % Brake: \_\_\_\_\_ %  
 ESC: \_\_\_\_\_  
 ESC Settings: \_\_\_\_\_  
 Motor: \_\_\_\_\_  
 Wind: \_\_\_\_\_ Timing: \_\_\_\_\_  
 Pinion: \_\_\_\_\_ Spur: \_\_\_\_\_  
 Battery: \_\_\_\_\_  
 Battery Position: \_\_\_\_\_

### Drivetrain:

**Differential:**  
 3 Gear:  4 Gear:   
 Ball Diff:  Gear Diff:   
 Notes: \_\_\_\_\_

**Slipper Clutch:**  
 Type: \_\_\_\_\_  
 # of Pads: \_\_\_\_\_  
 Notes: \_\_\_\_\_

### Shocks:

	Front	Rear
Piston:		
Oil:		
Spring:		
Limiters:		
Cup Offset:		
Stroke:		
Free Length:		
Notes:		

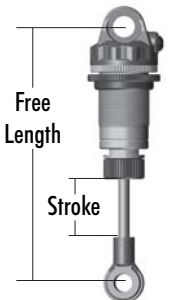

### Track Info:

**Size:** Small  Medium  Large  Extra Large   
**Surfaces:** Dirt  Carpet  Astroturf  Multi Surface   
**Traction:** Low  Medium  High  Very High   
**Moisture:** Dry  Damp  Wet   
**Condition:** Indoor  Outdoor  Dusty  Hard Packed   
 Bumpy  Grooved  Smooth  Loamy

Temperature: Ambient: \_\_\_\_\_ Track: \_\_\_\_\_  
 Notes: \_\_\_\_\_

### Tires:

Tires (F/R): \_\_\_\_\_ / \_\_\_\_\_  
 Compound (F/R): \_\_\_\_\_ / \_\_\_\_\_  
 Insert (F/R): \_\_\_\_\_ / \_\_\_\_\_  
 Wheel (F/R): \_\_\_\_\_ / \_\_\_\_\_  
 Notes: \_\_\_\_\_

### Body & Wing:

Body: \_\_\_\_\_  
 Wing: \_\_\_\_\_  
 Notes: \_\_\_\_\_

### Race Results:

Quality: \_\_\_\_\_ Main: \_\_\_\_\_  
 Finish: \_\_\_\_\_ TQ:   
 Best Lap Time: \_\_\_\_\_

### Vehicle Comments:

Total Vehicle Weight: \_\_\_\_\_