

Front Suspension

Anti Roll Bar:

- 2.2mm Green
- 2.3mm White
- 2.4mm Blue
- 2.5mm Yellow

Steering System:

- Swing Rack
- Bellcrank Rack

Bumpsteer Washers: _____

Camber: _____

Caster: _____

Toe: _____

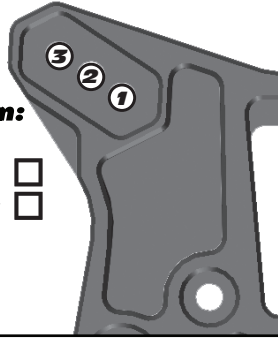

Upper Hinge Pin Bushing

Front # _____
Up Down

Rear # _____
Up Down

B-Plate Type

Low Original

Kickup Bushing A-Plate

Up Down

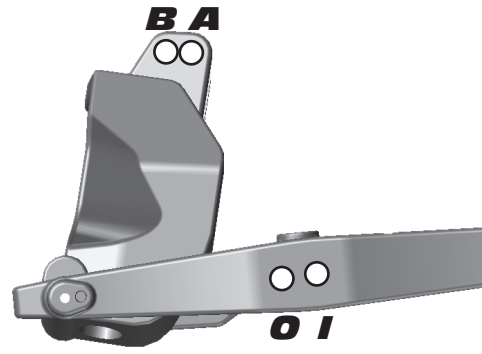

Ride Height: _____

Rear Suspension

Anti Roll Bar:

- 2.5mm Green
- 2.6mm White
- 2.7mm Blue
- 2.8mm Yellow

Wheelbase:

- Long
- Medium
- Short

Camber: _____

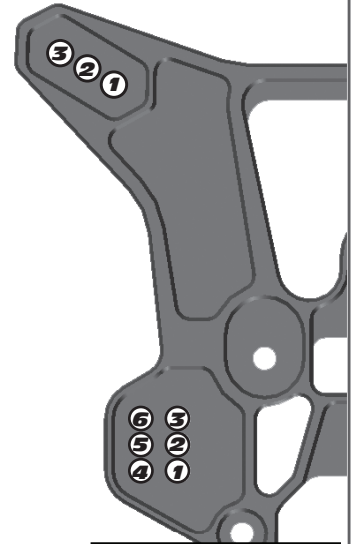

Toe Bushing D-Plate

In Out

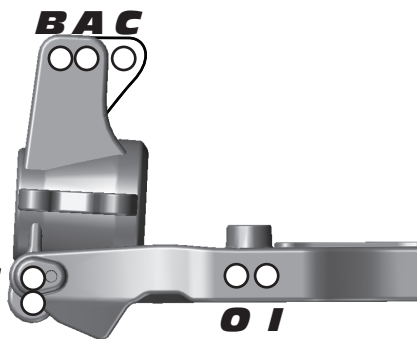

Hub: Upper Lower

Squat Bushing C-Plate

Up Down

Ride Height: _____

Front Shocks

Spring: _____ Shock Cap: _____
Shock Fluid: _____ Length: _____
Piston: _____ Rebound: _____

Rear Shocks

Spring: _____ Shock Cap: _____
Shock Fluid: _____ Length: _____
Piston: _____ Rebound: _____

Chassis Braces / Wheel Hex

Chassis Braces: Wheel Hex:
Pivot Standard
Molded Narrow
Aluminum

Chassis Weight

Weight: _____

Rear Hubs

Rear Hubs:
Standard
CNC FT Alum.

Differentials

Front Diff Fluid: _____
Center Diff Fluid: _____
Rear Diff Fluid: _____
Notes: _____

Body / Wing

Body Type: _____
Wing Type: _____
Gap to Tower (MM): _____

Gearing

Spur Gear: _____
Pinion: _____

Motor / ESC / Batteries

Motor & Wind: _____
ESC: _____
ESC Setting: _____
Batteries: _____

Tires

Tire (F/R): _____ / _____
Compound (F/R): _____ / _____
Inserts (F/R): _____ / _____
Wheel (F/R): _____ / _____
Notes: _____

Radio / Servos

Radio: _____
Steering Servo: _____ Steering Expo: _____
Brake Expo: _____
Initial Brake: _____ Drag Brake: _____
Dual Rate: _____

Race and Vehicle Comments

Qualify: _____ Main: _____ Finish: _____ TQ: _____
Comments: _____

Track Info

Traction: High Medium Low
Surface: Smooth Bumpy Blue Groove
Soft Dirt Grass Clay Wet
Astroturf Dusty Other: _____