

Front Suspension
Anti Roll Bar:

- 2.2mm Green
- 2.3mm White
- 2.4mm Blue
- 2.5mm Yellow

Steering System:

- Swing Rack
- Bellcrank Rack

Bumpsteer Washers: _____

Camber: _____

Caster: _____

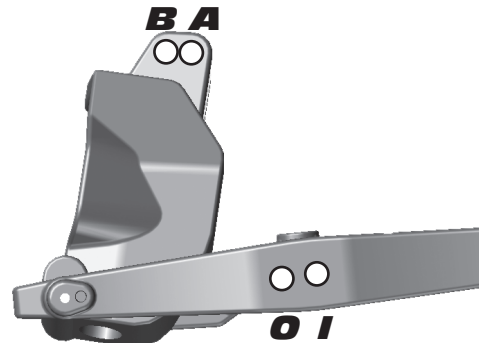
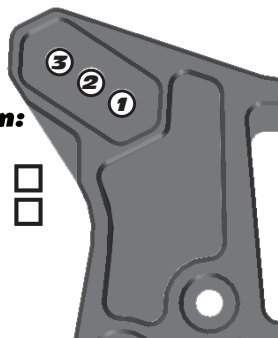
Toe: _____

Ride Height: _____

Upper Hinge Pin Bushing
Front # _____
 Up Down
Rear # _____
 Up Down
B-Plate Type

 Low Original
Kickup Bushing A-Plate
_____
 Up Down
Rear Suspension
Anti Roll Bar:

- 2.5mm Green
- 2.6mm White
- 2.7mm Blue
- 2.8mm Yellow

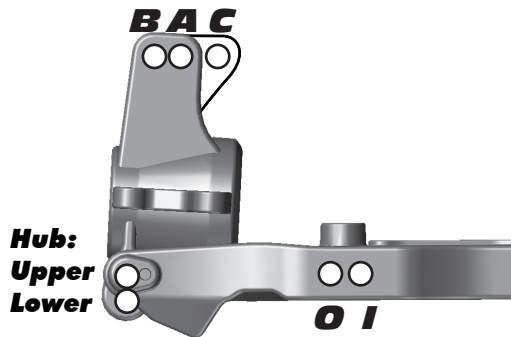
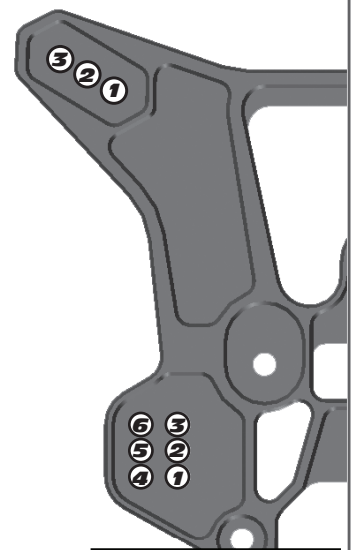
Wheelbase:

- Long
- Medium
- Short

Camber: _____

Ride Height: _____

Toe Bushing D-Plate
_____
 In Out
Squat Bushing C-Plate
_____
 Up Down
Front Shocks
Spring: _____ **Shock Cap:** _____
Shock Fluid: _____ **Length:** _____
Piston: _____ **Rebound:** _____

Rear Shocks
Spring: _____ **Shock Cap:** _____
Shock Fluid: _____ **Length:** _____
Piston: _____ **Rebound:** _____

Chassis Braces / Wheel Hex
Chassis Braces: **Wheel Hex:**
Pivot **Standard**
Molded **Narrow**
Aluminum
Chassis Weight
Weight: _____

Rear Hubs
Rear Hubs:
Standard
CNC FT Alum.
Differentials
Front Diff Fluid: _____
Center Diff Fluid: _____
Rear Diff Fluid: _____
Notes: _____

Body / Wing
Body Type: _____
Wing Type: _____
Gap to Tower (MM): _____

Gearing
Spur Gear: _____
Pinion: _____

Motor / ESC / Batteries
Motor & Wind: _____
ESC: _____
ESC Setting: _____
Batteries: _____

Tires
Tire (F/R): _____ / _____
Compound (F/R): _____ / _____
Inserts (F/R): _____ / _____
Wheel (F/R): _____ / _____
Notes: _____

Radio / Servos
Radio: _____
Steering Servo: _____ **Steering Expo:** _____
Brake Expo: _____
Initial Brake: _____ **Drag Brake:** _____
Dual Rate: _____

Race and Vehicle Comments
Qualify: _____ **Main:** _____ **Finish:** _____ **TQ:** _____
Comments: _____

Track Info
Traction: **High** **Medium** **Low**
Surface: **Smooth** **Bumpy** **Blue Groove**
Soft Dirt **Grass** **Clay** **Wet**
Astroturf **Dusty** **Other:** _____