

:: Front Suspension

anti-roll bar:
 2.2 - black
 2.5 - silver
 2.8 - gold

kickup bushing
 # _____
 up down

steering rack:
 back
 mid
 front

hinge pin bushing
 # _____
 up down

camber: _____
 caster: _____
 toe: _____
 ride height: _____ mm

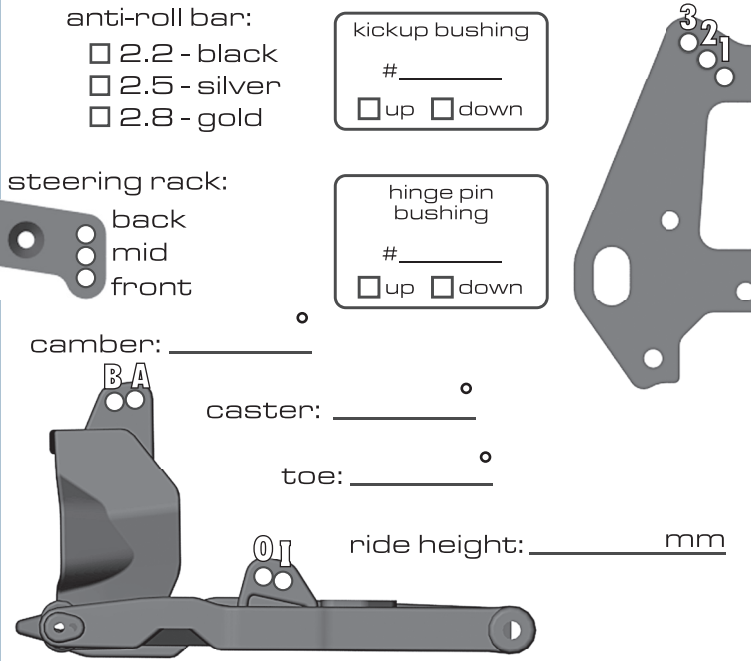

:: Rear Suspension

anti-roll bar:
 2.2 - black
 2.5 - silver
 2.8 - gold

anti-squat bushing
 # _____
 up down

wheelbase:
 long
 medium
 short

camber: _____
 toe: _____
 ride height: _____ mm

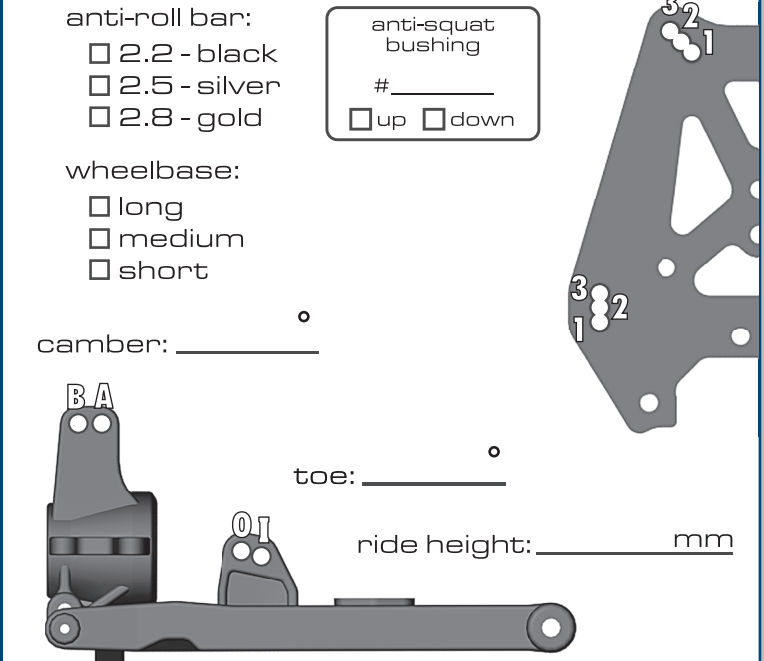

:: Front Shocks

spring: _____ piston: _____
 shock fluid: _____ length: _____

:: Rear Shocks

spring: _____ piston: _____
 shock fluid: _____ length: _____

:: Differentials

front fluid: _____
 center fluid: _____
 rear fluid: _____

:: Wing

location: forward back
 angle: low med. high
 type: _____

:: Notes

:: Engine

engine: _____ restrictor: _____
 muffler: _____ temp: _____
 glow plug: _____
 fuel: _____

:: Gearing/Clutch

gearing: _____
 clutch shoes: _____
 clutch spring: .9mm 1.0mm 1.1mm
 other: _____

:: Front Tires

tire: _____
 compound: _____
 insert: _____
 wheel: _____

:: Rear Tires

tire: _____
 compound: _____
 insert: _____
 wheel: _____

:: Race and Vehicle Comments

qualify: _____ main: _____ finish: _____ tq:
 comments: _____

:: Track Info

smooth: bumpy: blue groove:
 traction: high med. low
 soft dirt: grass: clay: wet:
 dusty: other: _____

