

TEAM ASSOCIATED RC10 SETUP SHEET

Driver: _____ Date: _____
 Track: _____ Event: _____
 Conditions: Indoor Outdoor Temp. _____ Rev. 1

Ride Height / Wheelbase

Front
Ride
Height:

Rear
Ride
Height:

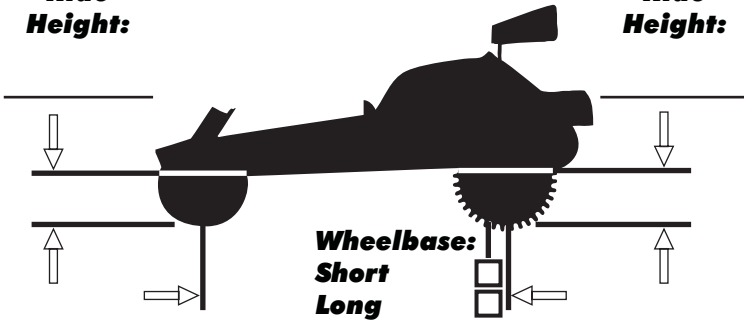

Rear Suspension

Camber: _____

Rear Hub
Carriers:
0°
1.5°

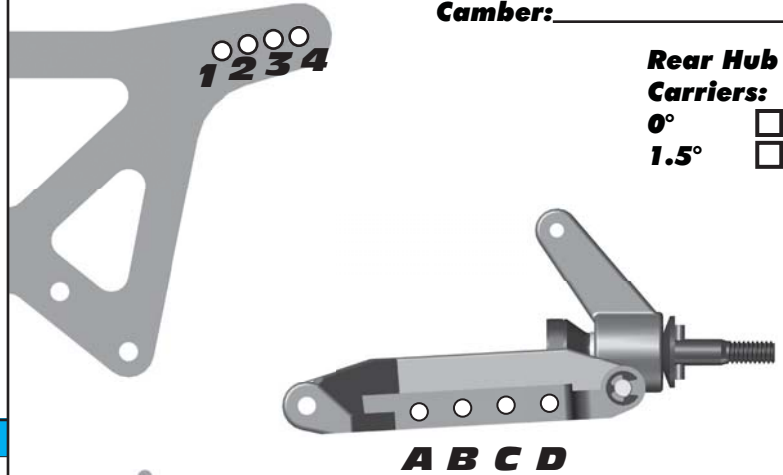

Front Suspension

Camber: _____

Toe: _____

Steering Block:
Inline
Trailing

Casters:
15°
30°

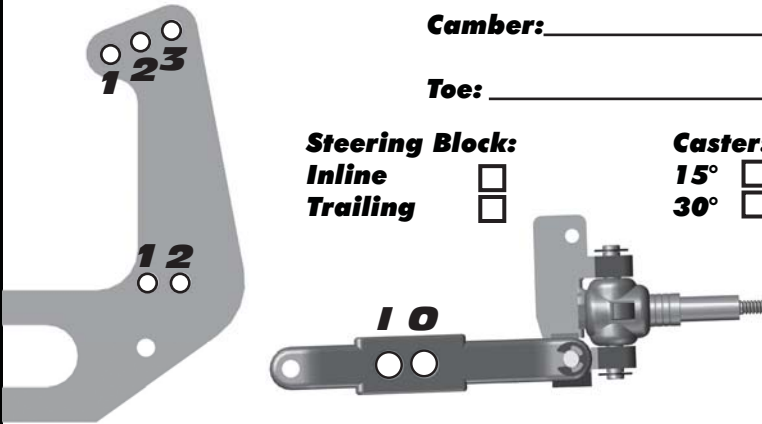

Rear Drive Shafts:
CVA
Dogbone

Front Shocks

Spring: _____ Piston: _____
 Shock Oil: _____ Limiter: _____

Rear Shocks

Spring: _____ Piston: _____
 Shock Oil: _____ Limiter: _____

Electronics

Motor & Wind: _____
 Pinion: _____ Spur Gear: _____
 Batteries: _____

Radio / ESC Settings

Radio: _____
 Throttle / Brake e.p.a.: _____
 Throttle / Brake expo: _____
 Servo: _____ Steering Expo: _____
 ESC: _____
 ESC Settings: _____

Drivetrain

Slipper: _____
 2 Pads 3 Pads 4 Pads
 Notes: _____

Other

Body Type: _____
 Wing Type: _____

Weight

Battery Placement: _____
 Ballast Weight: _____
 Notes: _____

Rear Tires

Tire: _____
 Compound: _____
 Insert: _____ Wheel: _____

Front Tires

Tire: _____
 Compound: _____
 Insert: _____ Wheel: _____

Track Info

Surface:	Traction:	Conditions:	Moisture:
Dirt <input type="checkbox"/>	Low <input type="checkbox"/>	Grooved <input type="checkbox"/>	Wet <input type="checkbox"/>
Carpet <input type="checkbox"/>	Med <input type="checkbox"/>	Dusty <input type="checkbox"/>	Damp <input type="checkbox"/>
Astro <input type="checkbox"/>	High <input type="checkbox"/>	Smooth <input type="checkbox"/>	Dry <input type="checkbox"/>
Multi <input type="checkbox"/>		Bumpy <input type="checkbox"/>	
		Hard Pack <input type="checkbox"/>	
		Loamy <input type="checkbox"/>	

Race and Vehicle Comments

Qualify: _____ Main: _____ Finish: _____ TQ: _____
 Comments: _____