

CENTRO C4.1

DRIVER: _____

TRACK: _____

SURFACE: _____

DATE: _____

Front End

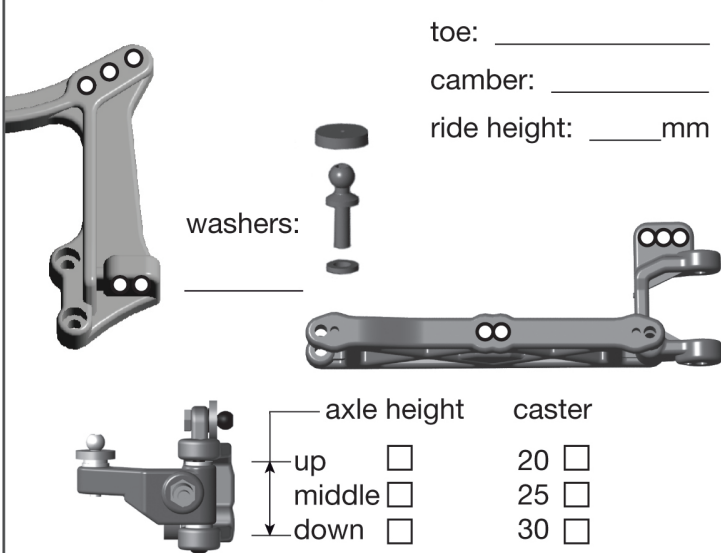

toe: _____
 camber: _____
 ride height: _____ mm

washers: _____

axle height caster

up 20
 middle 25
 down 30

Rear End

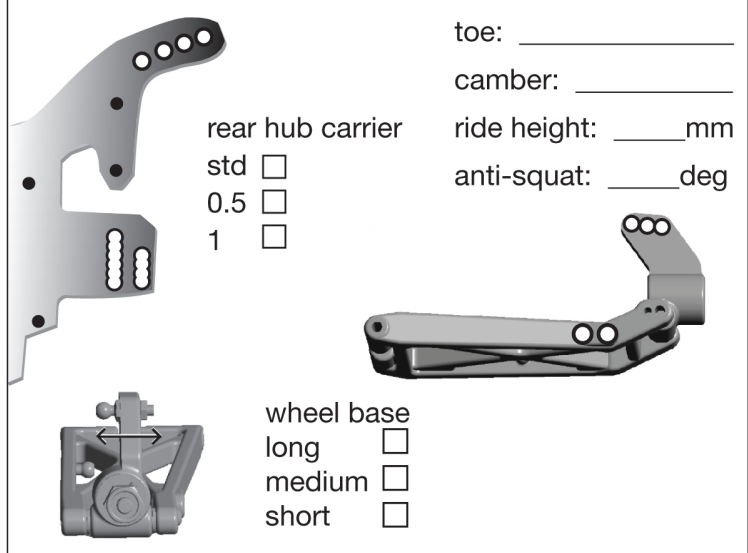

toe: _____
 camber: _____
 ride height: _____ mm
 anti-squat: _____ deg

rear hub carrier
 std
 0.5
 1

wheel base
 long
 medium
 short

Front Shocks

spring _____ piston _____
 shock oil _____ limiter _____

Rear Shocks

spring _____ piston _____
 shock oil _____ limiter _____

Front Tires

tire: _____ compound: _____
 insert: _____ wheel: _____

Rear Tires

tire: _____ compound: _____
 insert: _____ wheel: _____

Electronics

motor & wind: _____
 pinion: _____ spur gear: _____
 batteries: _____ placement: _____
 radio: _____ servo/ expo: _____/_____

throttle/ brake epa: _____/_____
 throttle/ brake expo: _____/_____
 esc: _____ throttle profile: _____
 initial brake _____ drag brake: _____

Body/Wing

body/ wing: _____
 notes: _____

Differential

gear differential/ oil: _____/_____
 ball differential/ setting: _____/_____

Race/ Car/ Notes

qualify: _____ main: _____ finish: _____

Weight distribution

bulkhead option weights

std ackerman lipo holders
 brass under bellcrank rear arm mount
 alloy

bulkhead weights

5g
 10g
 15g

