

### Front Suspension:

**Ride Height:** 17

**Camber:** -1

**Toe:** 0

**Arm Type:** Gull standard

**Tower Type:** Gull

**Caster Block Insert:** 2.5

**Bulkhead Type:** Brass

**Kick-Up Angle:** 25

**Wheel Hex:** Titanium AE

**Notes:**  
 AE alum servo horn- clamping  
 Full AE alum steering  
 Proline front wing

**Anti Roll Bar:**

None

White (0.8mm)

Gray (0.9mm)

Blue (1.0mm)

Other:

**Bump Steer Spacing:** 0

**Axle Height:**

+3

+2

+1

0

**Ball Stud Spacing:** 1mm

**Steering Plate:** kit

**Steering Stop Spacing:** none

**Ball Stud Spacing:** 1mm

**Caster Block Spacing:** 1mm

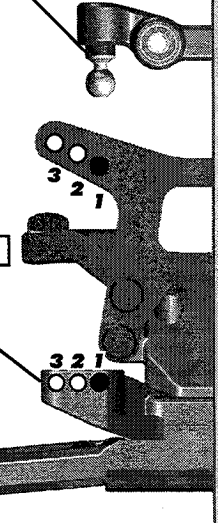
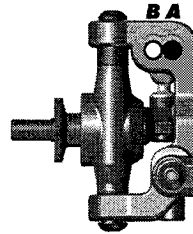
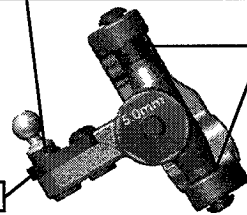
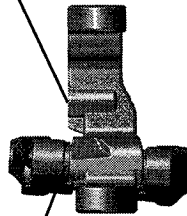

### Rear Suspension:

**Ride Height:** 16mm

**Camber:** -1mm

**Wheel Hex:** 6mm

**Hub Spacing:**  
 Forward  Middle  Back

**Shock Mounting Position:**  
 Front of Arm  Rear of Arm

**Notes:**  
 Schelle rear alum hubs with -2mm caps and inner  
 hole used with no washers  
 AE 67mm driveshafts and axles

**Anti Roll Bar:**

None

White (1.2mm)

Gray (1.3mm)

Blue (1.4mm)

Other:

**Rear Hub Link Setting:**

**Up**

E C A

D B

**Down**

D B

E A

**C Mount Inserts:** 1°  0.5°

**D Mount Inserts:** 1°  0.5°

**Hub Insert:**

+3  +2  +1  0

**Ball Stud Spacing:** 0mm

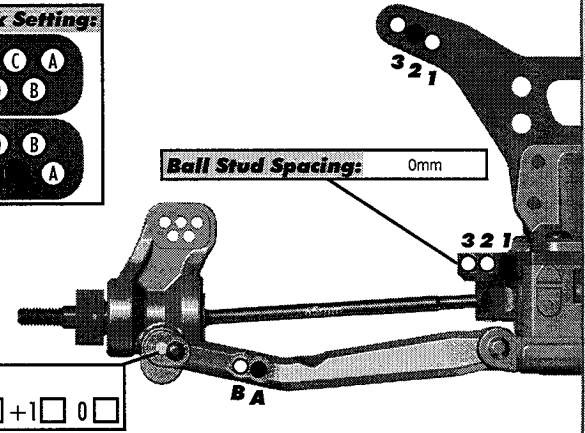

### Electronics:

**Radio:** Futaba 7px      **Servo:** Futaba

**EPA: Throttle:** 100      **% Brake:** 100      %

**ESC:** 510r

**ESC Settings:** full brake, 24k freq, 22 drag brake, 7.4 v bec

**Motor:** Reedy Spec Plus

**Wind:** 13.5      **Timing:** 36

**Pinion:** 28      **Spurs:** 78

**Battery:** Reedy Zappers SG 4800 110c

**Battery Position:** rear

### Drivetrain:

**Transmission:**

**3 Gear:**       **4 Gear:**

**Stand Up:**       **Lay Down:**

**Differential:**

**Ball Diff:**       **Gear Diff:**

**Notes:** 6k AE fluid

**Slipper Clutch:**

**Type:** AE vented

**# of Pads:** 2 lcf

### Shocks:

	Front	Rear
<b>Piston:</b>	2 x 1.6 machined	2 x 1.8 machined
<b>Fluid:</b>	AE 40	AE 32.5
<b>Spring:</b>	AE Purple	AE Blue
<b>Limiters:</b>	1	0
<b>Stroke:</b>	21.5	28.5
<b>Eyelet Length:</b>	short	long
<b>Cup Offset:</b>	5mm	0mm
<b>Notes:</b>	machined internals, kashima bodies	

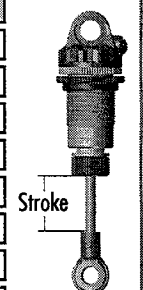

### Track Info:

**Size:** Small  Medium  Large  Extra Large

**Surface:** Dirt  Carpet  Astroturf  Multi Surface

**Traction:** Low  Medium  High  Very High

**Moisture:** Dry  Damp  Wet

**Condition:** Indoor  Outdoor  Dusty  Hard Packed   
 Bumpy  Grooved  Smooth  Loamy

**Temperature:** Ambient: 70      Track:

**Notes:**

### Tires:

**Front Tires:** PL wedge squared

**Front Compound:** z3

**Front Insert:** none

**Rear Tires:** PL Prism

**Rear Compound:** z3

**Rear Insert:** stock white foam

**Wheel (F/R):** AE slim front/AE 12mm rear

**Notes:**

### Body, Wing, Weight:

**Body:** stock

**Wing:** stock

**Wing Angle:** 0°  3°  6°

**Servo Weights:**  
 None  Aluminum  Steel  Other

**Electronic Weights:** AE carbon

None  Aluminum  Steel  Other

**Total Vehicle Weight:**

### Vehicle Comments:

**Notes:** Schelle battery strap-pistons-ceramic gearbox bearings used