

Front Suspensions:

Camber: -1

Total Toe: 0

Ride Height: 24 mm

Arm Type: Flat, Standard Composite

Tower Type: Flat, Standard Composite

Caster Block Insert: 5

Kick-Up Angle: 25

Notes: Aluminum front pin brace; Plastic shock caps; Standard composite caster blocks and spindles

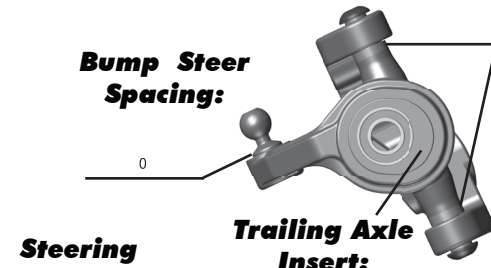

Axle Height:
Up
Middle
Down

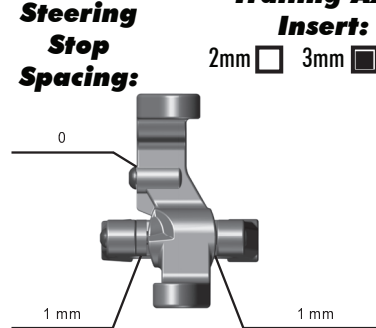

Caster Block Spacing:

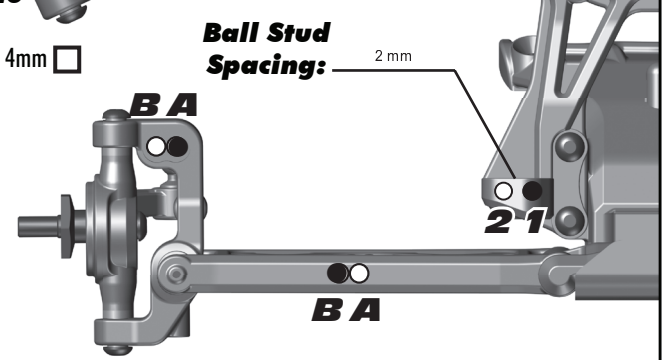

Rear Suspension:

Camber: -1

Ride Height: 24 mm

Hub Spacing:
Forward Middle Back

Notes: Standard composite arms, hubs, tower & u-brace; Factory Team aluminum rear hubs (Front row, inside, 1 mm washers); Factory Team "C" & "D" Plate

Anti Roll Bar:
None
Black (1.2mm)
Silver (1.3mm)
Gold (1.4mm)

Rear Hub Link Setting:

A Up
C Down
B Up
A Down



Arm Mount: 3+2

Inboard Toe: 3

Anti-Squat: 2

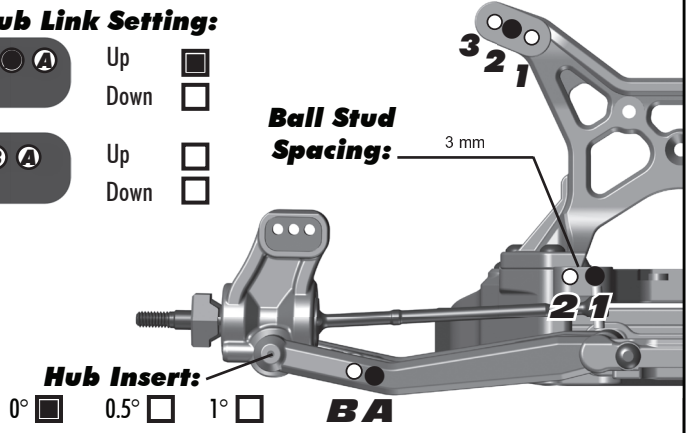

Hub Insert: 0° 0.5° 1°

Electronics:

Radio: Airtronics M12 **Servo:** Sanwa 94661

EPA: Throttle: 100 % **Brake:** 82 %

ESC: Reedy Prototype (14 gauge wire)

ESC Settings: _____

Motor: Reedy Sonic Mach2

Wind: 8.0 **Timing:** 20

Pinion: 22 **Spur:** 78

Battery: Reedy SQ #314

Battery Position: Back

Drivetrain:

Differential:
Ball:
Setting: _____
Gear:
Oil: _____

Slipper Clutch:

Type: Associated

of Pads: 2

Notes: Inner diameter of pad trimmed 2 mm

Shocks:

	Front	Rear
Piston:	3 x 1.4 Tapered	3 x 1.4 Tapered
Oil:	35	32
Spring:	Green	White
Limiters:	2	2
Cup Offset:	5 mm	5 mm
Stroke:	20 mm	26.5 mm
Free Length:	N/A	N/A
Notes:	#91493 Low Friction X-Rings	

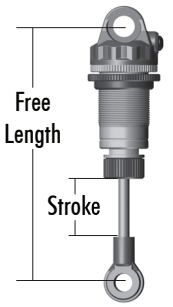

Track Info:

Size: Small Medium Large Extra Large

Surfaces: Dirt Carpet Astroturf Multi Surface

Traction: Low Medium High Very High

Moisture: Dry Damp Wet

Condition: Indoor Outdoor Dusty Hard Packed
Bumpy Grooved Smooth Loamy

Temperature: Ambient: 70 F **Track:** 70 F

Notes: _____

Tires:

Tires (F/R): JConcepts Groovies / JConcepts Double Dees

Compound (F/R): Green / Green

Insert (F/R): Stock / Stock

Wheel (F/R): Associated Hex / Associated Hex

Notes: _____

Body & Wing:

Body: Associated B5

Wing: JConcepts High Clearance 6.5"

Wing Angle: 0° 3° 6°

Notes: Wing lip cut to 2 lines

Race Results:

Qualify: _____ **Main:** _____

Finish: _____ **TQ:**

Best Lap Time: _____

Vehicle Comments:

Total Vehicle Weight: 1596g