

### Front Suspensions:

**Camber:** -2

**Total Toe:** + 1/2

**Ride Height:** 19 mm

**Arm Type:** Flat, Hard #91399

**Tower Type:** Flat, Standard #91374

**Caster Block Insert:** 5\*

**Kick-Up Angle:** 25\* Aluminum #91367

**Wheel Hex:** 4mm Clamping #91409

**Notes:** Top Plate, Standard #91362

Chassis Plate, Standard #91512

Caster Blocks, Standard #91400

Steering Blocks, Standard #91404

Caster Block Bushings, Offset #91403

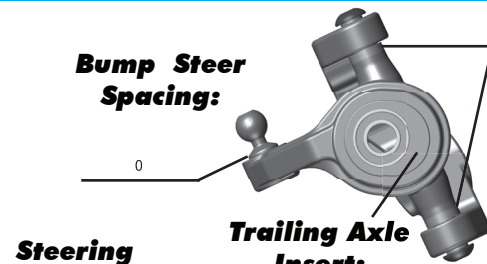

**Axle Height:**

Up

Middle

Down

**Ball Stud Spacing:** 0 mm

**Steering Stop Spacing:** 0 mm

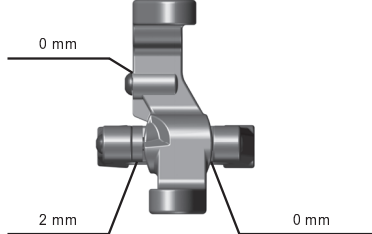

**Caster Block Spacing:** 0 mm

**Ball Stud Spacing:** 1.5 mm

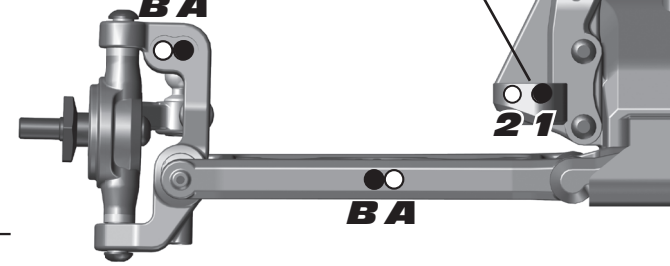

Reset Forms

### Rear Suspension:

**Camber:** -1/2

**Ride Height:** 19 mm

**Wheel Hex:** 7mm #91610

**Hub Spacing:** Forward  Middle  Back

**Notes:** B5 Rear Arms, Hard #91412

Factory Team Aluminum Hubs #91549 (Back Row Inside +3mm)

Aluminum "C" #91522 & "D" #91524 Arm Mounts (+1mm Raised)

**Anti Roll Bar:**

None

Black (1.2mm)

Silver (1.3mm)

Gold (1.4mm)

**Rear Hub Link Setting:**

**A**  Up  Down

**B**  Up  Down



**Arm Mount:**

**Inboard Toe:** 3

**Anti-Squat:** 1

**Insert (D):** GHEA +2 mm

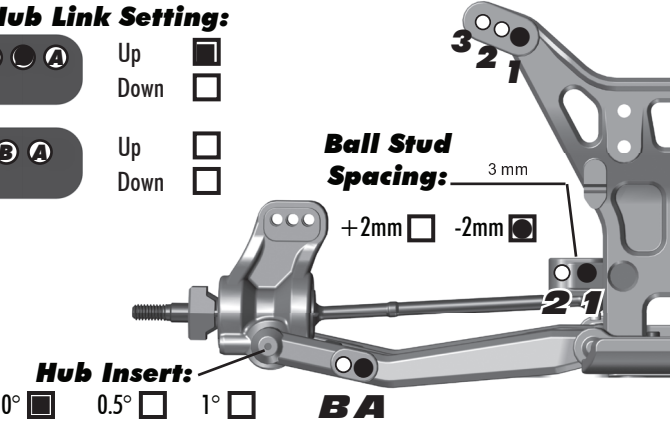

### Electronics:

**Radio:** Airtronic M12S **Servo:** Sanwa 94671

**EPA: Throttle:** 100 % **Brake:** 100 %

**ESC:** Team Orion

**ESC Settings:** N/A

**Motor:** Team Orion VST2 Lightweight

**Wind:** 7.5 **Timing:** 0\*

**Pinion:** 22 **Spur:** 81

**Battery:** Team Orion 4500 Shorty

**Battery Position:** 9 mm From Rear (Battery Taped In)

### Drivetrain:

**Differential:**

**3 Gear:**  **4 Gear:**

**Ball Diff:**  **Gear Diff:**

**Notes:** 3,000 Diff Fluid

### Slipper Clutch:

**Type:** Associated V2 Slipper Plates #7495

**# of Pads:** 2

**Notes:** B44 Slipper Spring #9739

### Shocks:

	Front	Rear
<b>Piston:</b>	2 x 1.6 Flat V2	3 x 1.4 Flat V2
<b>Oil:</b>	32.5 wt	27.5 wt
<b>Spring:</b>	Blue	Green
<b>Limiters:</b>	2	1
<b>Cup Offset:</b>	5 mm	5 mm
<b>Stroke:</b>	20.25 mm	27.0 mm
<b>Free Length:</b>	N/A	N/A
<b>Notes:</b>	Kashima Shock Bodies, Chrome V2 Shafts, X-Rings	

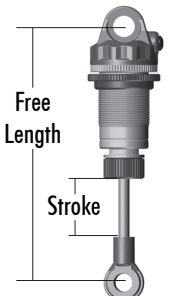

### Track Info:

**Size:** Small  Medium  Large  Extra Large

**Surfaces:** Dirt  Carpet  Astroturf  Multi Surface

**Traction:** Low  Medium  High  Very High

**Moisture:** Dry  Damp  Wet

**Condition:** Indoor  Outdoor  Dusty  Hard Packed

Bumpy  Grooved  Smooth  Loamy

**Temperature: Ambient:** 80F **Track:** 80F

**Notes:** 100% Clay

### Tires:

**Tires (F/R):** AKA Slicks / AKA Slicks

**Compound (F/R):** Clay / Clay

**Insert (F/R):** AKA Black / AKA Black

**Wheel (F/R):** Team Associated 61mm Hex #91573 / Team Associated 61mm Hex #91571

**Notes:**

### Body, Wing & Chassis:

**Body:** Team Associated Kit #91538

**Wing:** Team Associated Kit #91471

**Wing Angle:** 0°  3°  6°

**Chassis:** **#91510 - B5M**  **#91511 - B5M Lite**

### Race Results:

**Qualify:** 1 **Main:** 1

**Finish:** 1 **TQ:**

**Best Lap Time:**

### Vehicle Comments:

Factory Team Bearing Set #91553; CVA Axles Shims #91605; Plastic Shock Caps #91449; Shock Bushings, Aluminum #91446;

**Total Vehicle Weight:** 1554g