

Driver: _____ Date: _____

Track: _____ Event: _____

FRONT SUSPENSION:

Camber: _____
 Total Toe: _____
 Ride Height: _____
 Arm Type: _____
 Tower Type: _____
 Caster Block Insert: _____
 Kick-Up Angle: _____
 Wheel Hex: _____

Notes: _____

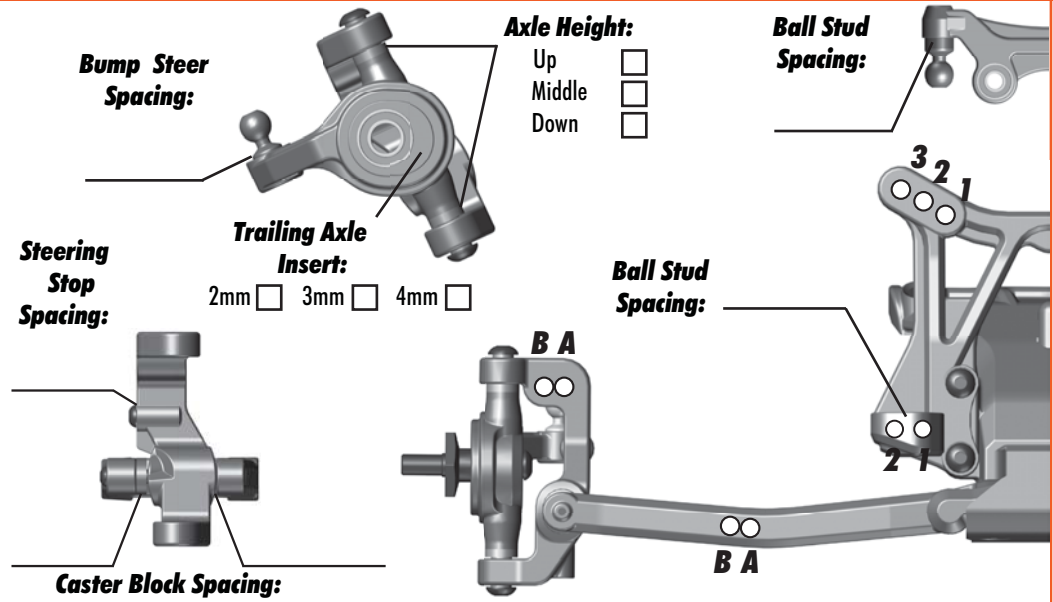

REAR SUSPENSION:

Camber: _____
 Ride Height: _____
 Wheel Hex: _____
 Hub Spacing: _____

Forward Middle Back

Notes: _____

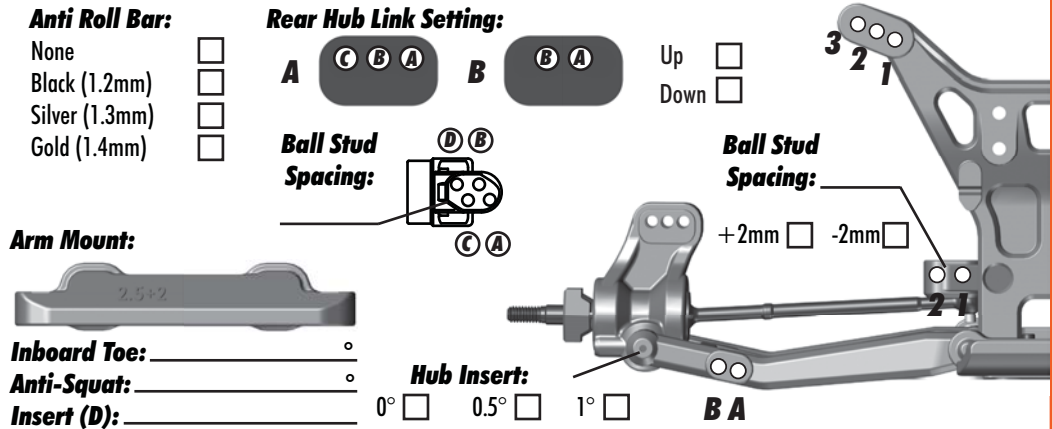

ELECTRONICS:

Radio: _____ Servo: _____
 EPA: Throttle: _____ % Brake: _____ %
 ESC: _____
 ESC Settings: _____
 Motor: _____
 Wind: _____ Timing: _____
 Pinion: _____ Spur: _____
 Battery: _____
 Battery Position: _____

DRIVETRAIN:

Differential: Ball Gear
Gearbox: 3 Gears 4 Gears
 Notes: _____

SLIPPER CLUTCH:

Type: _____
 # of Pads: _____
 Notes: _____

SHOCKS:

	Front	Rear
Piston:		
Oil:		
Spring:		
Limiters:		
Cup Offset:		
Stroke:		
Free Length:		
Notes:		

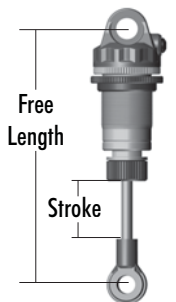

TRACK INFO:

Size: Small Medium Large Extra Large
Surfaces: Dirt Carpet Astroturf Multi Surface
Traction: Low Medium High Very High
Moisture: Dry Damp Wet
Condition: Indoor Outdoor Dusty Hard Packed
 Bumpy Grooved Smooth Loamy

Temperature: Ambient: _____ Track: _____
 Notes: _____

TIRES:

_____:F - Tires - R: _____
 _____:F - Compound - R: _____
 _____:F - Insert - R: _____
 _____:F - Wheel - R: _____
 _____:F - Notes - R: _____

BODY & WING:

Body: _____
 Wing: _____
 Wing Angle: 0° 3° 6° _____
 Notes: _____

RACE RESULTS:

Quality: _____ Main: _____
 Finish: _____ TQ:
 Best Lap Time: _____

VEHICLE COMMENTS:

Total Vehicle Weight: _____