

Front Suspension:

- Camber: _____ °
- Total Toe: _____ °
- Ride Height: _____
- Arm Type: _____
- Tower Type: _____
- Caster Block Insert: _____ °
- Kick-Up Angle: _____ °
- Wheel Hex: _____

Notes: _____

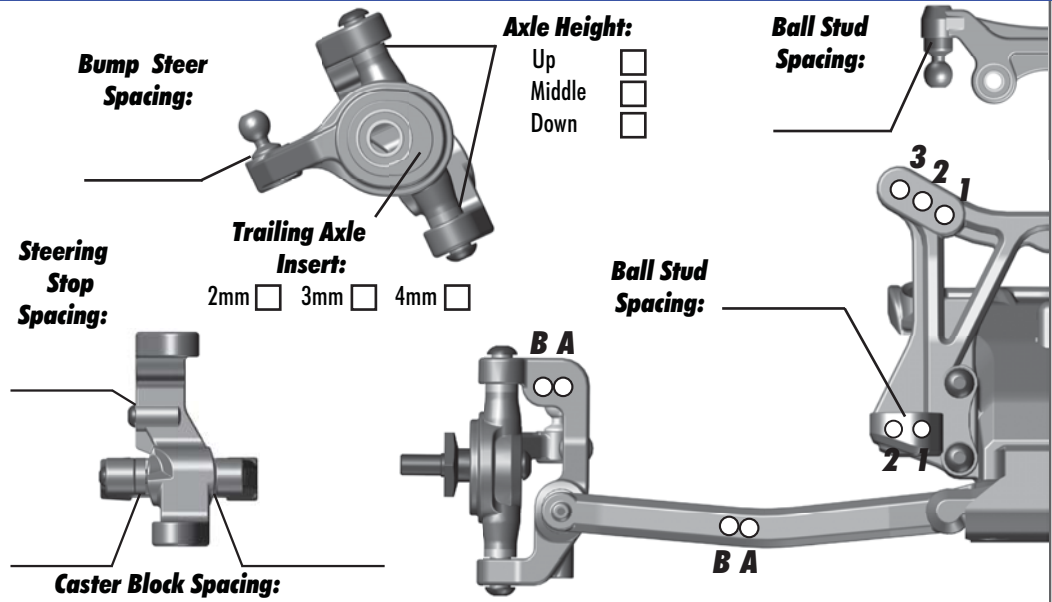

Rear Suspension:

- Camber: _____ °
- Ride Height: _____
- Wheel Hex: _____
- Hub Spacing: _____

- Forward Middle Back

Notes: _____

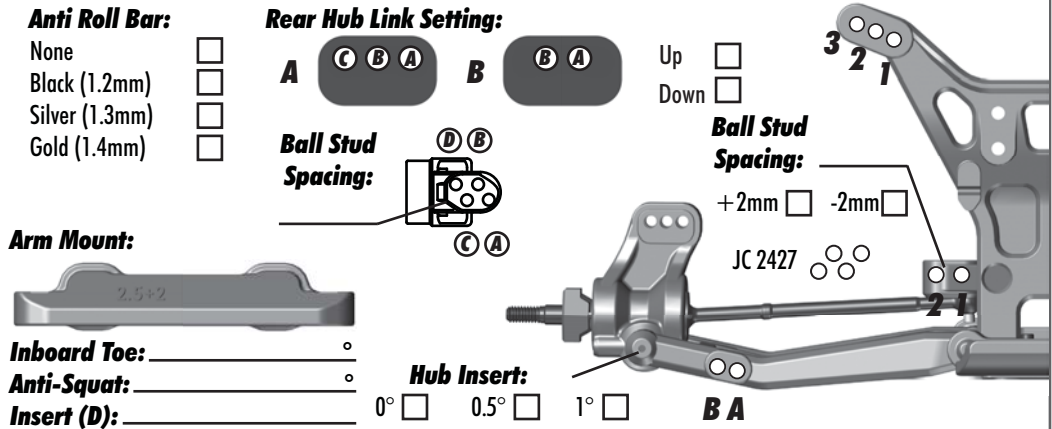

Electronics:

- Radio: _____ Servo: _____
- EPA: Throttle: _____ % Brake: _____ %
- ESC: _____
- ESC Settings: _____
- Motor: _____
- Wind: _____ Timing: _____
- Pinion: _____ Spur: _____
- Battery: _____
- Battery Position: _____

Drivetrain:

- Differential:**
 Ball Gear
- Gearbox:**
 3 Gears 4 Gears
- Notes: _____

Slipper Clutch:

- Type: _____
- # of Pads: _____
- Notes: _____

Shocks:

	Front	Rear
Piston:		
Oil:		
Spring:		
Limiters:		
Cup Offset:		
Stroke:		
Free Length:		
Notes:		

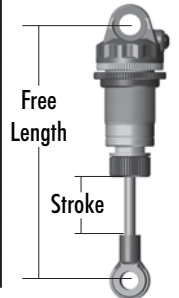

Track Info:

- Size:** Small Medium Large Extra Large
- Surfaces:** Dirt Carpet AstroTurf Multi Surface
- Traction:** Low Medium High Very High
- Moisture:** Dry Damp Wet
- Condition:** Indoor Outdoor Dusty Hard Packed
 Bumpy Grooved Smooth Loamy

Temperature: Ambient: _____ Track: _____

Notes: _____

Tires:

- _____ :F - Tires - R:
- _____ :F - Compound - R:
- _____ :F - Insert - R:
- _____ :F - Wheel - R:
- _____ :F - Notes - R:

Body & Wing:

- Body: _____
- Wing: _____
- Wing Angle: 0° 3° 6°
- Notes: _____

Race Results:

- Quality: _____ Main: _____
- Finish: _____ TQ:
- Best Lap Time: _____

Vehicle Comments:

Total Vehicle Weight: _____