

Front Suspensions:

Camber: -2.5
Total Toe: 0
Ride Height: 19 mm
Arm Type: Gull Wing, Standard Composite
Tower Type: Gull Wing, Standard Composite
Caster Block Insert: 0
Kick-Up Angle: 25

Notes:

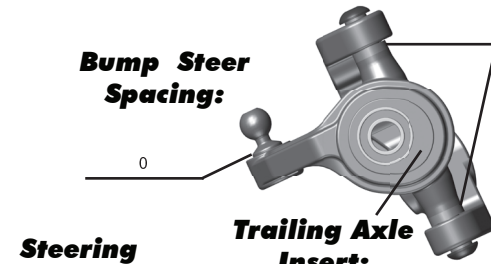

Axle Height:
Up
Middle
Down



Trailing Axle Insert:
2mm 3mm 4mm

Ball Stud Spacing: 0

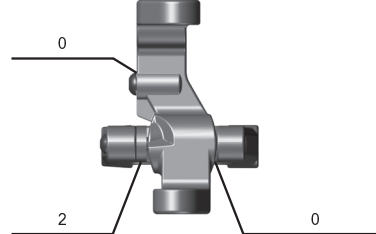

Caster Block Spacing:

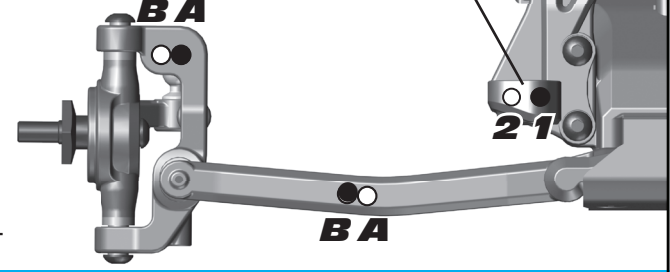

Rear Suspension:

Camber: -2.5
Ride Height: 20 mm
Hub Spacing:
Forward Middle Back

Notes: SC10 Silver anti-roll bar

Anti Roll Bar:
None
Black (1.2mm)
Silver (1.3mm)
Gold (1.4mm)

Rear Hub Link Setting:
A C B A Up
Down
B A Up
Down

Ball Stud Spacing: 1.5mm



Arm Mount:
Inboard Toe: 3
Anti-Squat: 1

Hub Insert:
0° 0.5° 1°

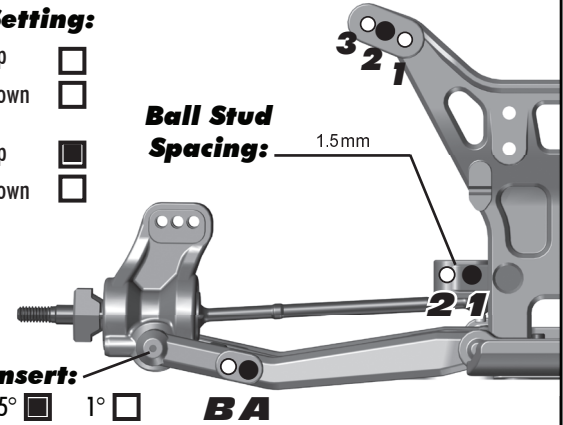

Electronics:

Radio: M12 **Servo:** Sanwa
EPA: Throttle: 100 % **Brake:** 65 %
ESC: HW 3.1
ESC Settings: Punch:8 Boost:0 Turbo:10%
Motor: Reedy Sonic Mach2
Wind: 7.0 **Timing:** 25
Pinion: 23 **Spur:** STD
Battery: Reedy #602 Shorty
Battery Position: 1 Thin Pad Front

Drivetrain:

Differential:
Ball:
Setting: _____
Gear:
Oil: 2000

Slipper Clutch:

Type: STD
of Pads: _____
Notes: Tight

Shocks:

	Front	Rear
Piston:	2 x 1.6	2 x 1.7
Oil:	37.5	32.5
Spring:	Red	Blue
Limiters:	2	2
Cup Offset:	STD	STD
Stroke:	no limiters	no limiters
Free Length:	STD	STD
Notes:		

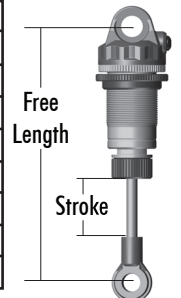

Track Info:

Size: Small Medium Large Extra Large
Surfaces: Dirt Carpet Astroturf Multi Surface
Traction: Low Medium High Very High
Moisture: Dry Damp Wet
Condition: Indoor Outdoor Dusty Hard Packed
Bumpy Grooved Smooth Loamy

Temperature: Ambient: 20 **Track:** 20

Notes:

Tires:

Tires (F/R): Pro-Line Pinpoint (Handout) / Pro-Line Pinpoint (Handout)
Compound (F/R): N/A / N/A
Insert (F/R): None / Standard
Wheel (F/R): Associated Hex / Associated Hex
Notes: Front wheel ribs cut off and inside ring cut off

Body & Wing:

Body: Associated B5M
Wing: Associated B5M; Front Wing
Wing Angle: 0° 3° 6°
Notes:

Race Results:

Qualify: 9 **Main:** A
Finish: 7 **TQ:**
Best Lap Time: 21.1

Vehicle Comments:

10g In Front Of Servo
Total Vehicle Weight: 1580