

Front Suspensions:

Camber: -1

Total Toe: 0

Ride Height: 24 mm

Arm Type: #91398 Flat, Standard

Tower Type: #91373 Flat, Standard

Caster Block Insert: 5

Kick-Up Angle: 25 Aluminum, #91367

Wheel Hex: Stock

Notes: #91373 Standard Front Hinge Pin Brace

#91440 Standard Front Caster Blocks

#91404 Standard Steering Blocks

#91362 Standard Top Plate

#91514 Chassis Cradle, Standard

#91512 Chassis Plate, Standard

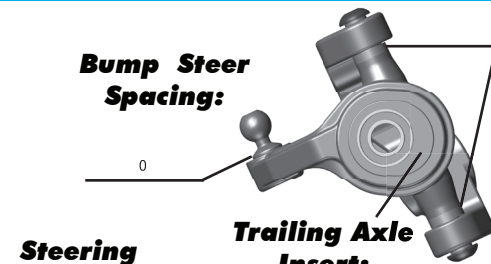

Axle Height:

Up

Middle

Down



Steering Stop Spacing: 0

Caster Block Spacing: 0

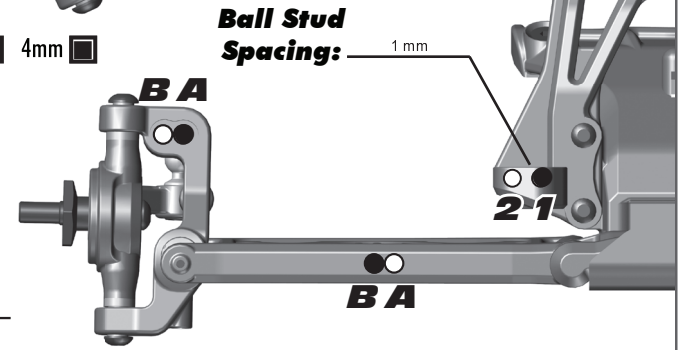
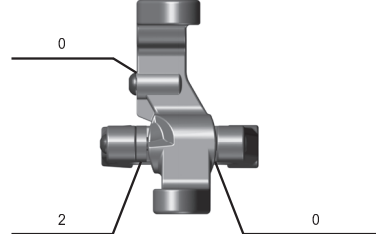

Rear Suspension:

Camber: -1

Ride Height: 24 mm

Wheel Hex: #91410 Clamping Hex 7.0mm

Hub Spacing: Forward Middle Back

Notes: #91412 Rear Arms, Standard

#91548 Factory Team 0° Aluminum Hubs (Back Row Inside + 3 mm)

#91520 Factory Team Aluminum Camber Link Mount (Low + 3 mm)

#91522 & #91524 Factory Team Aluminum Arm Mount (C) & (D)

#91518 Standard Rear Tower

Anti Roll Bar:

None

Black (1.2mm)

Silver (1.3mm)

Gold (1.4mm)

Rear Hub Link Setting:

A C B A Up Down

B A Up Down

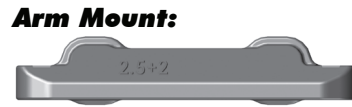

Arm Mount:

Inboard Toe: 3

Anti-Squat: 1

Insert (D): Arrow In

Hub Insert: 0° 0.5° 1°

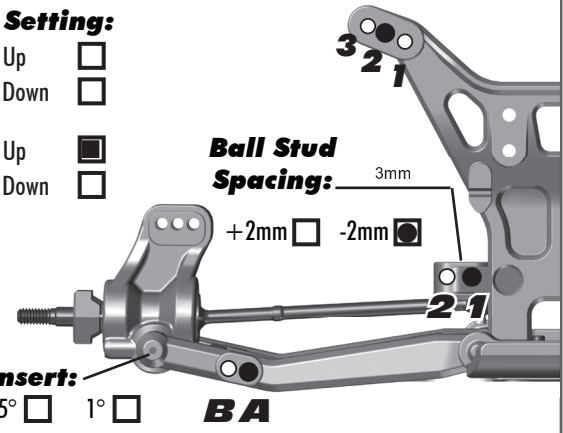

Electronics:

Radio: Airtronics M12 **Servo:** Reedy 1206

EPA: Throttle: 100 % **Brake:** 100 %

ESC: Reedy Blackbox 410R

ESC Settings: See Brent Thielke Standard Setup Sheet

Motor: Reedy Sonic 540M3

Wind: 8.0 **Timing:** 20°

Pinion: 23 **Spur:** 81

Battery: Reedy Wolf Pack Shorty #738

Battery Position: 2 Thin Back / 1 Thick Front

Drivetrain:

Differential:

3 Gear: **4 Gear:**

Ball Diff: **Gear Diff:**

Notes: Standard To Tight

Slipper Clutch:

Type: #7485 Factory Team V2 Slipper Hubs

of Pads: 2

Notes:

Shocks:

	Front	Rear
Piston:	2 x 1.6 Flat V2	3 x 1.4 Flat V2
Oil:	32 wt	30 wt
Spring:	AE Gray	AE Green
Limiters:	2	2
Cup Offset:	5 mm	5 mm
Stroke:	21.0 mm	27.0 mm
Free Length:	N/A	N/A
Notes:		

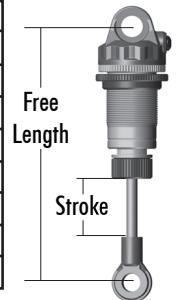

Track Info:

Size: Small Medium Large Extra Large

Surfaces: Dirt Carpet Astroturf Multi Surface

Traction: Low Medium High Very High

Moisture: Dry Damp Wet

Condition: Indoor Outdoor Dusty Hard Packed

Bumpy Grooved Smooth Loamy

Temperature: Ambient: 75° **Track:** 75°

Notes:

Tires:

Tires (F/R): JConcepts Bar Flies / JConcepts Bar Flies

Compound (F/R): Gold / Gold

Insert (F/R): AKA Red / AKA Red

Wheel (F/R): Team Associated Hex 61 mm / Team Associated Hex 61 mm

Notes:

Body, Wing & Chassis:

Body: Team Associated Kit

Wing: Team Associated Kit

Wing Angle: 0° 3° 6°

Chassis: #91510 - B5M #91511 - B5M Lite

Race Results:

Qualify: 2 **Main:** A

Finish: 1 **TQ:**

Best Lap Time: 18.3

Vehicle Comments:

#91551 Factory Team Bearing Set; #91545 Factory Team Graphite Battery Strap; #91446 Factory Team Shock Bushings; #91547 Factory Team Milled Motor Plate; #91600 Factory Team Titanium Screw Kit; #91576 & #91578 Kashima V2 Shock Bodies; #91616 & #91620 V2 Chrome Shock Shafts; #91450 Aluminum Shock Caps; #91493 X-Rings

Total Vehicle Weight: 1565g