

Front Suspensions:

Camber: -1 °

Total Toe: 0 °

Ride Height: 21 mm

Arm Type: Flat

Tower Type: Flat (No Nub Between Shock Mounting Location)

Caster Block Insert: 5 °

Kick-Up Angle: 25 °

Wheel Hex: Stock

Notes: Aluminum Bulkhead, Pins trimmed, no front brace.

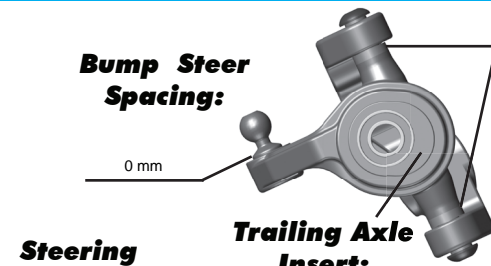

Axle Height:

Up

Middle

Down



Steering Stop Spacing:

2mm 3mm 4mm

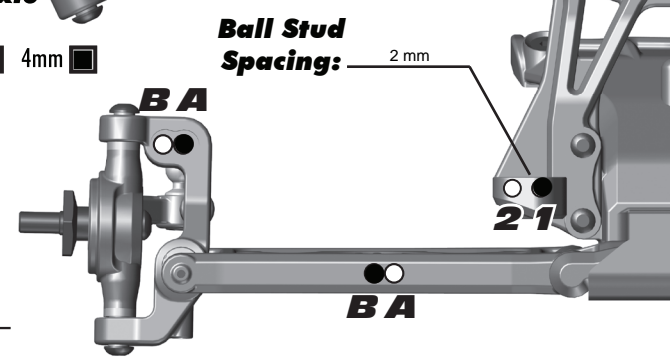
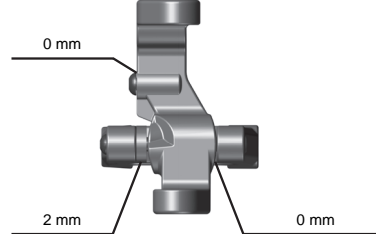

Rear Suspension:

Camber: -1 °

Ride Height: 21 mm

Wheel Hex: 7.0 mm

Hub Spacing:

Forward Middle Back

Notes: B5 Rear Arms (Indicated By Two Sway Bar Pivot Balls)

Aluminum C/D plates

Aluminum hubs, #2 hole w/ 3mm

Anti Roll Bar:

None

Black (1.2mm)

Silver (1.3mm)

Gold (1.4mm)

Rear Hub Link Setting:

A C A Up Down

B B A Up Down

Arm Mount:



Inboard Toe: 3 °

Anti-Squat: 1 °

Insert (D): 0° 0.5° 1°

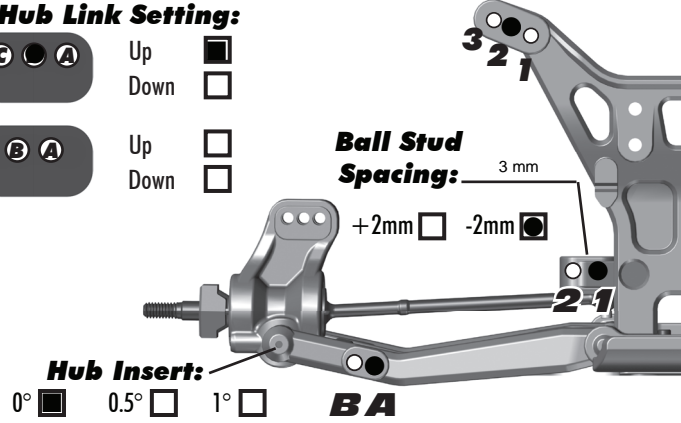

Electronics:

Radio: _____ **Servo:** _____

EPA: Throttle: _____ % **Brake:** _____ %

ESC: _____

ESC Settings: _____

Motor: Reedy 17.5 M3

Wind: N/A **Timing:** 45°

Pinion: 32 **Spur:** 69

Battery: Reedy Shorty

Battery Position: Taped, 10mm forward from rear

Drivetrain:

Differential:

3 Gear: **4 Gear:**

Ball Diff: **Gear Diff:**

Notes: _____

Slipper Clutch:

Type: Triad

of Pads: _____

Notes: Locked

Shocks:

	Front	Rear
Piston:	Wht Base	Blk Base
Oil:	32.5 wt	32.5 wt
Spring:	White	Green
Limiters:	2	2
Cup Offset:	5 mm	5 mm
Stroke:	21 mm	27.0 mm
Free Length:	N/A	N/A
Notes:	RCShox Triflex Pistons - Black inserts	

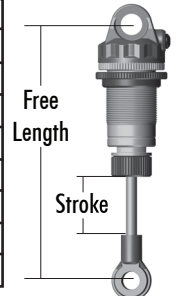

Track Info:

Size: Small Medium Large Extra Large

Surfaces: Dirt Carpet Astroturf Multi Surface

Traction: Low Medium High Very High

Moisture: Dry Damp Wet

Condition: Indoor Outdoor Dusty Hard Packed

Bumpy Grooved Smooth Loamy

Temperature: Ambient: 50F **Track:** 50F

Notes: _____

Tires:

Tires (F/R): Proline 2.2 Electron / Proline 2.2 Electron

Compound (F/R): MC (Clay) / MC (Clay)

Insert (F/R): PL / PL

Wheel (F/R): AE Hex / AE Hex

Notes: One set of tires used ALL DAY

Body, Wing & Chassis:

Body: FTW B5M

Wing: Proline Trifecta

Wing Angle: 0° 3° 6°

Chassis: **#91510 - B5M** **#91511 - B5M Lite**

Race Results:

Qualify: 1 **Main:** A

Finish: 1 **TQ:**

Best Lap Time: 14.0

Vehicle Comments:

Total Vehicle Weight: 1515G