

SETUP SHEET **RC10B3**

2 TEAM ASSOCIATED

PETIT R/C - <http://www.petitrc.fr.st>

driver Philippe QUERO

track / city VIERZON

event 4eme Manche CF 2000 date 04/06/2000

FRONT SUSPENSION

- ① CASTER 25° 30°
- ② FRONT RIDE HEIGHT ARMS LEVEL other _____
- ③ CAMBER - 1°
- ④ ANTI ROLL BAR NONE
 THICK
 THIN
 other _____
- ⑤ TOE-IN 0° TOE-OUT 0°
- ⑥ BUMP STEER SPACERS 0
- ⑦ STEERING ACKERMAN STD
 OPTICAL

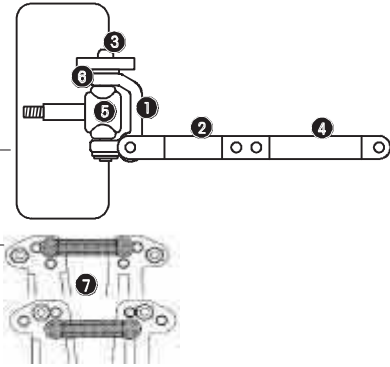

FRONT SHOCKS

- BODY STD GRAY other _____
- BODY .89 other _____
- SHAFT .71 other _____
- SHAFT STD Unobtainium
- PISTON # 2
- LIMITERS, inside _____
- LIMITERS, outside _____
- SPRING Silver
- OIL 25 wt

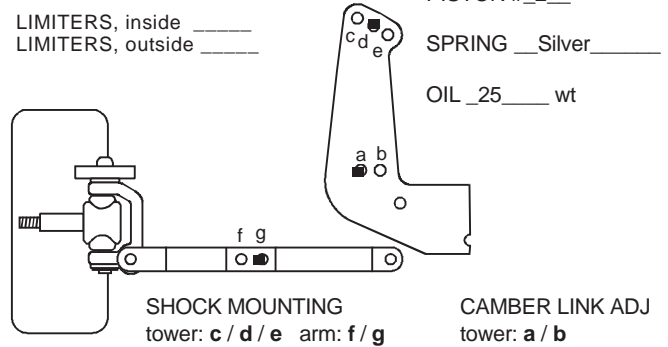

REAR SUSPENSION

- ① CAMBER _____°
- ② REAR RIDE HEIGHT
 BONES LEVEL other _____
 MIP CVD's DOGBONES UNIVERSALS
- ③ TOE-IN / ANTI-SQUAT 2-3 3-1.5 3-0 mour
- ④ ANTI ROLL BAR NONE
 THICK
 THIN
 other _____

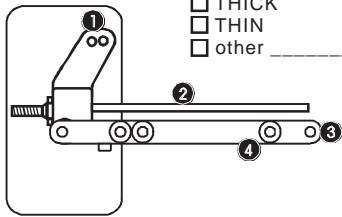

WHEELBASE ADJUSTMENT

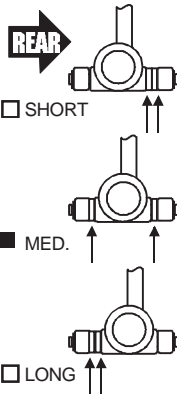

REAR SHOCKS

- BODY STD GRAY other _____
- BODY 1.32 other _____
- SHAFT 1.02 other _____
- SHAFT STD Unobtainium
- PISTON # 1
- LIMITERS, in _____
- LIMITERS, out _____
- SPRING Vert
- OIL 25 wt
- SHOCK MOUNTING tower: **e / f / g** arm: **h / i**
- CAMBER LINK ADJ on tower: **a / b** arm: **c / d**

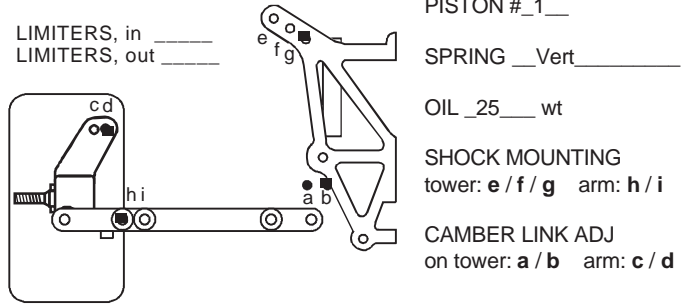

OTHER

- WEIGHT IN BULKHEAD 10 Grs
- BODY Standart WING
- FRONT TIRES Pro-Line 8175 M3 FOAM Oui
- REAR TIRES Losi IFMAR Stud Red FOAM Oui
- FRONT WHEELS 1 PC. 3 PC. other _____
- REAR WHEELS 1 PC. 3 PC. other _____
- CHASSIS STD SHORT LONG GRAPHITE

MOTOR NAME CORALLY 12*3 Silver PINION T SPUR T
BRUSHES _____ SPRING _____

NOTES _____

SLIPPER ASSOC. HYDRA VISCUOUS OIL _____

BATTERIES ORION VMAX PLACEMENT FRONT MIDDLE REAR

RADIO M ZECH SPD. CONT. Novak Cyclone SERVO KO 1001

TRACK CONDITIONS

- SURFACE smooth bumpy BUMPS: _____
- TRACTION low med. high
- COMPOSITION
 sandy soft dirt grass clay other _____
 wet dry dusty other _____
- other: _____

revision 9/14/98

RACE COMMENTS

MAIN A PLACE 9 TQ

NOTES 3 temps des qualifications

CAR COMMENTS

NOTES Utilisation du nouveau support Arrière