

SETUP SHEET RC10B3

TEAM ASSOCIATED

driver __BONNET Jérôme__

track / city __Maisons Alfort__

event __4th Round French CHampionship__ date __June 1st & 2nd 2002__

FRONT SUSPENSION

- 1 CASTER 25° 30°
- 2 FRONT RIDE HEIGHT ARMS LEVEL other _____
- 3 CAMBER __ - 1__ °
- 4 ANTI ROLL BAR NONE
 THICK
 THIN
 other _____
- 5 TOE-IN __ + 1__ ° TOE-OUT _____ °
- 6 BUMP STEER SPACERS __ 0__
- 7 STEERING ACKERMAN STD
 OPTIONAL

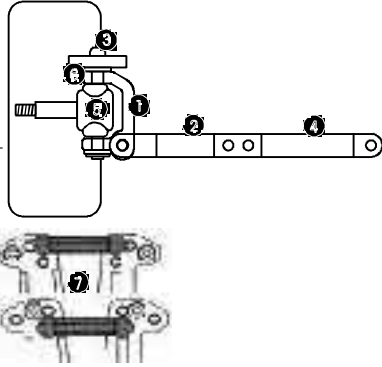

FRONT SHOCKS

- BODY STD GRAY other _____
- BODY .89 other _____
- SHAFT .71 other _____
- SHAFT STD Unobtainium

LIMITERS, inside __ 2__
 LIMITERS, outside __ 0__

PISTON # __ 2__

SPRING __ BLUE__

OIL __ 35__ wt

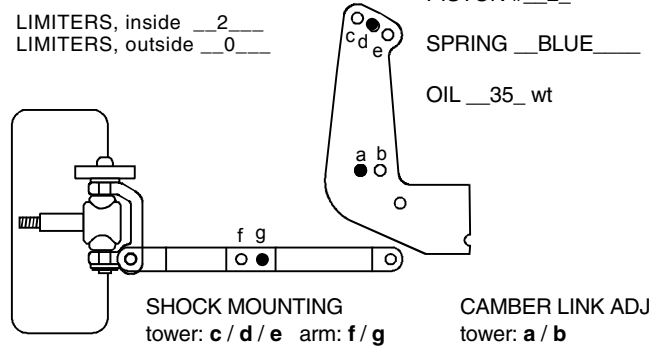

SHOCK MOUNTING
tower: c / d / e arm: f / g

CAMBER LINK ADJ
tower: a / b

REAR SUSPENSION

- 1 CAMBER __ - 1.5__ °
- 2 REAR RIDE HEIGHT
- BONES LEVEL other _____
- MIP CVD's DOGBONES UNIVERSALS
- 3 TOE-IN / ANTI-SQUAT 2-3 3-3 3-0 mount
 3-1.5 mount
- 4 ANTI ROLL BAR NONE
 THICK
 THIN
 other _____

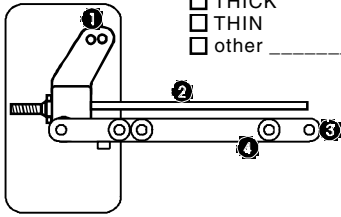

WHEELBASE ADJUSTMENT

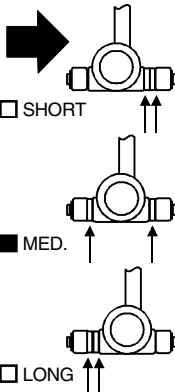

REAR SHOCKS

- BODY STD GRAY other _____
- BODY 1.32 other _____
- SHAFT 1.02 other _____
- SHAFT STD Unobtainium

LIMITERS, in __ 0__
 LIMITERS, out _____

PISTON # __ N°1__

SPRING __ SILVER__

OIL __ 30__ wt

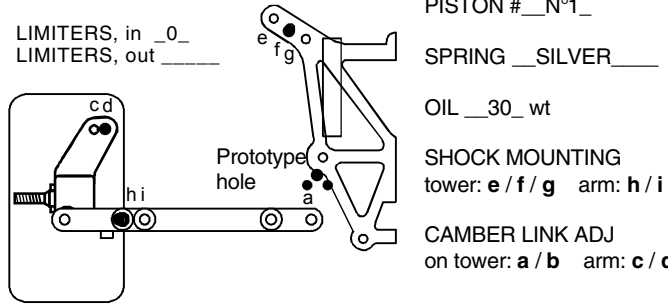

SHOCK MOUNTING
tower: e / f / g arm: h / i

CAMBER LINK ADJ
on tower: a / b arm: c / d

OTHER

WEIGHT __ 20 G__ IN BULKHEAD WING

BODY __ Pro Line Deja Vu Tu__

FRONT TIRES __ Medial Pro Crysp Indoor__ FOAM __ YES__

REAR TIRES __ Medial Pro Crysp Indoor__ FOAM __ YES__

FRONT WHEELS 1 PC. 3 PC. other __ 2.15__

REAR WHEELS 1 PC. 3 PC. other _____

CHASSIS STD SHORT LONG GRAPHITE

MOTOR NAME __ Reedy Fury MW 12x3__ PINION __ 20_T__ SPUR __ 81_T__
 BRUSHES __ Reedy Quazar #729__ SPRING __ Std__

NOTES _____

SLIPPER ASSOC. HYDRA VISCUOUS OIL _____

BATTERIES __ Peak__ PLACEMENT FRONT MIDDLE REAR

RADIO __ Futaba 3VC__ SPD. CONT. __ LRP_V6__ SERVO __ Ko 2015__

TRACK CONDITIONS

SURFACE smooth bumpy BUMPS: _____

TRACTION low med. high

COMPOSITION

sandy soft dirt grass clay other _____

wet dry dusty other _____

other: _____

RACE COMMENTS

MAIN __ A__ PLACE __ 4__ TQ

NOTES _____

CAR COMMENTS

NOTES __ Prototype hole is between the two existing holes__