

# SETUP SHEET RC10 B3

TEAM ASSOCIATED

OFFERT par [www.petitrc.fr.st](http://www.petitrc.fr.st)

driver QUERO Philippe  
 track / city Limoges  
 event 5 Roud French Champ. date 08/10/2000

## FRONT SUSPENSION

- 1 CASTER  25°  30°
- 2 FRONT RIDE HEIGHT  ARMS LEVEL  other \_\_\_\_\_
- 3 CAMBER - 2 °
- 4 ANTI ROLL BAR  NONE  
 THICK  
 THIN  
 other \_\_\_\_\_
- 5 TOE-IN 0 ° TOE-OUT 0 °
- 6 BUMP STEER SPACERS 0
- 7 STEERING ACKERMAN  STD  
 OPTIONAL

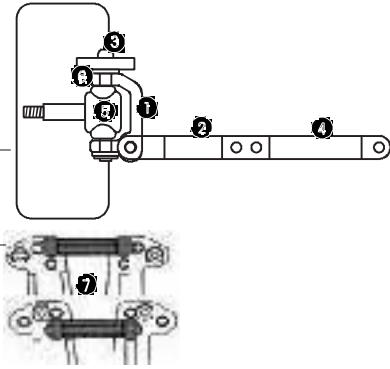

## FRONT SHOCKS

- BODY  STD  GRAY  other \_\_\_\_\_
- BODY  .89  other \_\_\_\_\_
- SHAFT  .71  other \_\_\_\_\_
- SHAFT  STD  Unobtainium

LIMITERS, inside 0  
 LIMITERS, outside 0

PISTON # 1  
 SPRING Green  
 OIL 20 wt

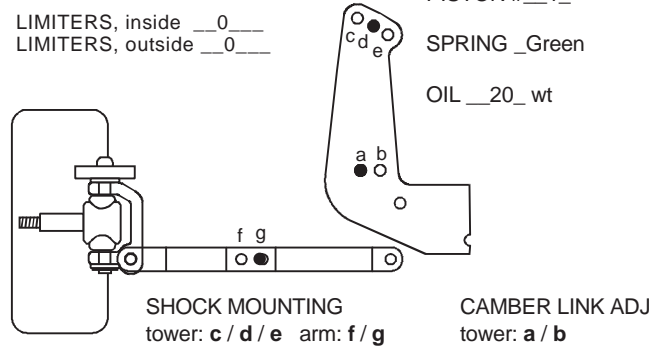

## REAR SUSPENSION

- 1 CAMBER - 2 °
- 2 REAR RIDE HEIGHT
- BONES LEVEL  other \_\_\_\_\_
- MIP CVD's  DOGBONES  UNIVERSALS
- 3 TOE-IN / ANTI-SQUAT  2-3  3-3  3-0 mount
- 4 ANTI ROLL BAR  NONE  
 THICK  
 THIN  
 other \_\_\_\_\_

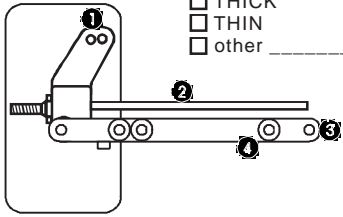

### WHEELBASE ADJUSTMENT

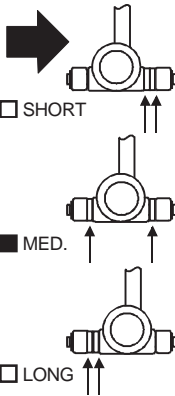

## REAR SHOCKS

- BODY  STD  GRAY  other \_\_\_\_\_
- BODY  1.32  other \_\_\_\_\_
- SHAFT  1.02  other \_\_\_\_\_
- SHAFT  STD  Unobtainium

LIMITERS, in 0.31  
 LIMITERS, out \_\_\_\_\_

PISTON # N°1  
 SPRING Green  
 OIL 20 wt

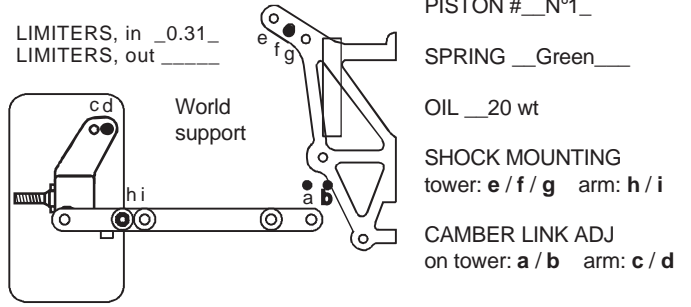

## OTHER

WEIGHT IN BULKHEAD 20 G  
 BODY \_\_\_\_\_  WING  
 FRONT TIRES ProLine 8015 M2 FOAM Std  
 REAR TIRES ProLine 8186 M2 FOAM Std  
 FRONT WHEELS  1 PC.  3 PC.  other \_\_\_\_\_  
 REAR WHEELS  1 PC.  3 PC.  other \_\_\_\_\_  
 CHASSIS  STD  SHORT  LONG  GRAPHITE

MOTOR NAME GM 10X2 Evo 3 PINION 21 T SPUR 84 T  
 BRUSHES GM SPRING GM

NOTES \_\_\_\_\_

SLIPPER  ASSOC.  HYDRA  VISCUOUS OIL \_\_\_\_\_

BATTERIES GM VIS 3000 PLACEMENT  FRONT  MIDDLE  REAR

RADIO M ZECH SPD. CONT. Cyclone SERVO KO 1001

## TRACK CONDITIONS

SURFACE  smooth  bumpy BUMPS: \_\_\_\_\_  
 TRACTION  low  med.  high  
 COMPOSITION  
 sandy  soft dirt  grass  clay  other \_\_\_\_\_  
 wet  dry  dusty  other \_\_\_\_\_  
 other: \_\_\_\_\_

## RACE COMMENTS

MAIN A PLACE 8  TQ

NOTES The only one RC 10 B3 placed in the A main

## CAR COMMENTS

NOTES i point works better in woops section: not used during Mains  
but was used during qualifications