

SETUP SHEET

RC10B3

TEAM ASSOCIATED

OFFERT par www.petitrc.fr.st

driver DEL COURT Jérôme

track / city Limoges

event 5 Roud French Champ. date 08/10/2000

FRONT SUSPENSION

- 1 CASTER 25° 30°
- 2 FRONT RIDE HEIGHT ARMS LEVEL other _____
- 3 CAMBER -1 °
- 4 ANTI ROLL BAR NONE
 THICK
 THIN
 other _____
- 5 TOE-IN 0 ° TOE-OUT 0 °
- 6 BUMP STEER SPACERS 0
- 7 STEERING ACKERMAN STD
 OPTIONAL

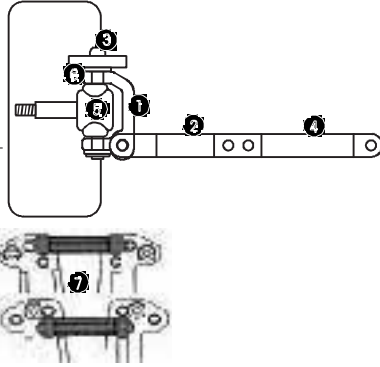

FRONT SHOCKS

- BODY STD GRAY other _____
- BODY .89 other _____
- SHAFT .71 other _____
- SHAFT STD Unobtainium

LIMITERS, inside 0
LIMITERS, outside 0

PISTON # 1

SPRING Green

OIL 20 wt

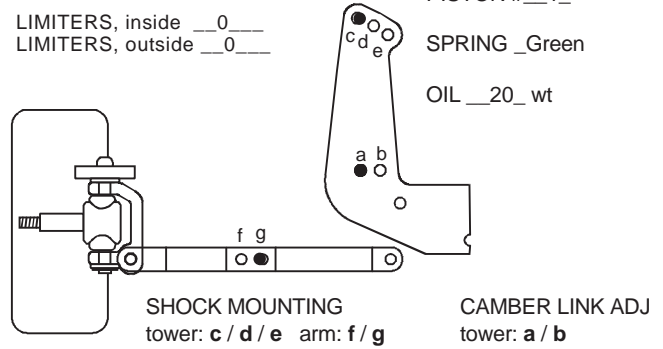

REAR SUSPENSION

- 1 CAMBER -2 °
- 2 REAR RIDE HEIGHT
- BONES LEVEL other _____
- MIP CVD's DOGBONES UNIVERSALS
- 3 TOE-IN / ANTI-SQUAT 2-3 3-1.5 3-0 mount
- 4 ANTI ROLL BAR NONE
 THICK
 THIN
 other _____

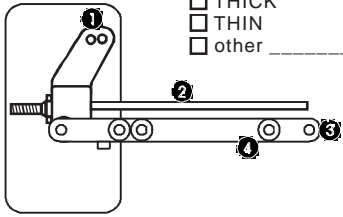

WHEELBASE ADJUSTMENT

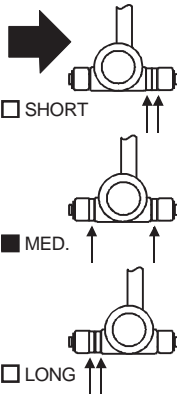

REAR SHOCKS

- BODY STD GRAY other _____
- BODY 1.32 other _____
- SHAFT 1.02 other _____
- SHAFT STD Unobtainium

LIMITERS, in 0
LIMITERS, out _____

PISTON # N°1

SPRING Silver

OIL 20 wt

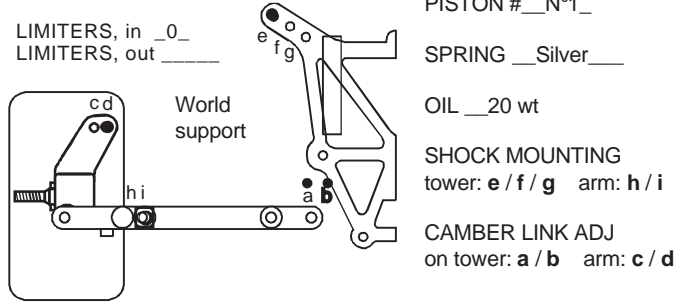

OTHER

WEIGHT IN BULKHEAD 20 G

BODY ProLine Deja Vu Tu

FRONT TIRES ProLine 8015 M2 FOAM Std

REAR TIRES ProLine 8186 M2 FOAM Std

FRONT WHEELS 1 PC. 3 PC. other _____ Wide

REAR WHEELS 1 PC. 3 PC. other _____ Wide

CHASSIS STD SHORT LONG GRAPHITE

MOTOR NAME Trinity 10 x 2 PINION 19 T SPUR 81 T

BRUSHES Reedy 737 X WING _____ SPRING Std

NOTES _____

SLIPPER ASSOC. HYDRA VISCUOUS OIL _____

BATTERIES Reedy Zappers 2000 PLACEMENT FRONT MIDDLE REAR

RADIO M ZECH SPD. CONT. Cyclone SERVO KO 2015

TRACK CONDITIONS

SURFACE smooth bumpy BUMPS: _____

TRACTION low med. high

COMPOSITION

sandy soft dirt grass clay other _____

wet dry dusty other _____

other: _____

RACE COMMENTS

MAIN B PLACE 5 TQ

NOTES The Jerome's come back !

CAR COMMENTS

NOTES _____