

SETUP SHEET RC10B3

TEAM ASSOCIATED

OFFERT par www.petitrc.fr

driver COULAZOU Bernard
 track / city Fleury Les Aubrais
 event French Champion's Cup date 18&19/11/2000

FRONT SUSPENSION

- 1 CASTER 25° 30°
- 2 FRONT RIDE HEIGHT ARMS LEVEL other Slightly_bellow arm level
- 3 CAMBER - 1 °
- 4 ANTI ROLL BAR NONE
 THICK
 THIN
 other _____
- 5 TOE-IN 0 ° TOE-OUT 1 °
- 6 BUMP STEER SPACERS 0
- 7 STEERING ACKERMAN STD
 OPTIONAL

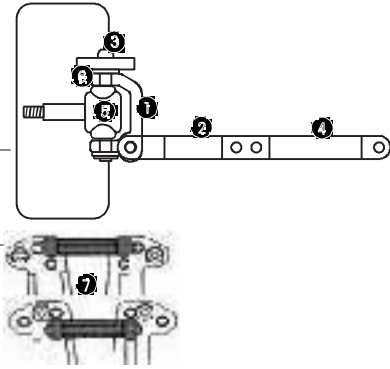

FRONT SHOCKS

- BODY STD GRAY other _____
- BODY .89 other _____
- SHAFT .71 other _____
- SHAFT STD Unobtainium

LIMITERS, inside 3 x 0.031
 LIMITERS, outside 0
 PISTON # 2
 SPRING Silver
 OIL 25 wt

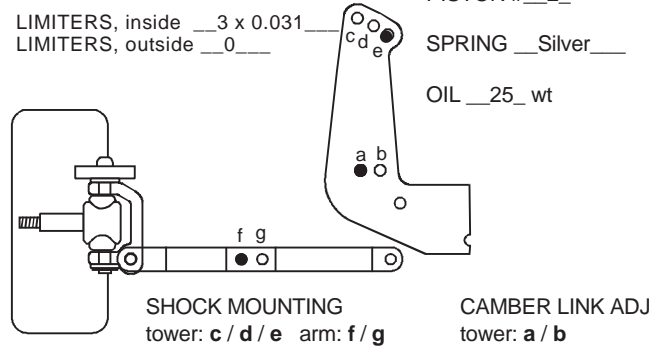

REAR SUSPENSION

- 1 CAMBER -1 °
- 2 REAR RIDE HEIGHT BONES LEVEL other _____
- MIP CVD's DOGBONES UNIVERSALS
- 3 TOE-IN / ANTI-SQUAT 2-3 3-4.5 3-0 mount
- 4 ANTI ROLL BAR NONE
 THICK
 THIN
 other _____

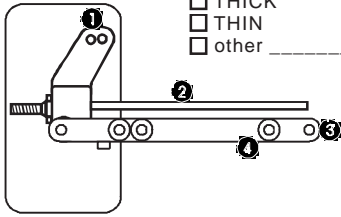

WHEELBASE ADJUSTMENT

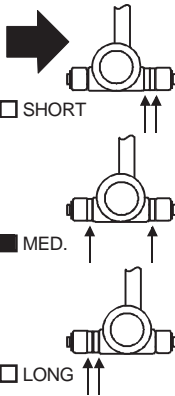

REAR SHOCKS

- BODY STD GRAY other _____
- BODY 1.32 other _____
- SHAFT 1.02 other _____
- SHAFT STD Unobtainium

LIMITERS, in 4 x 0.031
 LIMITERS, out _____
 PISTON # N°2
 SPRING SILVER
 OIL 25 wt

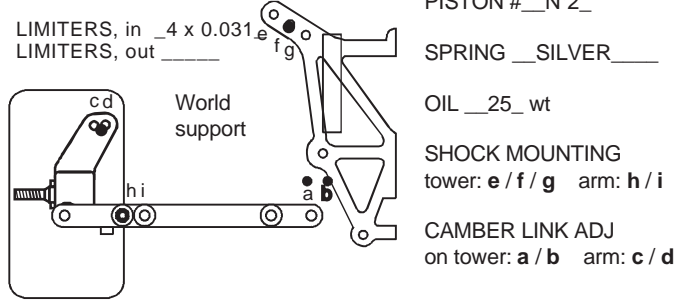

OTHER

WEIGHT IN BULKHEAD 20 Grs
 BODY Pro-Line Deja Vu Tu WING
 FRONT TIRES Mini Pin Yellow FOAM Yes
 REAR TIRES Mini Pin Yellow FOAM Yes
 FRONT WHEELS 1 PC. 3 PC. other _____
 REAR WHEELS 1 PC. 3 PC. other _____
 CHASSIS STD SHORT LONG GRAPHITE

MOTOR NAME Reedy Fury MW 11x3 PINION 19 SPUR 81_T
 BRUSHES Reedy 737 X SPRING STD

NOTES _____
 SLIPPER ASSOC. HYDRA VISCOUS OIL _____
 BATTERIES Reedy 3000_Sanyo PLACEMENT FRONT MIDDLE REAR
 RADIO Futaba SPD. CONT. LRP SERVO KO 2015

TRACK CONDITIONS

SURFACE smooth bumpy BUMPS: _____
 TRACTION low med. high
 COMPOSITION
 sandy soft dirt grass clay other Carpet
 wet dry dusty other _____
 other: _____

RACE COMMENTS

MAIN A PLACE 10 TQ

NOTES _____

CAR COMMENTS

NOTES _____