

1:10 SCALE OFF ROAD BUGGY MANUAL

RC10 B2



#9000 RACER KIT

#9011 SPORT KIT

RC10B2

WORLD CHAMPION



aa TEAM ASSOCIATED

RC10B2

Since its release, the RC10B2 has proven to be one of the most successful R/C off road cars on the market. The #9011 B2 Sport Kit is an inexpensive entry level version of our #9000 RC10B2 Racer Kit, and allows you to take advantage of our latest technology without the expense of our top of the line Racer ball bearing kit.

B2 FEATURES

Both kits feature our molded composite chassis and suspension parts, 2.40:1 Stealth transmission, adjustable battery position, new bell crank servo saver system, silicone shock oil, and pre bent wing wire. The new fine thread turnbuckles allow even more precise adjustment of the suspension parts.

The #9011 Sport Kit also comes with bronze bushings, gold anodized shocks and dog bones with stub axles. There is also a kit stock motor and mechanical speed control with forward and brakes (no reverse) included in the kit. The three piece wheels come with Pro-Line XTM compound Flat Four Rib front and Step Pin rear tires.

The #9000 Racer Kit comes with stainless steel ball bearings, hard anodized Teflon sealed shocks, and 3/16" diameter universal dog bone axles. The new rear axle design improves rear axle bearing life. The one piece wheels come with Pro-Line XTR compound Edge front and Flat Stubbie rear tires.

B2 CHASSIS

When we developed the B2 we started with a new molded composite chassis, designed to equal or exceed the strength and rigidity of our aluminum chassis. The overall weight of the chassis was reduced with this new design. The rear bulkhead was molded into the chassis, improving strength and reducing weight. We moved the suspension mounting points inboard for greater travel. The new suspension geometry gives you improved rough track performance and handling as well as greater on-power steering. The bolt-on aluminum nose and tail sections give us the added strength of aluminum at the suspension mounting points.

B2 POWER TRAIN

The B2 transmission was designed to lower the center of gravity of the power train components. The new, larger 2.40:1 differential delivers increased torque handling capacity and reduces the frequency of diff rebuilds. The new rear arms allow you to adjust the wheel base length for different steering and traction characteristics. You can do this now without having to change the rear suspension mounts. All of these changes were made for a lower center of gravity while still maintaining maximum suspension travel and chassis side clearance.

Now it's your turn to see what a World Championship car and Associated's years of experience can do for your racing.

TOOLS

KIT TOOLS SUPPLIED

- 1 Allen wrenches, .050", 1/16", 5/64", 3/32"
- 2 shock assembly tool
- 3 shock/turnbuckle wrench

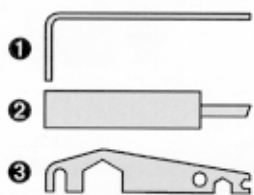

EXTRA TOOLS NEEDED

- 1 Phillips screwdrivers #1 and #2
- 2 flat blade screwdriver
- 3 needlenose pliers
- 4 soldering iron (40-50 watts) and a small amount of Rosin core solder. Pencil-type soldering iron is better than the gun type. **DANGER! Tip is HOT!**
- 5 Thread locking compound (#242 Blue Loctite® or equivalent)
- 6 super glue (cyanoacrylic glue)
- 7 hobby knife **WARNING! This knife cuts plastic and fingers with equal ease, so be careful.**
- 8 precision ruler

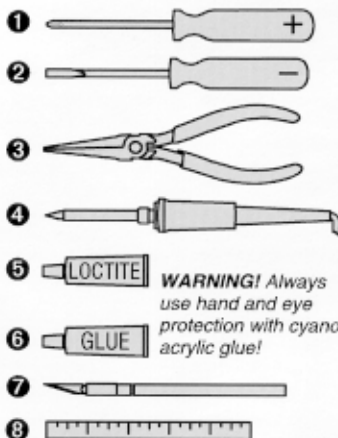

HELPFUL TOOLS (NOT REQUIRED)

- 1 Allen drivers (straight Allen wrenches with hex shaped handles) such as the following made by Associated:
#6957 .050" Allen wrench
#6958 1/16" Allen wrench
#6959 5/64" Allen wrench
#6960 3/32" Allen wrench
#6961 2.5mm Allen wrench
- 2 Hand drill with 1/8" & 1/4" bits

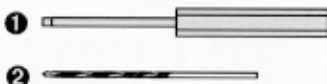

- 3 Vernier calipers
- 4 Hobby scissors
- 5 Liquid dish soap



- 6 Nut drivers (screwdriver-handled hex socket tools) such as the following from Associated:
#SP-86 3/16" nut driver
#SP-85 1/4" nut driver
#SP-82 11/32" nut driver



WARNING! Do not use a power screwdriver to install screws into nylon, plastic, or composite materials. The fast rotation speed can heat up the screws being installed. They can then break or strip the threads during installation.

ITEMS NEEDED TO OPERATE YOUR CAR

- 1 R/C two channel surface frequency radio system (#9000 requires only one servo & #9011 requires two servos). **WARNING!** The Futaba Attack radio system will not work as it comes from the factory due to insufficient servo travel. If you are going to use this radio system, you will need to contact Associated customer service for info on how to modify certain speed control parts.
- 2 *Battery pack (6 cell).
- 3 Battery charger (we recommend a peak detection charger).
- 4 *Electronic speed control (required for #9000 kit, optional for #9011 kit).
- 5 *R/C electric motor (included in #9011 kit).
- 6 *Pinion gear, 48 pitch size to be determined by type and wind of motor you will be using. (Included in #9011 kit).

* Available from Associated. See your B2 catalog.

REACHING US

CUSTOMER SUPPORT
(714) 850-9342
FAX (714) 850-1744

©1996 Associated Electrics, Inc.



ASSOCIATED ELECTRICS, INC.
3585 Cadillac Ave.
Costa Mesa, CA 92626
USA

BEFORE BUILDING

OPEN THE BAGS IN ORDER

The assembly is arranged so that you will open and finish that bag before you go on to the next bag. Sometimes you may have small parts remaining at the end of a bag. These will become part of the next bag. Some bags may have a large amount of small parts. To make it easier to find the parts we recommend the use of a partitioned paper plate for spreading out the parts so they will be easier to find.

MANUAL FORMAT

The following explains the new Associated format of these instructions.

The beginning of each section indicates:

- 1 Which bag to open ("**BAG A**").
- 2 Which parts you will use for those steps. Remove only the parts shown. "1:1" indicates an actual size drawing; place your part on top and compare it so it does not get confused with a similar part.
- 3 Which of the two kits the parts will be used for, and to which steps they apply ("**Remove these parts for: 9000:**"):

- 4 Which tools you should have handy for that section.
- 5 In some drawings, the word "**REAR**" with an arrow indicates which direction is the rear of the car to help keep you oriented.
- 6 The instructions in each step are ordered in the order you complete them, so read the words AND follow the pictures. The numbers in circles are also in the drawing to help you locate them faster.

SUPPLEMENTAL SHEETS

We are constantly developing new parts to improve our kits. These changes, if any, will be noted in supplementary sheets located in a parts bag or inside the kit box. Check the kit box before you start and each bag as it is opened. When a supplement is found attach it to the appropriate section of the manual.

Now clear off your workbench, line up some paper plates, grab your Big Gulp, triple decker BLT, candy bars, put out the dog, and let's begin!

BAG A

REMOVE THESE PARTS FOR:

9000: step 1

9011: step 1



6210, qty 2
front carrier block,
30° caster

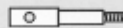

6220, qty 2
front axle



6221, qty 2
front steering block



6223, qty 2
kingpin

1:1



6272, qty 4
dust cover

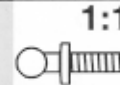

6273, qty 4
ball end



6299, qty 4
E-clip



6936, qty 4
#4 washer

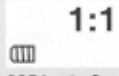

6951, qty 2
4-40 set screw

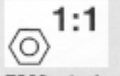

7260, qty 4
4-40 nut

TOOLS USED

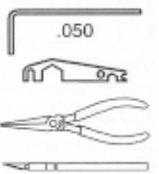

STEP 1 LEFT SIDE

ASSEMBLE #6221 FRONT STEERING BLOCKS

- 1 Assemble parts #6221, 6936, 6273, 7260, and 6272.
- 2 Push #6220 front axle into #6221 steering block, lining up holes.

ASSEMBLE #6210 CARRIER BLOCKS

- 3 Note location of L and R on carrier blocks for left and right blocks.
- 4 Assemble parts #6210, 6273, 7260, and 6272.

FINAL ASSEMBLY

- 5 Add one #6299 E-clip to #6223 kingpin.
- 6 Align #6221 steering block inside #6210 carrier block and insert #6223 kingpin through both.
- 7 Insert E-clip to other end of kingpin.
- 8 Add screw locking compound such as Loctite© (not included in kit) to #6951 set screw and tighten into #6220.
- 9 Now assemble right side.

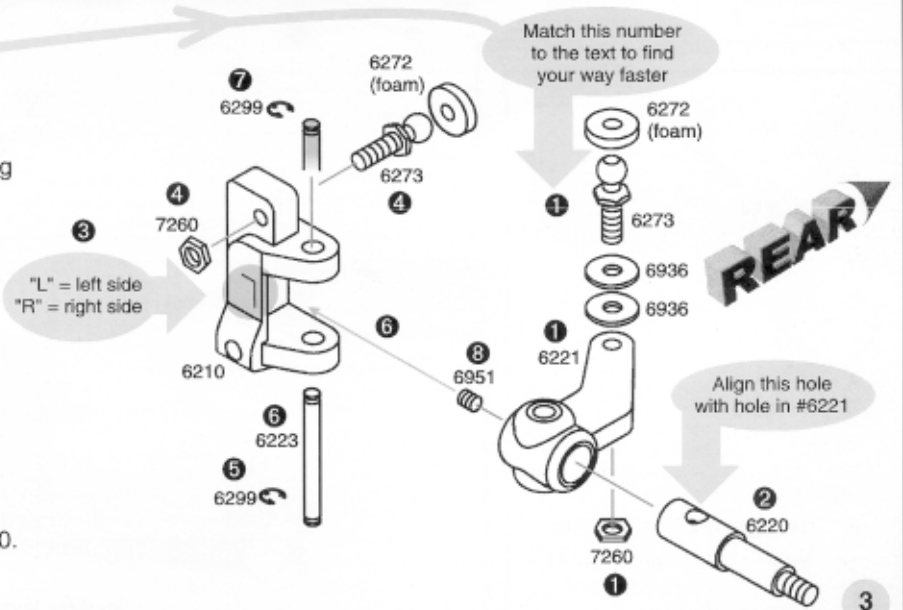

BAG A

REMOVE THESE PARTS FOR:

9000: step 2

9011: step 2

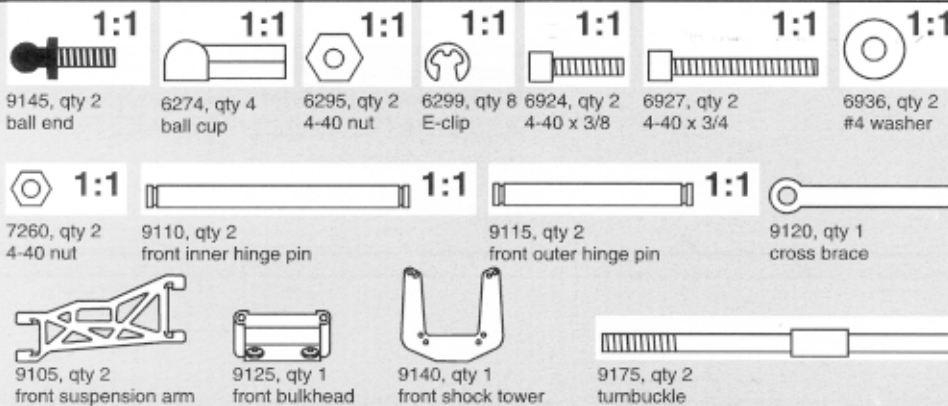

TOOLS USED

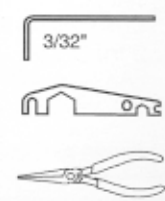

STEP 2 LEFT SIDE

ARMS TO BULKHEAD

- 1 Twist the #9105 suspension arms from the mold runners (shown in gray) with your pliers, and trim away the remaining molding with your hobby knife. Attach the carrier block assembly to the #9105 arm with its #9115 hinge pin and #6299 E-clips.
- 2 Hold the #9120 cross brace (shaded in drawing) against the bulkhead while you attach the #9105 suspension arm to the front bulkhead with its #9110 hinge pin and #6299 E-clips. Assemble the other side the same way.

SHOCK TOWER TO BULKHEAD

- 3 Attach the shock screws and hardware #6927, 6936, 6295.
- 4 Attach the #9145 ball ends and #7260 nuts.
- 5 Attach #9140 shock tower to the bulkhead with the two #6924 screws.
- 6 Twist #6274 ball cups onto the #9175 turnbuckle until you get the dimension shown. (Hold cups with needlenose pliers while screwing in turnbuckle with turnbuckle wrench around center portion.)
- 7 Connect ball ends with the turnbuckle ball cups as shown, using your needlenose pliers.

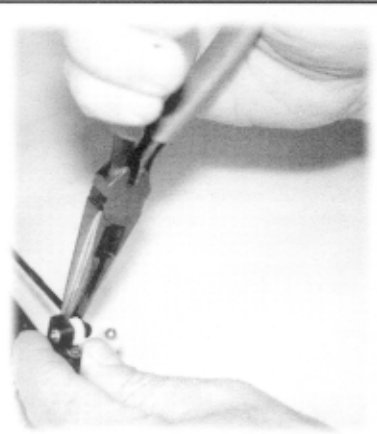
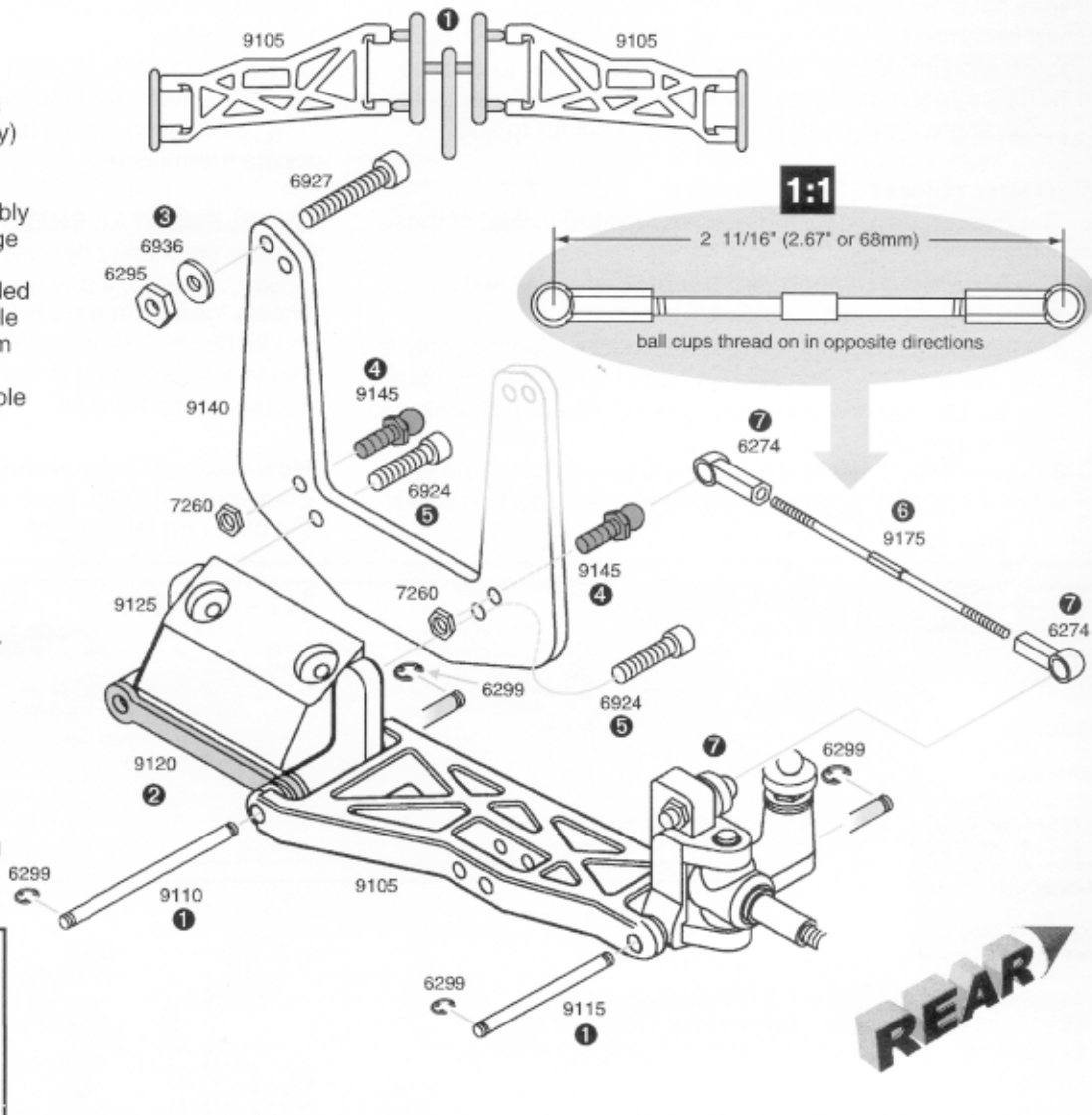

REMOVING BALL CUPS

Hold the cup next to the ball with your pliers and twist the cup off.

4

REAR SHOWN

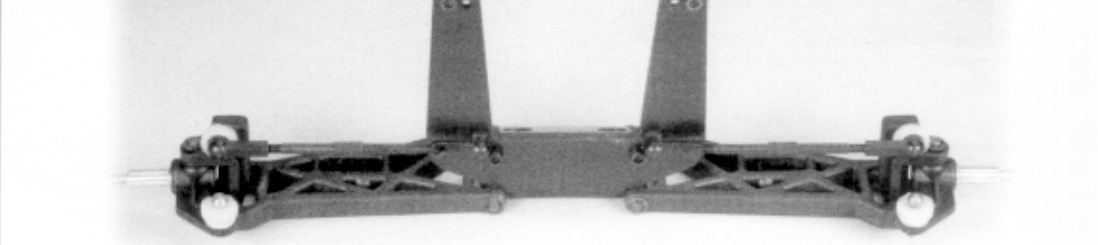

COMPLETED FRONT ASSEMBLY

BAG B

REMOVE THESE PARTS FOR:

9000: FIGS. 1-3

9011: FIGS. 1-3

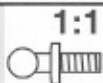

6270, qty 5
ball end



6272, qty 5
dust cover

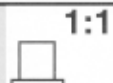

9155, qty 2
left hand servo
saver bushing



9155, qty 1
servo saver arm

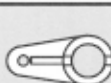

9155, qty 1
servo saver arm

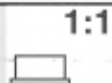

9155, qty 2
bell crank
bushing

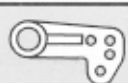

9155, qty 1
bell crank

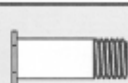

9156, qty 1
tube,
aluminum

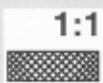

9157, qty 1
adjusting nut

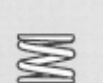

9157, qty 1
servo saver
spring

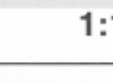

9160, qty 1
mounting pin,
right hand

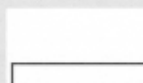

9160, qty 1
mounting pin,
left hand



9165, qty 1
drag link



9210, qty 1
kickup

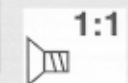

9215, qty 3
6-32 x 3/16

TOOLS USED

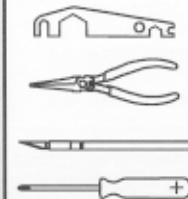

STEP 1

KICKUP TO CHASSIS

1 Add screw locking compound such as Loctite® (not included in kit) to the three #9215 screws and attach the #9210 aluminum kickup (nose plate) to the #9200 chassis.

2 Place the two #9160 servo saver/bell crank mounting pins in the locating holes.

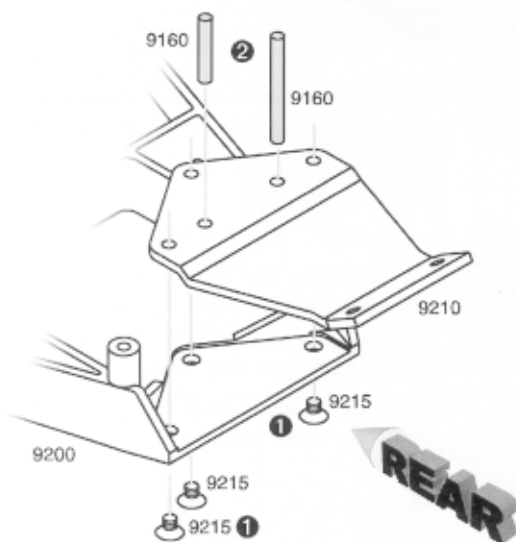

STEP 2

SERVO SAVER

1 Push one #9155 bushing into each end of the #9156 aluminum tube.

2 Slide the two #9155 servo saver arms onto the tube.

3 Slide the spring and adjusting nut on the tube. Tighten the nut until 1/32" of the tube threads are exposed.

4 Add three #6270 ball ends where shown and three #6272 foam dust covers onto them.

BELLCRANK

5 Install the two #9155 bushings into the bell crank.

6 Add two #6270 ball ends where shown and two #6272 foam dust covers onto them.

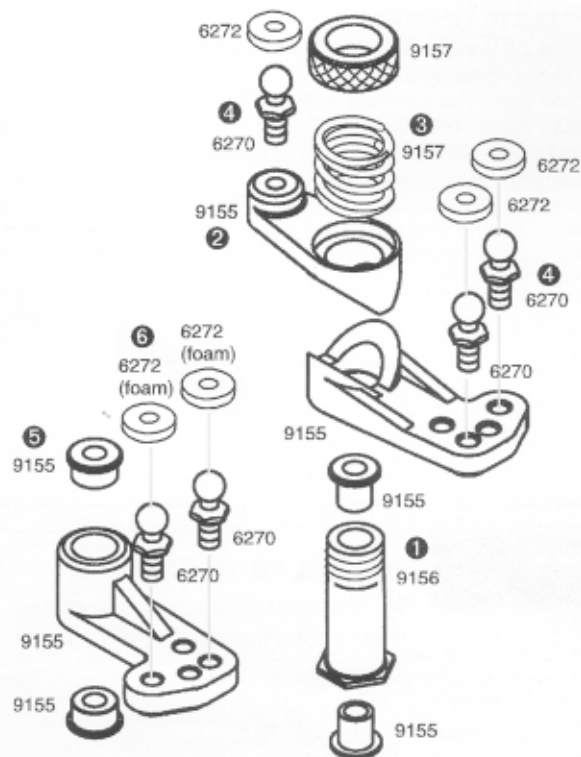

STEP 3

DRAG LINK

1 Install the #9165 drag link over the two ball ends with your needlenose pliers.

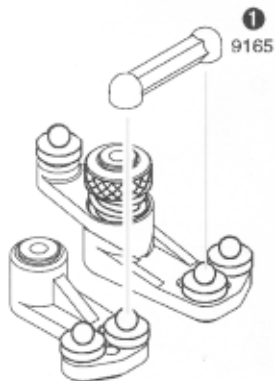

PROFILE

MATT FRANCIS

Matt Francis Top Qualified and won the 1995/1996 2WD World Championships held at Yatabe Arena in Tsukuba City, Japan, with his RC10B2.



BAG B

REMOVE THESE PARTS FOR:

#9000: FIGS. 4-6

#9011: FIGS. 4-6

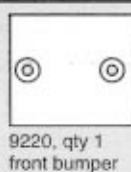
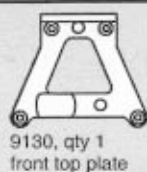
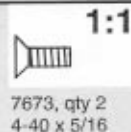
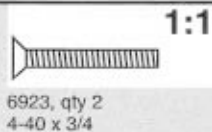

TOOLS USED

1/16"

STEP 4

SERVO SAVER TO CHASSIS

① Place the servo saver assembly over the pins.

TOP PLATE TO CHASSIS

② Line up the #9130 front top plate with the servo saver pins and screw holes.

③ Bolt down the top plate with two #6923 screws tightly, then back off both screws one full turn. This will allow us to accomplish step 5 below.

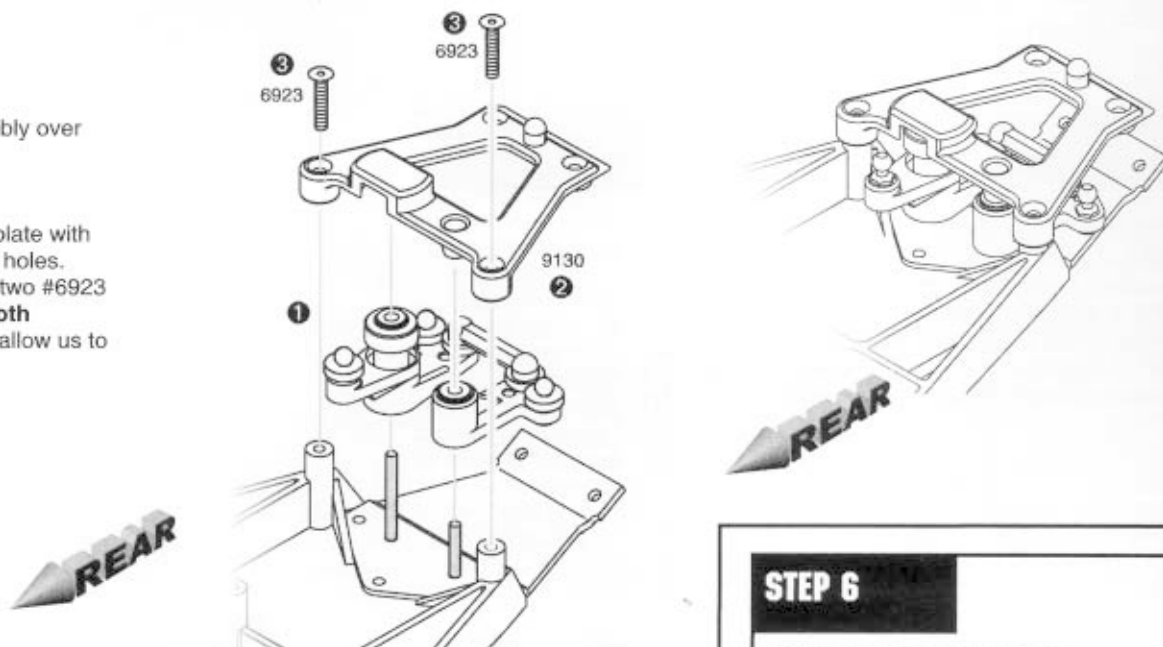

STEP 5

FRONT END TO CHASSIS

① Slip front end under top plate, then push rearward over kickup.

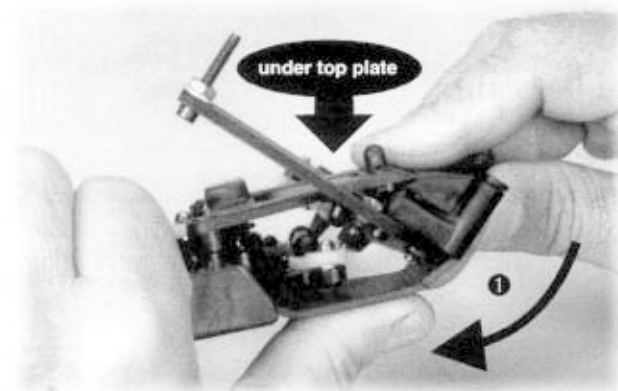

REAR



6

STEP 6

BUMPER TO CHASSIS

① Add four #6292 screws to secure the front end assembly.
② Go back and tighten the two #6923 screws from Bag B, step 4.
③ Bolt on the #9220 bumper with the two #7673 screws.

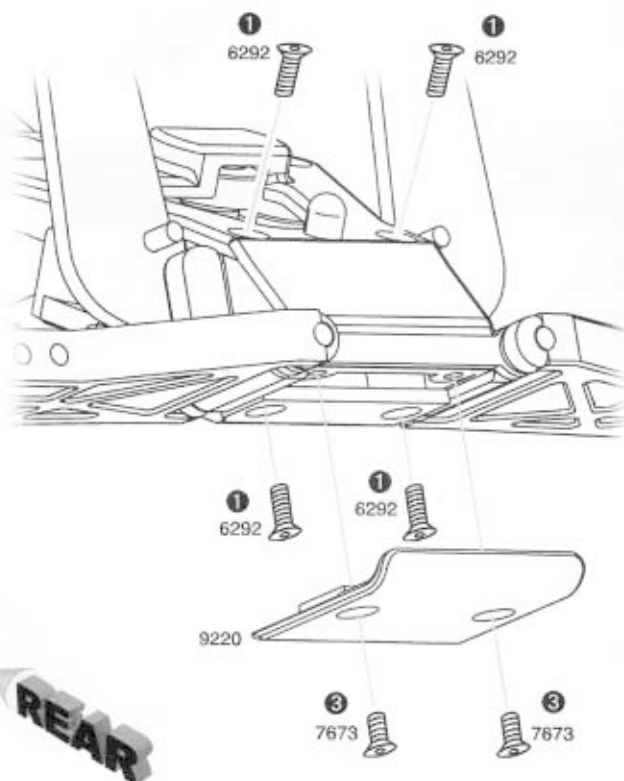

BAG B

REMOVE THESE PARTS FOR:

9000: FIG. 7

9011: FIG. 7



6274, qty 4
ball cup

1:1



8437, qty 2
turnbuckle

1:1

TOOLS USED

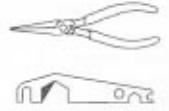

STEP 7

TURNBUCKLES

- 1 Add #6274 ball cups to two #8437 turnbuckles to the dimension shown.
- 2 Pop on the turnbuckles. Do both sides.

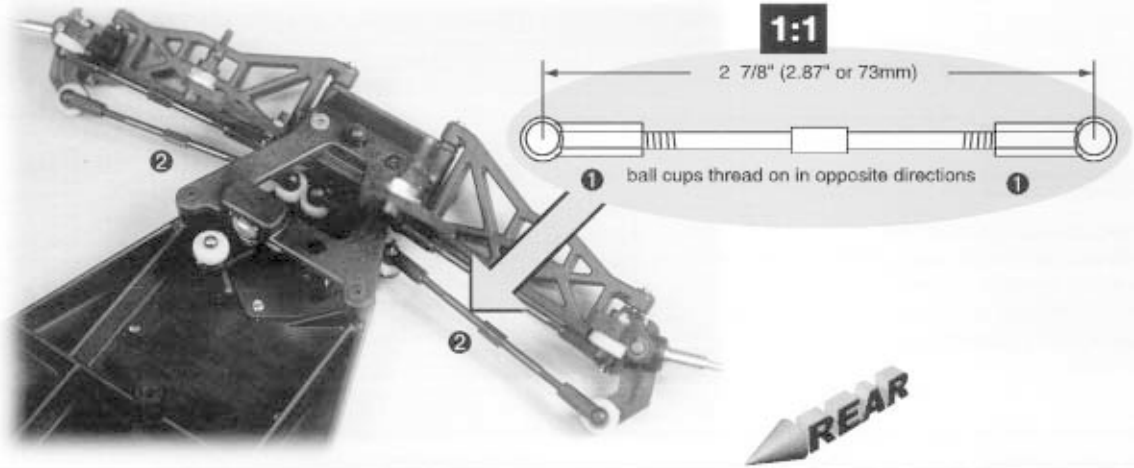

PROFILE



YATABE ARENA

On this track in Tsukuba, Japan, Matt Francis finished either 1st, 2nd, or 3rd in every one of the six qualifying rounds on his way to taking Top Qualifier honors. Then he won the first two A-Mains in a runaway to win the World Championships.

BAG C

REMOVE THESE PARTS FOR:

9000: steps 1-3

9011: steps 1-3

1:1 4449, qty 2 4-40 locknut	1:1 6272, qty 2 dust cover	1:1 6273, qty 2 ball end	1:1 6292, qty 4 4-40 x 3/8	1:1 6299, qty 2 E-clip	1:1 6922, qty 4 4-40 x 1/2
9240, qty 1 rear chassis plate	9255, qty 2 suspension arm	9260, qty 2 rear inner hinge pin	9265, qty 2 3" rear suspension mount		

TOOLS USED

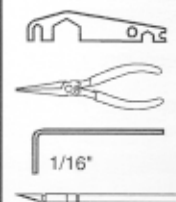

STEP 1

TRIM SUSPENSION ARMS

1 Twist the #9105 suspension arms from the mold runners (shown in gray) with your pliers, and trim away the remaining molding with your hobby knife.

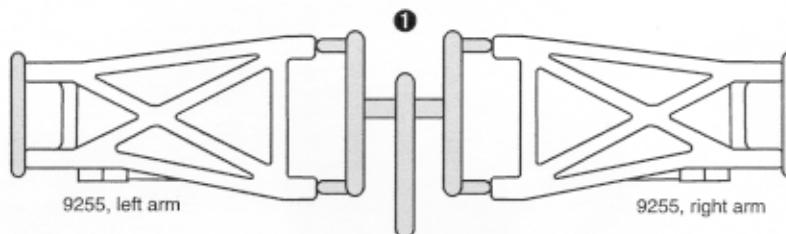

STEP 2 LEFT SIDE

REAR PLATE TO CHASSIS

- 1 Attach the two #9265 suspension mounts to the #9240 chassis plate with two #6922 screws each. The mounts are marked "L3" for the left side and "R3" for the right side.
- 2 Fasten the chassis plate to the bottom of the chassis with four #6292 screws.
- 3 Add two #6273 ball ends to the inside holes of the chassis, then thread on the #4449 nuts to the ball ends. Then add the #6272 foam dust covers.

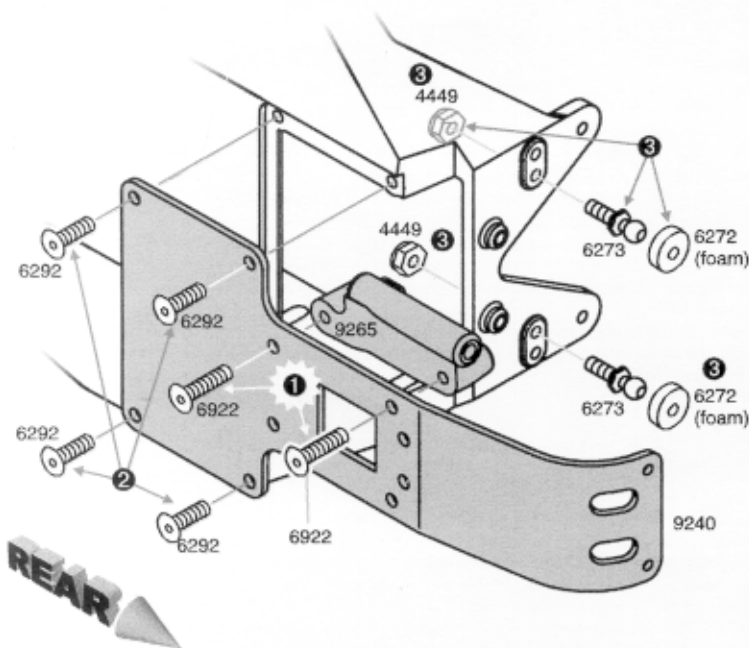

STEP 3 LEFT SIDE

SUSPENSION ARMS TO MOUNTS

- 1 Attach the #9255 left suspension arm to the #9265 left mount with the #9260 hinge pin and #6299 E-clips.
- 2 Now do the right side.

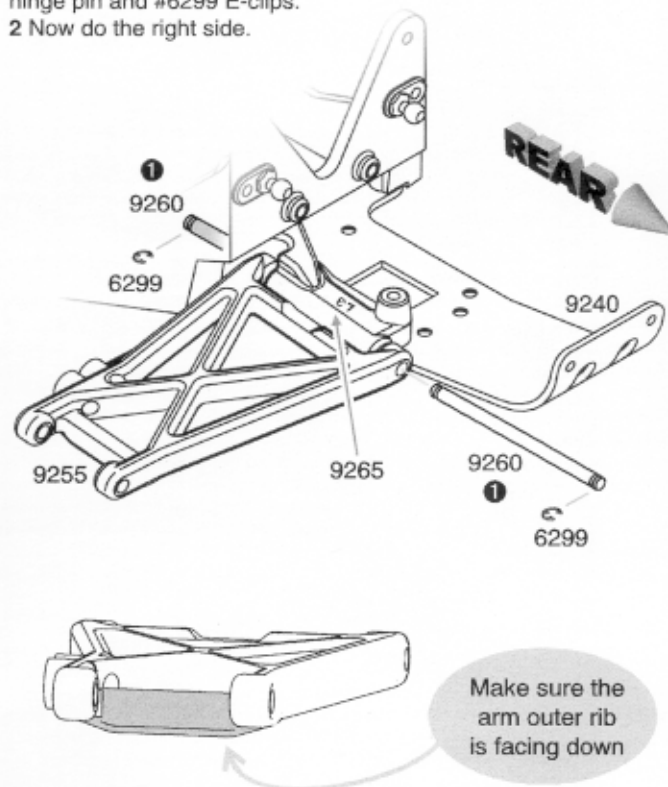

BAG D

REMOVE THESE PARTS FOR:

9000: steps 1-4

9011: steps 1-4

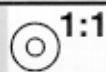

6573, qty 2
diff thrust
washer



6574, qty 6
diff thrust
ball



6575, qty 1
T-nut



6575, qty 1
diff thrust bolt
cover, nylon



6575, qty 1
2-56 diff bolt



6581, qty 12
diff balls
carbide

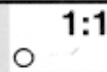

6582, qty 1
diff spring



6582, qty 1
diff spring

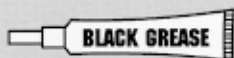

6588, qty 1
black grease

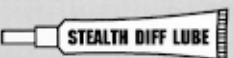

6591, qty 1
diff lube



9365, qty 1
diff gear



9367, qty 2
diff drive ring

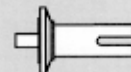

9370, qty 1
left diff
outrdrive hub



9375, qty 1
right diff
outrdrive hub

TOOLS USED

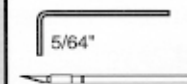

STEP 1

SET UP DIFF GEAR

- 1 Add a generous amount of #6591 diff lube to the #9365 diff gear ball holes and push in the twelve #6581 diff balls. Then push back in the lube that came out.
- 2 Insert one #6597 bushing or #6589 bearing into the gear.

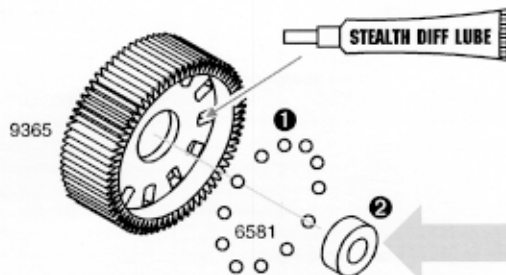

#9000 ONLY



6589, qty 1
5/32 x 5/16
ball bearing

#9011 ONLY

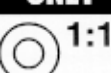

6597, qty 1
5/32 x 5/16
bushing

STEP 2

LEFT OUTDRIVE HUB

Push in the #6582 spring and #6575 T-nut.

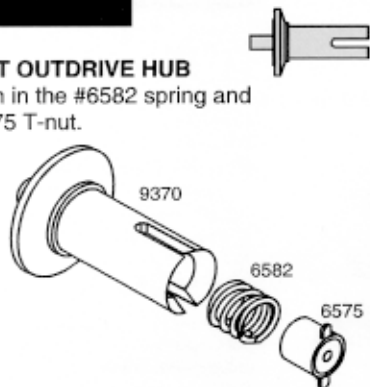

STEP 3

RIGHT OUTDRIVE HUB

- 1 Slide one #6573 washer onto the #6575 bolt. Apply a generous amount of #6588 black grease to the washer on the side facing away from the bolt head.
- 2 Stick six #6574 balls into the grease against the #6575 bolt and washer. Add the other #6575 washer. The grease will hold the balls in place during assembly.
- 3 Slide all this into the #9375 right outrdrive hub, being careful not to lose any of the balls.
- 4 Insert the #6575 bolt cover.

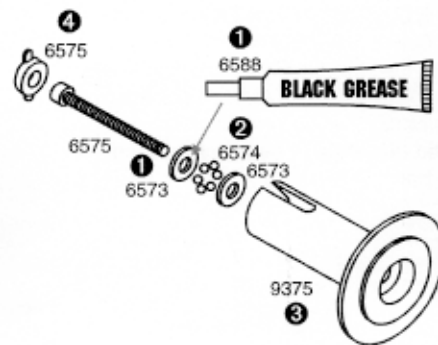

STEP 4

RIGHT OUTDRIVE HUB

- 1 Insert one #6597 bushing or #6589 bearing into the #9375 right hub.
- 2 Add a **light** coat of #6591 diff lube to right hub where shown.
- 3 Place a #9367 diff drive ring and then the gear assembly on the hub.

ASSEMBLE THE HUBS

- 4 Add **light** coat of #6591 diff lube to left hub where shown.
- 5 Place a #9367 diff drive ring on the hub.
- 6 Push the #9370 hub over the diff bolt and center the hub.

CHECK ALIGNMENT OF HUBS

- 7 Tighten the diff with your 5/64" Allen wrench, but not completely.
- 8 Rotate the diff hubs several times as you are tightening the bolt to check for proper alignment of the parts.
- 9 We'll adjust the diff on the next page.

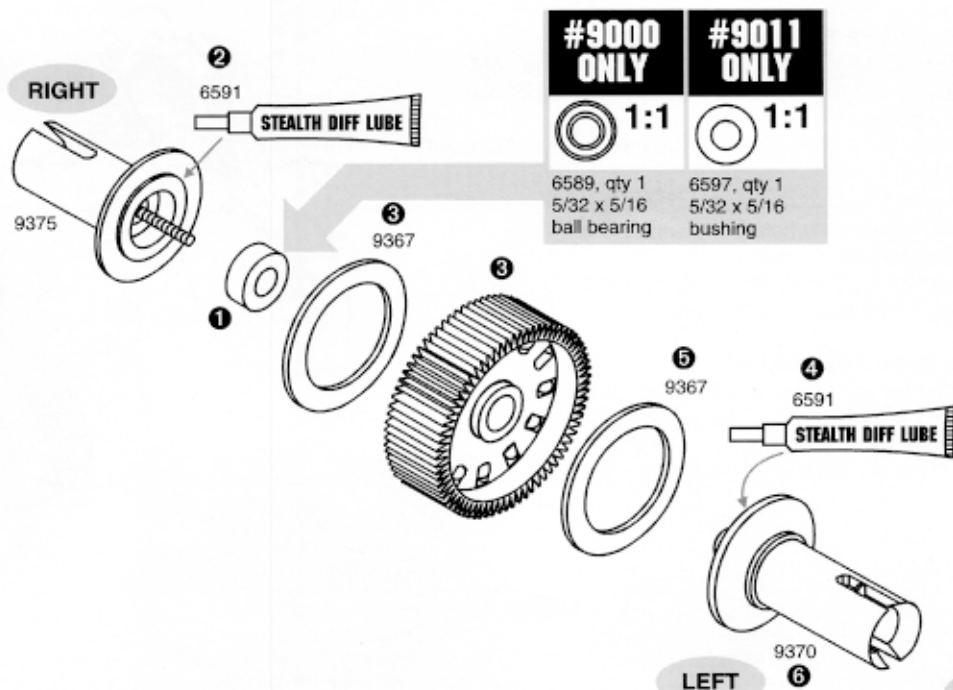

#9000 ONLY



6589, qty 1
5/32 x 5/16
ball bearing

#9011 ONLY



6597, qty 1
5/32 x 5/16
bushing

STEP 5

ADJUST THE DIFFERENTIAL

1 As you tighten the diff bolt, you will notice the T-nut ears moving closer to the bottom of the diff hub slot. This compresses the spring behind the T-nut. The spring should be fully compressed at the same time the T-nut reaches the end of the slot. **Caution:** Pay close attention to feeling when

the spring is fully compressed. **Do not overtighten the bolt.** When you feel the spring fully compressed, loosen the diff bolt 1/8 of a turn. No more, no less. Your diff should now operate very smoothly when turning the hubs in opposite directions. After you have driven the car once, recheck the diff adjustment. Never adjust the diff any other way.

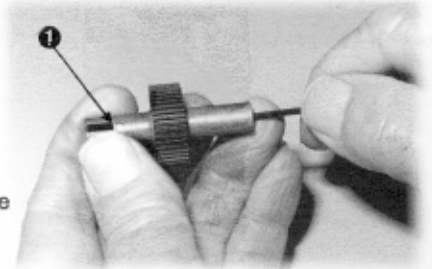

BAG D

REMOVE THESE PARTS FOR:

9000: steps 6-7

9011: steps 6-7



6292, qty 1
4-40 x 3/8

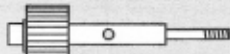

6571, qty 1
drive shaft/gear



6572, qty 1
drive shaft
roll pin



6928, qty 3
4-40 x 1



7669, qty 2
drive shaft
spacer



9352, qty 1
right tranny case



9352, qty 1
left tranny case



9360, qty 1
idler gear



9361, qty 1
idler gear shaft

TOOLS USED

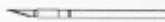
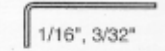

STEP 6

ADD BUSHINGS OR BEARINGS TO THE CASE HALVES

- 1 Cut the two #9352 transmission case halves and the three #9352 spacers from the runner.
- 2 Add bushings or bearings to each case half.

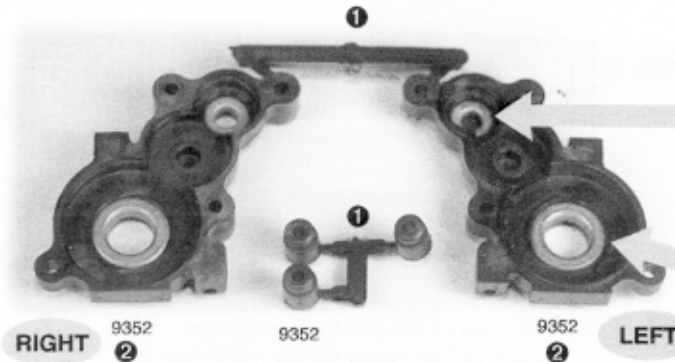

#9000 ONLY



6906, qty 2
3/16 x 3/8
unflanged bearing



6903, qty 2
3/8 x 5/8
unflanged bearing

#9011 ONLY



6599, qty 2
3/16 x 3/8
bushing

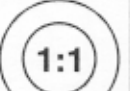

6598, qty 2
3/8 x 5/8
bushing

STEP 7

INSIDE THE TRANNNY

- 1 Install the right side diff assembly into the right case. (Page 9, Step 3 will show you which diff hub is the right side.)
- 2 Add the #7669 spacer to the #6571 drive shaft and put both into the case.
- 3 Install the two bushings or bearings in the #9360 gear, followed by the #9361 shaft. Insert the assembly into the case.
- 4 Add the other #7669 spacer to the #6571 shaft and put the case halves together.

OUTSIDE THE TRANNNY

- 5 Screw the halves together with one #6292 bolt.
- 6 Insert the #6572 roll pin into the shaft hole with your needlenose pliers.
- 7 Push the three #6928 bolts through.

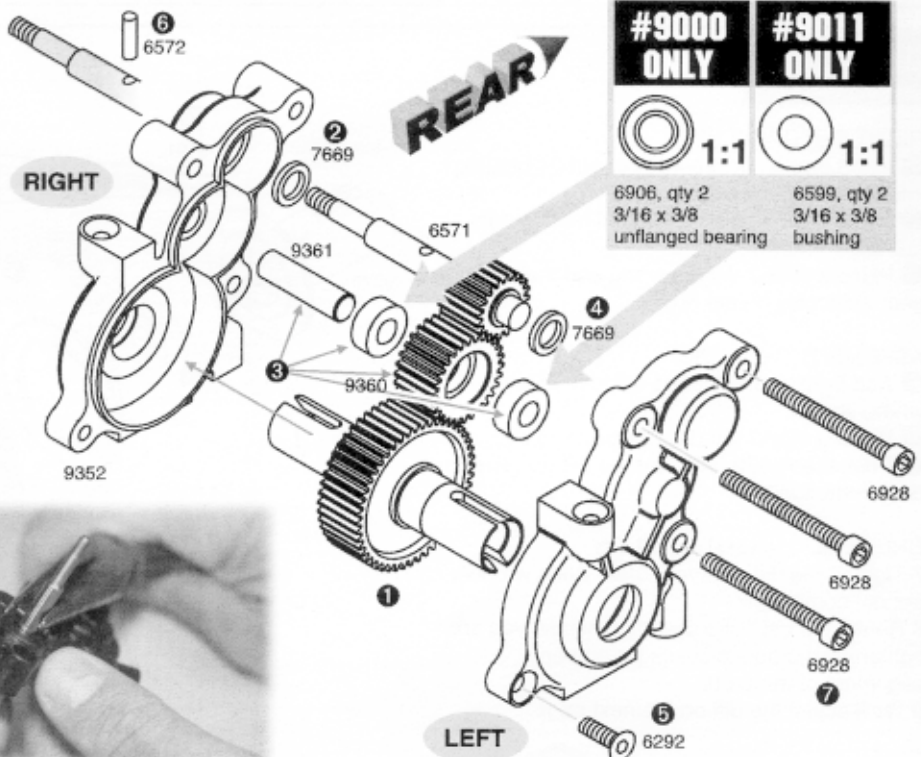

#9000 ONLY



6906, qty 2
3/16 x 3/8
unflanged bearing

#9011 ONLY



6599, qty 2
3/16 x 3/8
bushing

center pin about shaft

BAG D

REMOVE THESE PARTS FOR:

9000: steps 8-11

9011: steps 8-11

1:1



6292, qty 2
4-40 x 3/8

1:1



6568, qty 4
4-40 x 3/16

1:1



9352, qty 3
motor plate
spacer



6583, qty 1
inner torque
clutch hub



6584, qty 1
outer torque
clutch hub



6585, qty 1
Rulon disc

1:1



6587, qty 1
torque control
spring

1:1



6594, qty 2
thrust bearing
washer (thin)

TOOLS USED

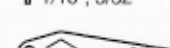

1:1



6594, qty 1
thrust bearing
(thick gold)

1:1



6596, qty 1
3/16 x 5/16
bushing

1:1



6629, qty 1
5-40

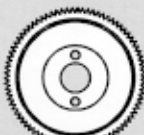

6693, qty 1
81T 48 pitch
Stealth spur gear

1:1



7373, qty 1
motor plate gasket
foam

1:1



7874, qty 2
4-40 x 7/16



9245, qty 1
motor plate

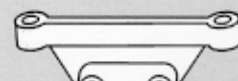

9380, qty 1
rear transmission
brace

STEP 8

REMOVE THE BACKING

1 Remove the backing and center from the #7373 gasket.

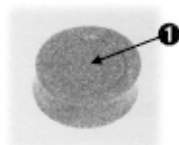

STEP 9

INSTALL THE MOTOR PLATE

1 Center the #7373 gasket around the large round hole of the plate.
2 Install the three #9352 spacers.
3 Line up the #9245 plate and fasten with three #6928 screws.

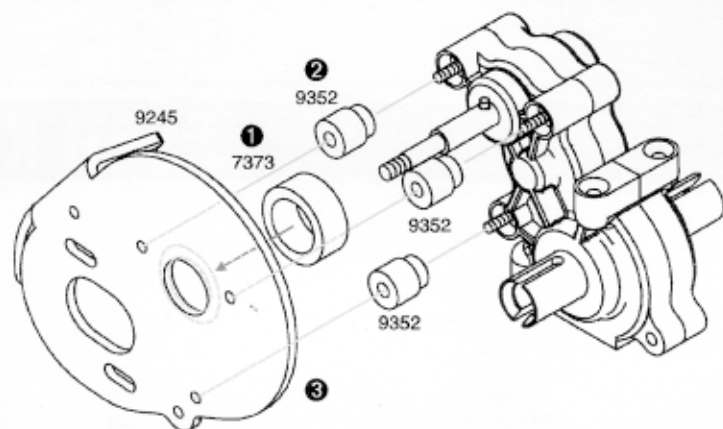

STEP 10

INSTALL THE ASSOCIATED TORQUE CLUTCH (ATC)

1 Add the #6583 to the shaft, lining up the notch with the roll pin.
2 Install the #6596 bushing into one side of the #6584 hub and the #6585 disc on the other side. Push onto the shaft.
3 Install parts in the following order: #6594 (thin), 6594 (thick), 6594 (thin), 6587 black spring, 6629 locknut.
4 Orient the #6693 spur gear side facing out as shown and mount with two #6568 screws.
5 Tighten the #6629 locknut so the end of the shaft is flush with the end of the nut.

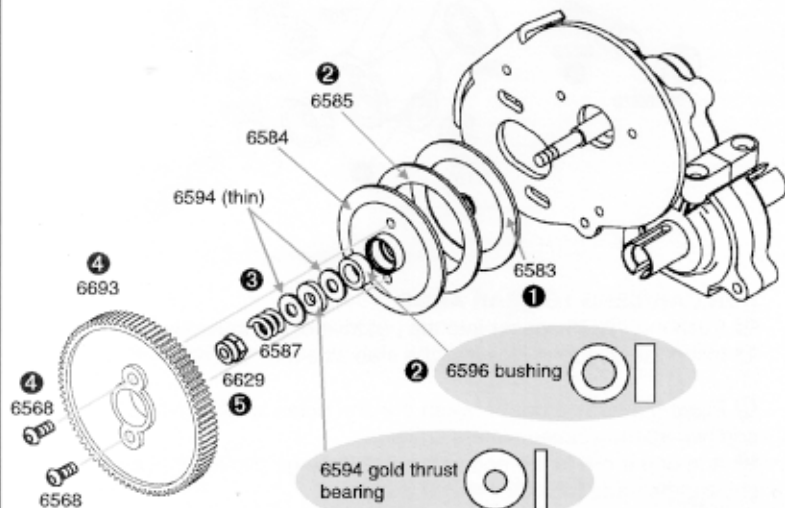

STEP 11 LEFT SIDE

MOUNT THE TRANSMISSION

1 Mount the #9380 brace with two #7874 screws.
2 Mount the tranny with the two #6292 screws from below, lining up the motor plate holes as shown.
3 Bolt the brace to the plate with two #6568 screws.

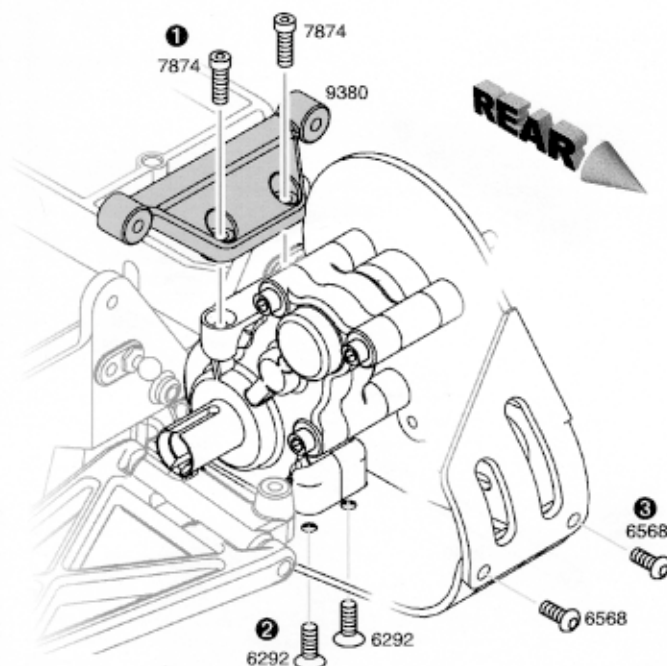

#9011 KIT ONLY

BAG E

REMOVE THESE PARTS FOR:

9011: step 1

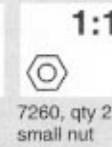
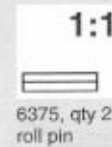
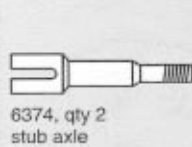
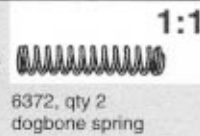
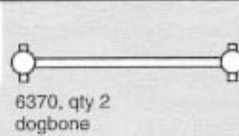
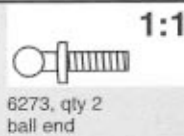

TOOLS USED

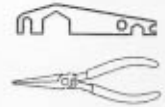

STEP 1 LEFT SIDE

#9011 KIT ONLY

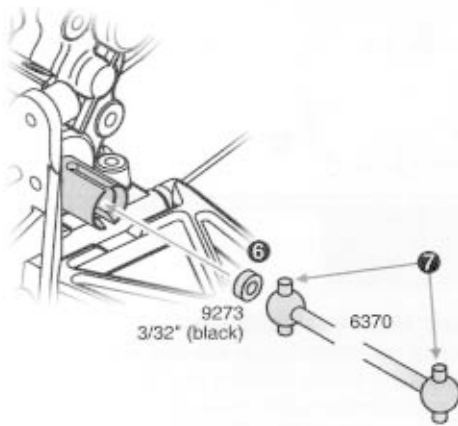

ASSEMBLE REAR HUB CARRIERS

- 1 Insert #7360 bushings into each side of carrier. Install the #6374 stub axle as shown.
- 2 Insert #6388 cone washer as shown, raised outer edges facing out. Add #6375 roll pin.
- 3 Insert the #6372 spring into the stub axle.
- 4 Thread on the #6273 ball end and add the #7260 nut to the other side. (When you do the other hub carrier, thread the ball end into the other side so both will point to the front when assembled.) Add a #6272 dust cover to the ball end.
- 5 Follow the above for the second hub carrier.

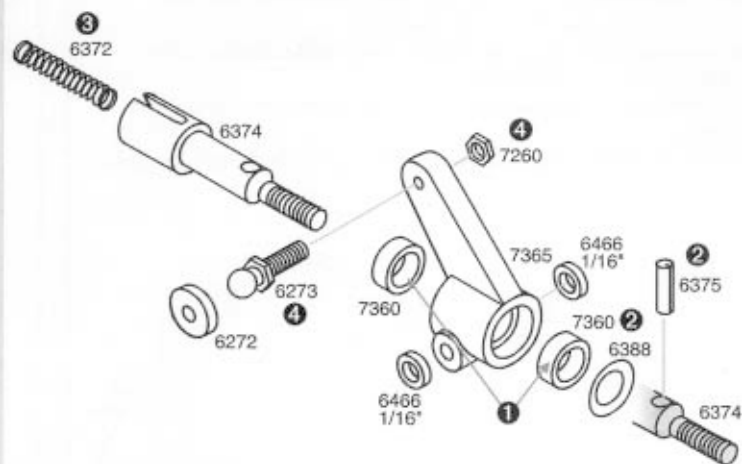

HUB CARRIERS TO REAR ARMS

- 6 Push the #9273 spacer into the outdrive of the transmission.
- 7 Insert the dogbone pins into the stub axle and outdrive hub as shown.
- 8 Place the hub carrier between the arm holes as shown and add two #6466 spacers where shown.
- 9 Add one e-clip to the end of the #9263 hinge pin, insert it as shown, then add the other #6299 E-clip.
- 10 Now install the axle assembly for the other side.

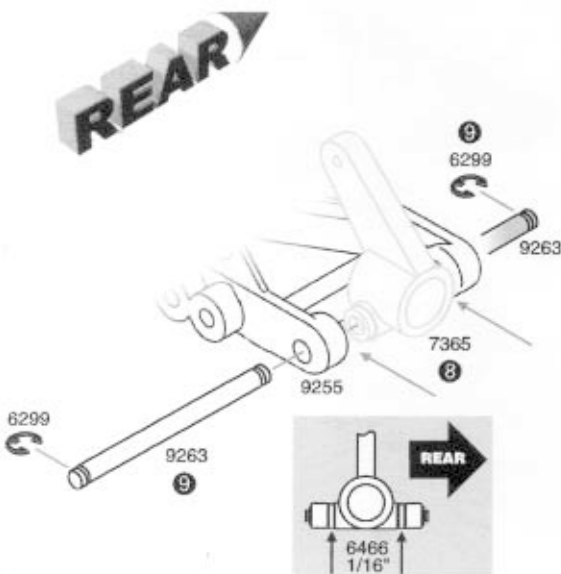

#9000 KIT ONLY

BAG E

REMOVE THESE PARTS FOR:

9000: step 1

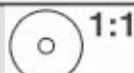

6272, qty 2
dust cover



6273, qty 2
ball end

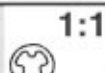

6299, qty 4
E-clip



6466, qty 4
spacer, 1/16"



6906, qty 4
3/16 x 3/8
ball bearing



7260, qty 2
small nut



7365, qty 2
hub carrier



7377, qty 2
rear axle
bearing spacer



7368, qty 12
universal shims



7369, qty 2
axle spring
pins



9263, qty 2
rear outer hinge pin

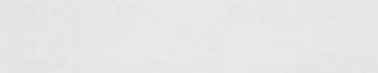

9275, qty 2

TOOLS USED

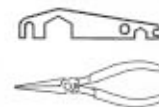

STEP 1 LEFT SIDE

#9000 KIT ONLY

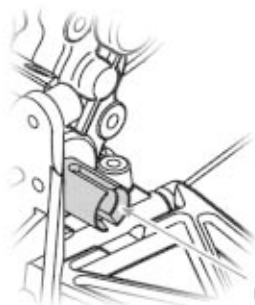

REAR

ASSEMBLE REAR HUB CARRIERS

- 1 Insert a #6906 bearing into the rear of the hub carrier. Add three #7368 shims to the #9275 as shown. Insert axle into hub carrier.
- 2 Insert one #7377 spacer, one #6906 bearing, and three #7368 shims into hub carrier onto axle. Add #7369 roll pin to axle.
- 3 Thread on the #6273 ball end and add the #7260 nut to the other side. (When you do the other hub carrier, thread the ball end into the other side so both will point to the front when assembled.) Add a #6272 dust cover to the ball end.
- 4 Follow the above for the second hub carrier.

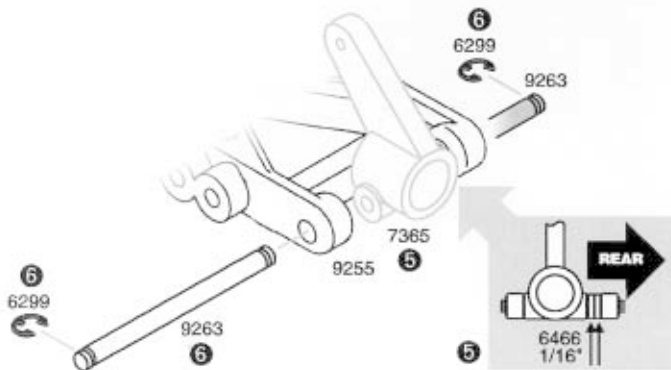
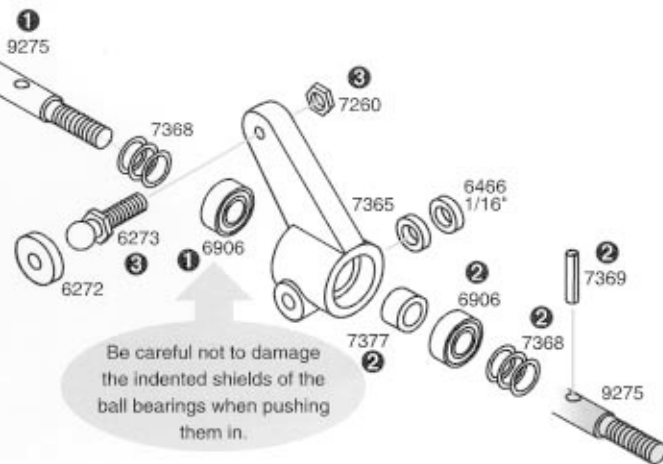

HUB CARRIERS TO REAR ARMS

- 5 Place the hub carrier between the arm holes as shown and add two #6466 spacers where shown.
- 6 Add a #6299 E-clip to the #9263 hinge pin insert it as shown, then add an E-clip at the other end of the hinge pin.
- 7 Insert the universal dog bone into the slots of the outdrive hub.
- 8 Now install the axle assembly for the other side.

#9000 & #9011 KITS

BAG E

REMOVE THESE PARTS FOR:

9000: step 2

9011: step 2

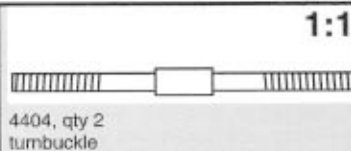

4404, qty 2
tumbuckle



6274, qty 4
ball cup

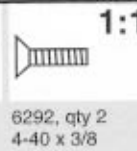

6292, qty 2
4-40 x 3/8

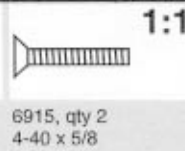

6915, qty 2
4-40 x 5/8

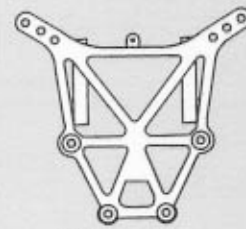

9270, qty 1
rear shock strut

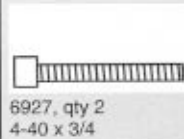

6927, qty 2
4-40 x 3/4



7260, qty 2
4-40 nut

TOOLS USED

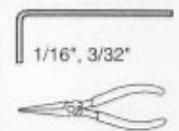

STEP 2 LEFT SIDE

MOUNT THE REAR SHOCK TOWER

- 1 Orient the tower outward as shown and mount to bulkhead with #6292 screws.
- 2 Fasten the tower to the transmission brace with the #6915 screws.
- 3 Add two #6927 screws in the middle holes at top, then thread on #7260 nuts.

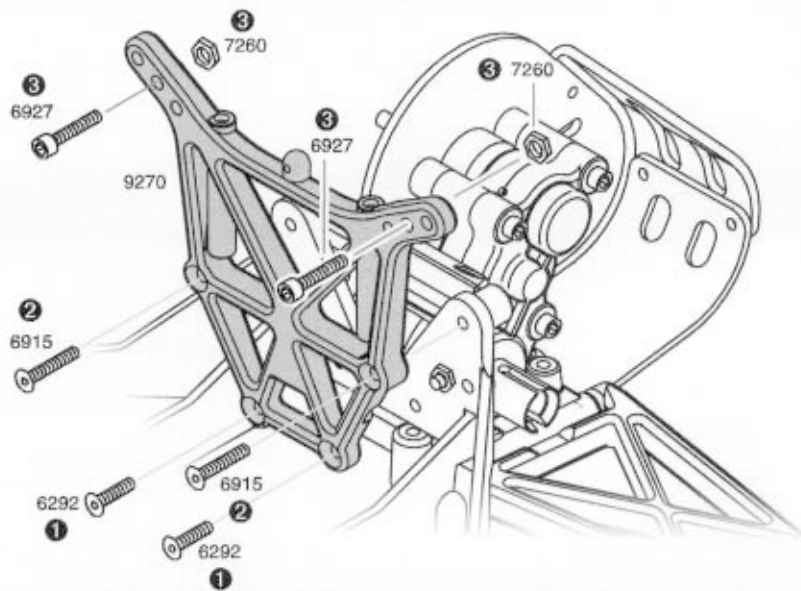

STEP 3 REAR VIEW

COMPLETED REAR ASSEMBLY

ADD TURNBUCKLES

- 1 Twist #6274 ball cups onto the #4404 tumbuckle until you get the dimension shown. **Ball cups will face in opposite directions.**
- 2 Connect ball ends with the tumbuckle ball cups as shown, using your needlenose pliers. Assemble both right and left sides.

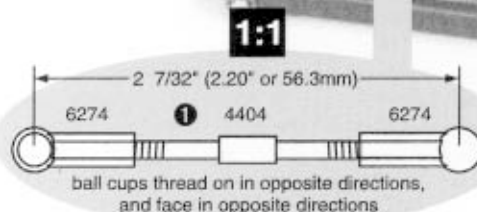
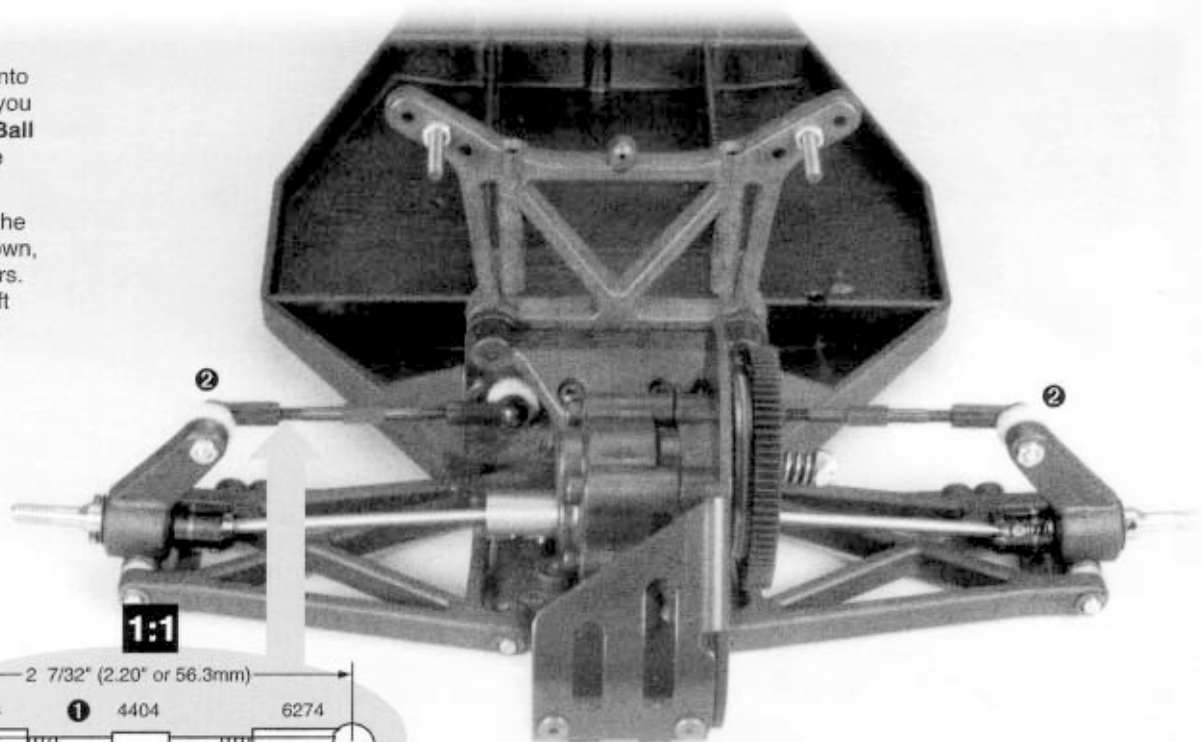













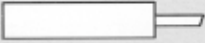

#9011 SPORT KIT SHOWN

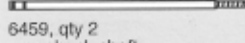
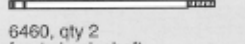
BAG F

REMOVE THESE PARTS FOR:

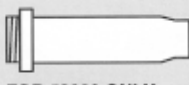
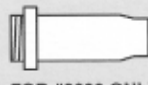
9000: steps 1-4

9011: steps 1-4

1:1  5407, qty 8 red O-ring	1:1  6299, qty 8 E-clip	 6429, qty 1 shock assembly tool	1:1  6440, qty 4 split locking washer	1:1  6440, qty 8 small washer	1:1  6440, qty 4 large spacer	 6459, qty 2 rear shock shaft	 6460, qty 2 front shock shaft
1:1  6465, qty 2 shock piston #1	1:1  6465, qty 2 shock piston #2	 6428, qty 4 shock cap	1:1  6469, qty 4 large O-ring	 FOR #9000 ONLY 6435, qty 2 rear shock body FOR #9011 ONLY 6424, qty 2 rear shock body	 FOR #9000 ONLY 9310, qty 2 front shock body FOR #9011 ONLY 9311, qty 2 front shock body	 5428, qty 1 25 wt silicone oil	
1:1  7217, qty 4 pivot ball plastic	 7217, qty 4 eyelet nylon						

TOOLS USED

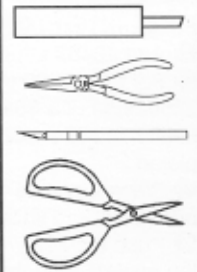

STEP 1

TRIM SHOCK PISTONS

1 Burrs interfere with smooth shock action within the shock body. To remove from tree without creating burrs, twist up, not down. Remove two each of #1 and #2.
2 Remove remaining burrs carefully with hobby knife.

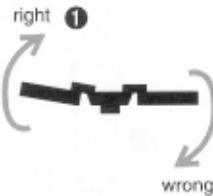

TRIM SHOCK WASHERS & SPACERS

For best shock performance, trim each part from the parts tree so no part of the two molding runners remain. It is safer to remove a tiny amount of the part than to risk the chance of a burr remaining. Short blade scissors or a hobby knife will work fine, as shown at right. Run your finger over the edges to feel for burrs you cannot see. Remove the ones you find. Burrs can keep the parts from snapping in correctly, and can cause the shock to leak or the shaft to jam.



STEP 2

SHOCK SEAL PARTS

1 Install the #5407 and #6440 parts shown onto the #6429 tool tip.
2 Add 3-4 drops of #5428 oil to the inside of the shock body, and to the shock seal parts.
3 Insert the tool tip into the shock body all the way. Push easily until the parts snap into place.

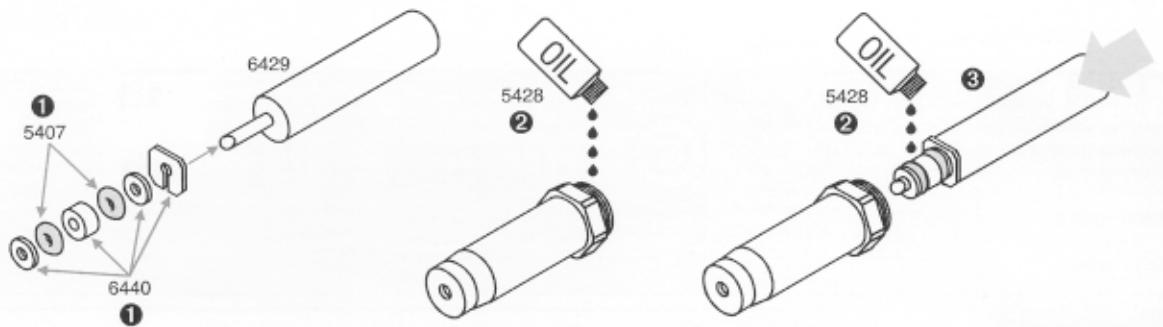

4 Check the tool height in photo. The right shock shows just before snapping parts in place, the left shows after.
5 If your shocks do not snap together easily, check the parts for burrs again.
6 Assemble the other shock bodies the same.

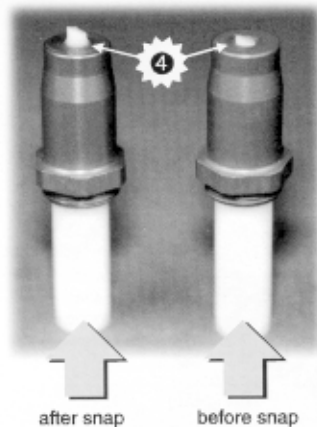

DISMANTLING THE SHOCKS WHEN IT'S REBUILD TIME

1 Put the shock assembly tooltip into the bottom of the shock until it rests against the small washer, as shown, then push.

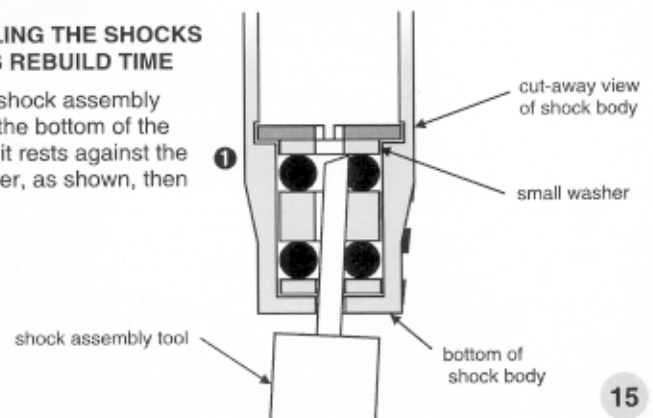

STEP 4

FINAL INTERNAL SHOCK ASSEMBLY

- 1 Add #6469 O-ring over threads of shock body.
- 2 For the #6460 front shock shaft, install a #6299 E-clip on either side of a #6465 (#2) piston. For the #6459 rear shock shafts, install a #6299 E-clip on either side of a #6465 (#1) piston.
- 3 Place a couple drops of #5428 oil on threaded part of shaft and insert into shock body.
- 4 Push the #7217 pivot ball and eyelet together, then screw the eyelets onto the end of the shock shaft. Hold shaft with rag and needlenose pliers next to threads.

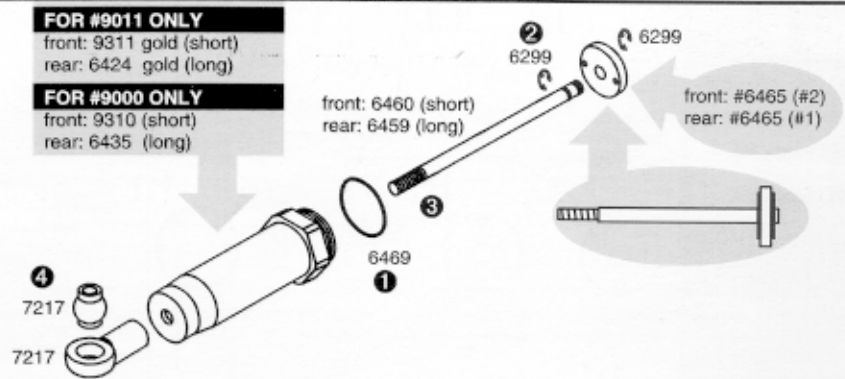

STEP 5

FILLING THE SHOCKS

- 1 Holding the shocks upright, fill with oil to the top of the shock body.
- 2 Slowly move the shaft up and down several times to allow air bubbles to escape to the top.
- 3 Refill with oil to the top of the shock body.
- 4 Push the shaft all the way up into the shock body. The oil will slightly bulge up above the shock body.
- 5 Install the #6428 shock cap and tighten. There should be no gap between the cap and the hex portion of the shock body when tight.

SETTING THE REBOUND

- 6 Move the shock shaft in and out a few times and then push it all the way in. It should be easy to push the shaft in until the eyelet hits the body.
- 7 Then the shaft should push itself out approximately 1/4" to 3/8" (6.3mm - 9.5mm").
- 8 If the shocks do not push out this far, there is not enough oil in them. Add just a little oil and try steps 6-7 again.
- 9 If the shocks push out farther than the distance in step seven, or you cannot push the shaft in until the eyelet hits the body, there is too much oil. Loosen the cap a half turn (with the shaft extended) and pump out a small amount of oil by pushing the shaft in. Retighten the cap and try steps 6-7 again.

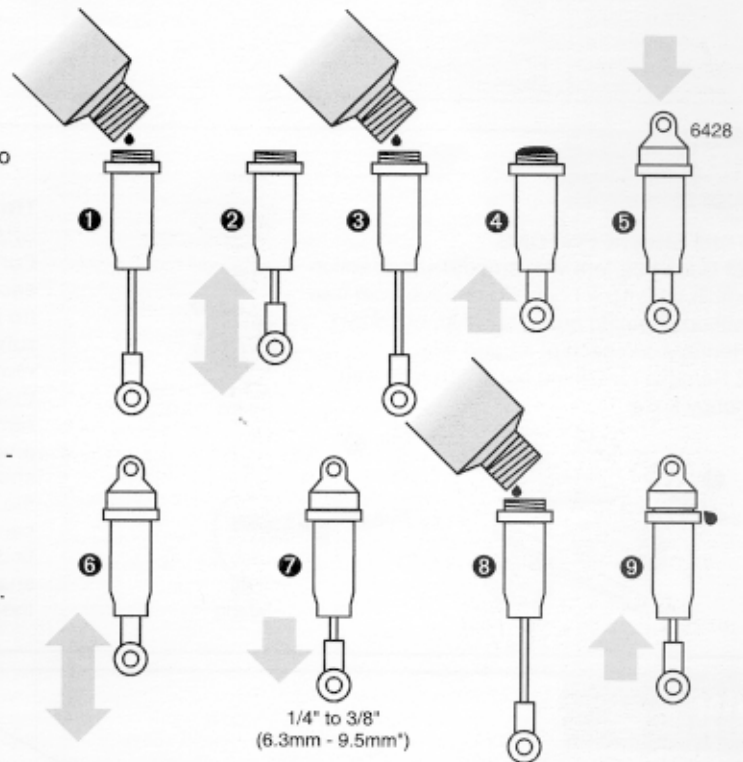

BAG F

REMOVE THESE PARTS FOR:

9000: step 6

9011: step 6



6474, qty 4
spring clamp



6474, qty 4
spring collar



6474, qty 4
spring cup



6478, qty 2
rear spring
silver



6494, qty 2
front spring
green



6932, qty 4
4-40 x 5/16

1:1

TOOLS USED

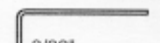

STEP 6

FINAL SHOCK ASSEMBLY

- 1 Assemble all four shocks at the same time. Pull the shock shaft out as far as it will go.
- 2 Start the #6932 screw into the #6474 spring clamp, then slide the clamp up the shock body as far as it will go.
- 3 Slide on the spring collar, then spring, then spring cup, orienting them according to the drawing. *Remember: long springs for long shocks.*
- 4 Adjust the spring clamps to the dimensions shown, then tighten the #6932 screw to hold them there. Do the other three shocks.



DRAWINGS NOT ACTUAL SIZE

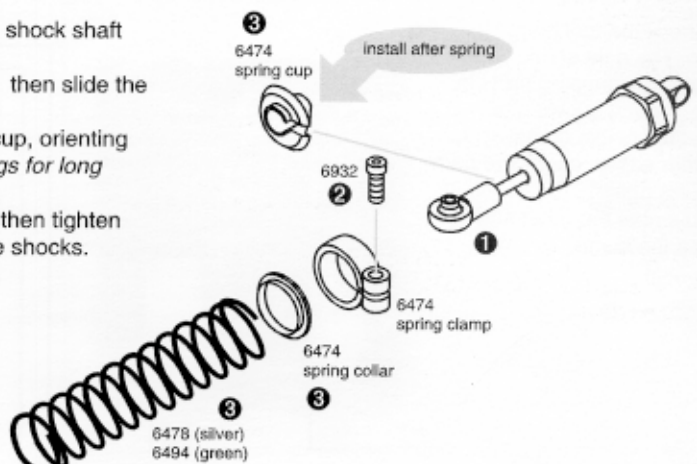

BAG F

REMOVE THESE PARTS FOR:

9000: steps 7-8

9011: steps 7-8



1:1
6222, qty 4
4-40/5-40
locknut

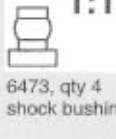

1:1
6473, qty 4
shock bushing



1:1
6918, qty 2
4-40 x 1/2

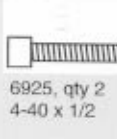

1:1
6925, qty 2
4-40 x 1/2

TOOLS USED

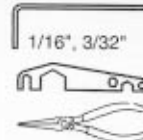

STEP 7 RIGHT SIDE

REAR SHOCK MOUNTING

- 1 Add the #6473 bushings as shown.
- 2 Push cap over bushing and add #6222 locknut. Do not overtighten or the shock will bind.
- 3 Fasten the lower shock with the #6925 screw into the arm outer hole.

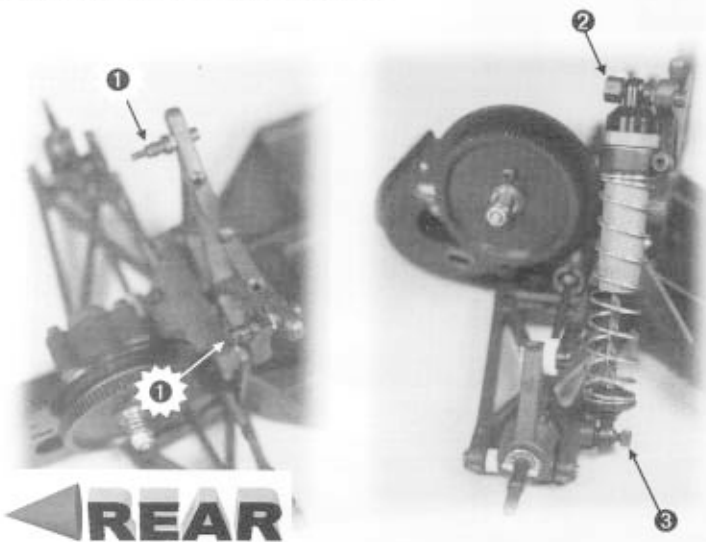
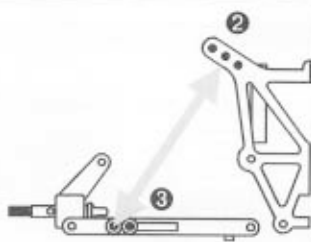

◀ REAR

STEP 8 RIGHT SIDE

FRONT SHOCK MOUNTING

- 1 Add the #6473 bushings as shown.
- 2 Push cap over bushing and add #6222 locknut. Do not overtighten or the shock will bind.
- 3 Fasten the lower shock with the #6918 screw into the arm inner hole
- 4 Do the other front shock.

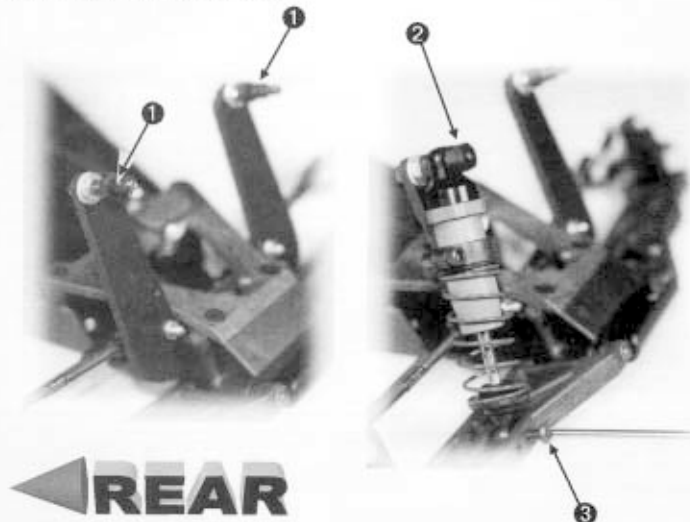
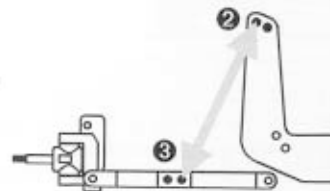

◀ REAR

BAG G

REMOVE THESE PARTS FOR:

9000: step 1

9011: step 1



1:1
6270, qty 1
ball end



1:1
6272, qty 1
dust cover



1:1
6917, qty 4
4-40 x 3/8



1:1
7336, qty 2
servo mount



1:1
7336, qty 2
servo mount
spacer



1:1
7337, qty 4
washer

9180, qty 1 ea
servo horns



TOOLS USED

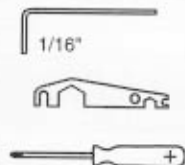

STEP 1

ASSEMBLE THE SERVO

- 1 Find the appropriate #9180 servo horn for your servo, marked "A" for Airtronics, "F" for Futaba, "J" for JRPropo. Remove the servo horn from your servo and replace with the #9180 horn, then fasten with the stock mounting screw.
- 2 Install the #6270 ball end into the servo horn. Add the #6272 dust cover.
- 3 Attach the #7336 mounts with the #6917 screws and #7337 washers. Add the #7336 spacers if you have an Airtronics servo.

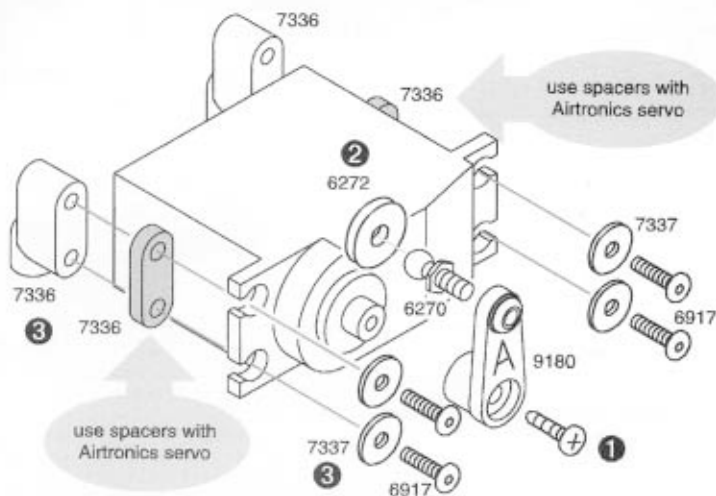

use spacers with Airtronics servo

use spacers with Airtronics servo

BAG G

REMOVE THESE PARTS FOR:

9000: step 2

9011: step 2



TOOLS USED

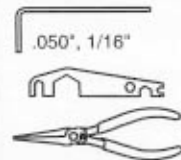

STEP 2 RIGHT SIDE

MOUNT THE SERVO

- 1 Mount the servo with two #7673 screws.
- 2 Assemble the #9170 servo link, matching the length to the true scale drawing.
- 3 Use needle-nose pliers to attach link to ball ends.

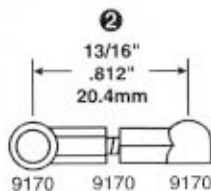

1:1

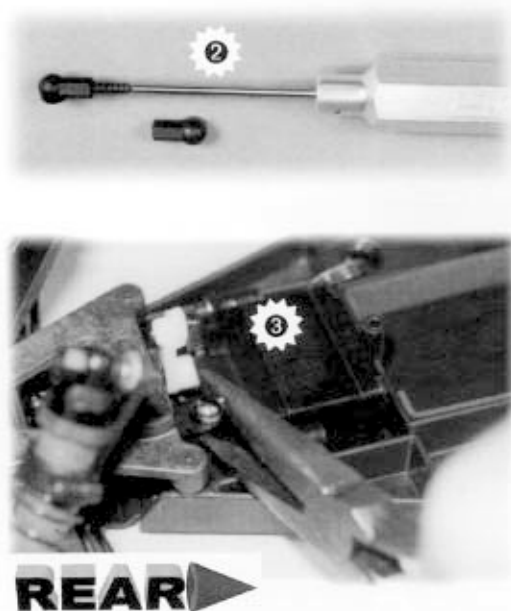
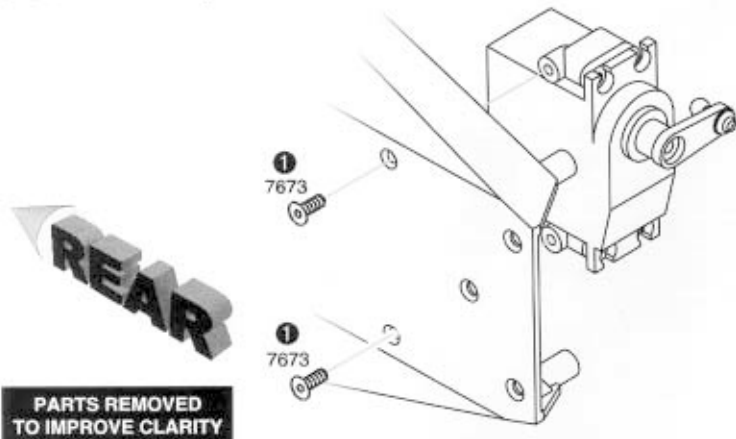

BAG G

REMOVE THESE PARTS FOR:

9000: step 3

9011: step 3



TOOLS USED

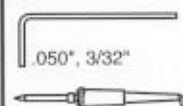

STEP 3 RIGHT SIDE

INSTALL THE MOTOR

- 1 Attach three capacitors to your motor according to the instructions that came with your motor, if they are not on already. For the #9011 kit, solder the colored plug wire to a positive tab on the motor and the black wire to a negative tab. For the #9000 kit, you must buy your own motor, then follow this step.
- 2 Install the #6681 gear with the #6951 set screw going to the flat side of the shaft. For the #9000 kit, you must buy your own pinion gear. If you use an electronic speed control, see its directions for installing motor capacitors.
- 3 Use two #6515 screws and two #6936 washers to mount the motor as shown so the gears mesh.

SET THE GEAR MESH

- 4 You should be able to rock the spur gear back and forth in the teeth of the pinion gear without making the pinion gear move. If the plastic gear is tight, then loosen the #6515 screws and move the motor away, then try again. A gear mesh that is too tight or too loose will reduce power and damage the gear teeth.

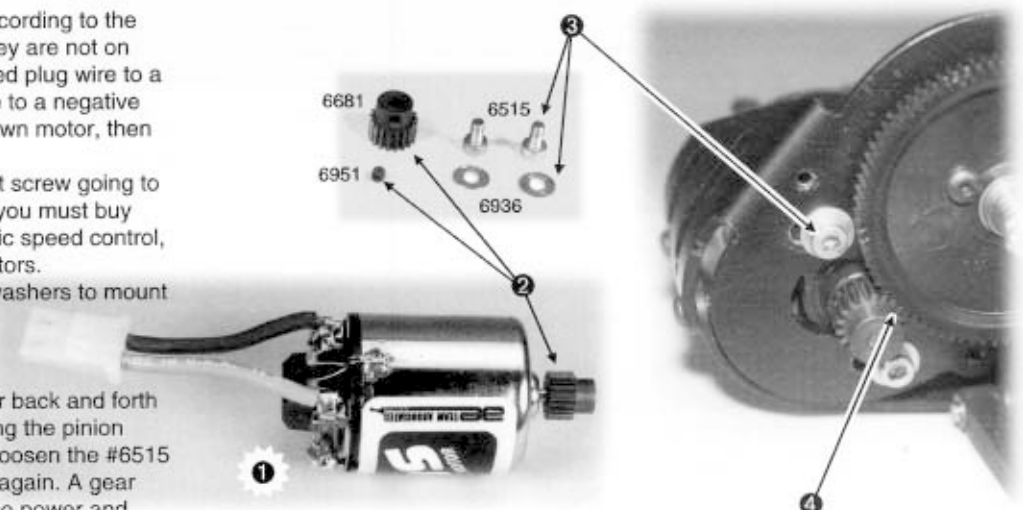

#9011 KIT ONLY

BAG G

REMOVE THESE PARTS FOR:

9011: steps 4-6

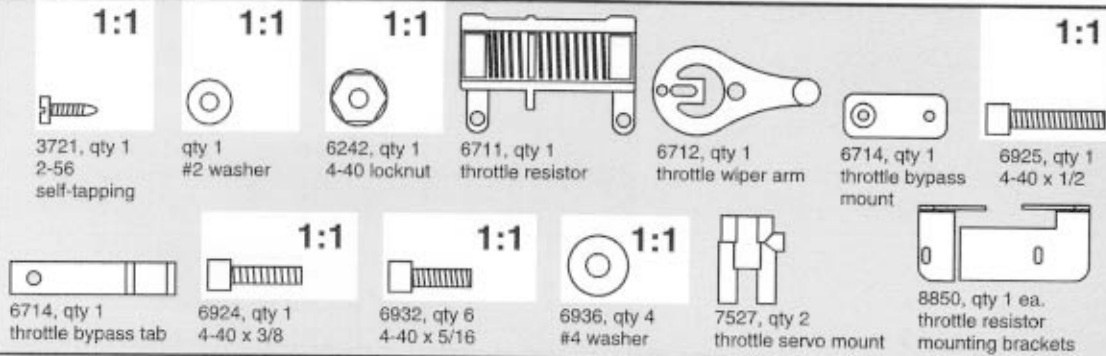

TOOLS USED

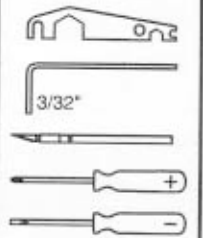

STEP 4

MOUNTS TO SPEED CONTROL

1 Attach the #7527 mounts to the speed control with four #6932 screws and four #6936 washers. Orient your servo output shaft as shown here.

RESISTOR TO SPEED CONTROL

2 Push the #8850 brackets into the #6711 resistor.

3 Attach the brackets to the mounts by two #6932 screws and two #6936 washers.

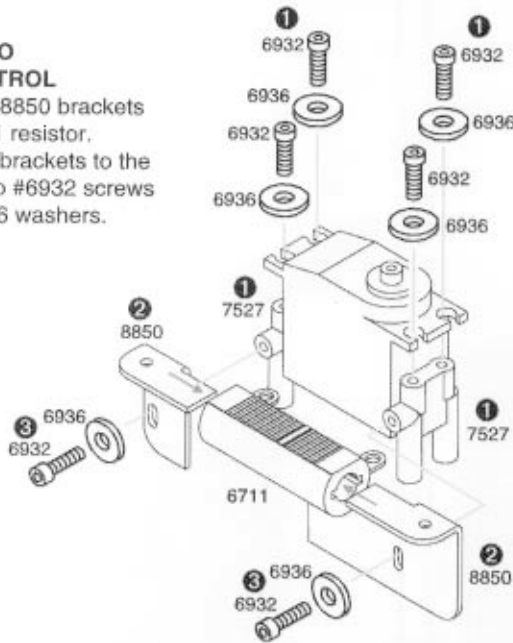

STEP 5

MODIFY THE SERVO HORN

1 There are many servo horns available. The round one is the best one.

2 You must modify the horn if you are not using the round one. Trim them so they don't go beyond the #6712 throttle wiper arm.

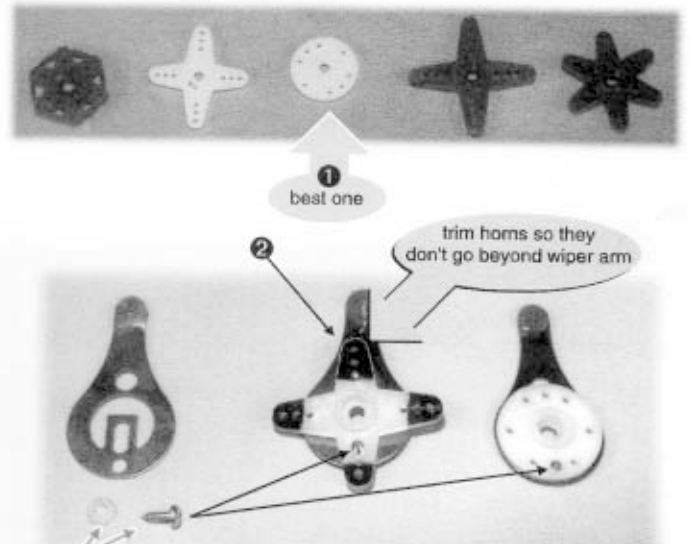

STEP 6

FINAL RESISTOR/SPEED CONTROL ASSEMBLY

1 Attach the #6712 arm to the horn with the #2 screw and washer.

2 Mount the arm and horn to the servo. Then trim the screw tip if it contacts the servo body.

3 Add the #6714 mount using #6925 screw and #6242 locknut.

4 Add the #6714 bypass tab to the #6714 mount with a #6924 screw and #6936 washer.

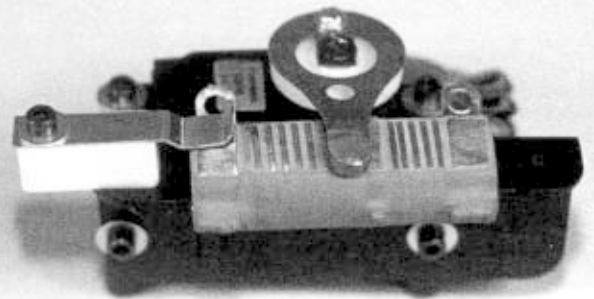
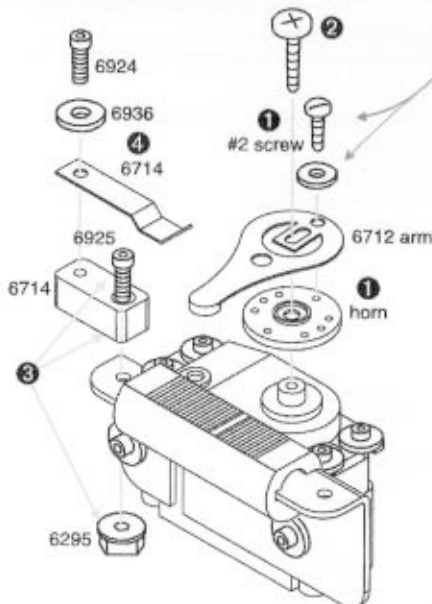

ASSEMBLED THROTTLE SERVO AND RESISTOR

#9011 KIT ONLY

BAG G

REMOVE THESE PARTS FOR:

9011: steps 7-8

1:1



6917, qty 2
4-40 x 3/8



6747, qty 1
battery input harness

6745, qty 1
motor output harness



qty 1
servo tape
(roll, #6726)

TOOLS USED

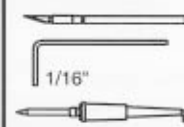

STEP 7

WIRE THE RESISTOR

- 1 Solder the small red wire between the positive resistor tab and the brass bypass tab.
- 2 Solder the #6745 harness to the wiper arm and negative tab on the resistor.
- 3 Solder the #6747 harness to the positive and negative tabs on the resistor.
- 4 Run the wire of the servo attached to the resistor through the battery slot area.

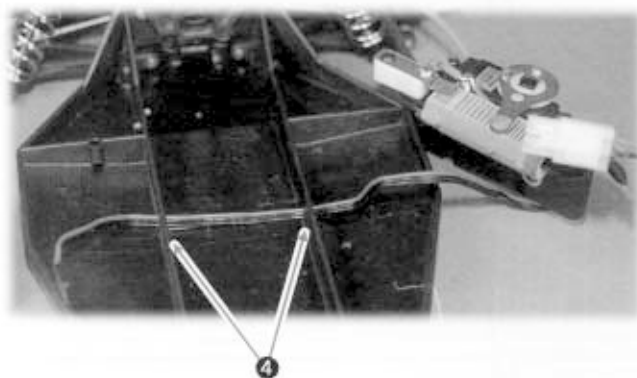
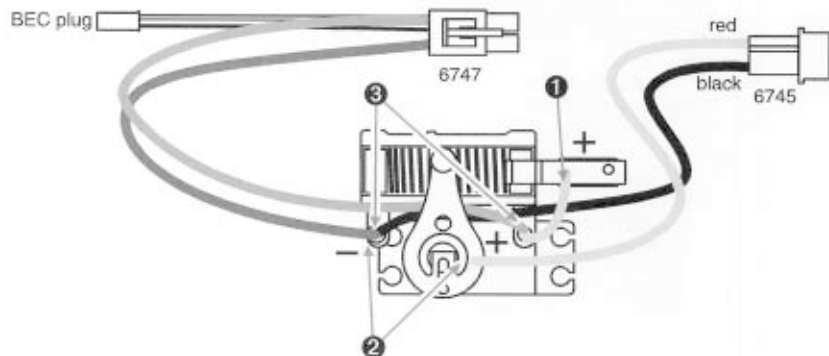

PARTS REMOVED TO IMPROVE CLARITY

STEP 8 LEFT SIDE

SPEED CONTROL TO CHASSIS

- 1 Attach speed control to chassis with two #6917 screws from the bottom.

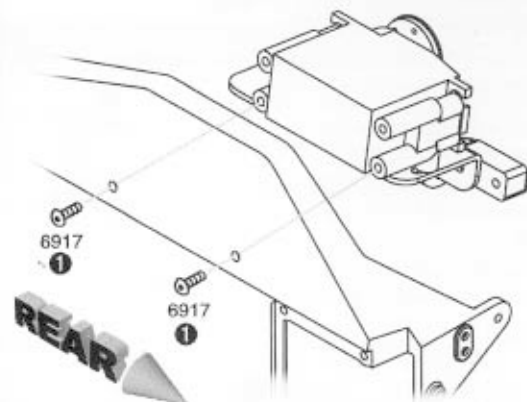

PARTS REMOVED TO IMPROVE CLARITY

REAR

STEP 9 LEFT SIDE

RADIO RECEIVER TO CHASSIS

- 1 Cut a piece of servo tape, remove the paper from one side, and attach it to the bottom of your servo.
- 2 Slip the receiver wire through the built-in chassis antenna mount.
- 3 Remove the paper from the other side and attach to the chassis as shown.
- 4 Plug the small #6747 BEC plug (of step 7) into the receiver's on/off switch.
- 5 Follow the instructions that accompany your radio receiver system.

REAR

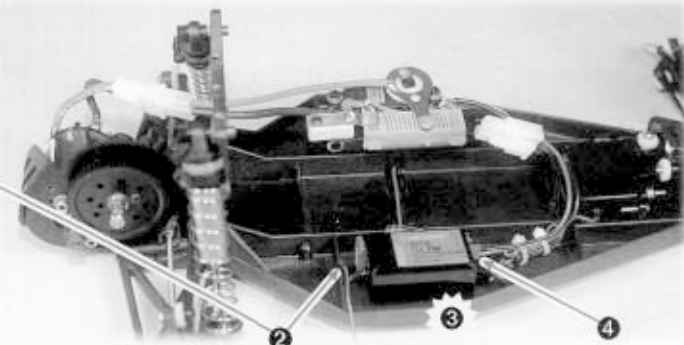
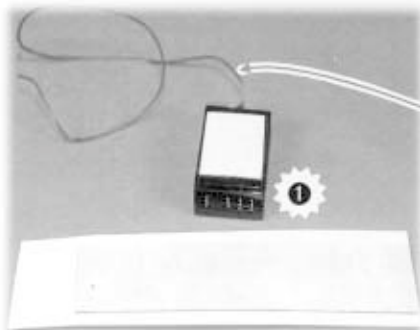

BAG H

REMOVE THESE PARTS FOR:

9000: steps 1-2

9011: steps 1-2



6285, qty 2
4-40 x 1/4



6332, qty 1
body clip

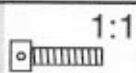

6929, qty 1
4-40 x 3/8

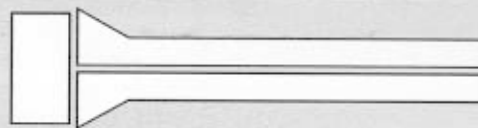

9235, qty 1
foam battery pads

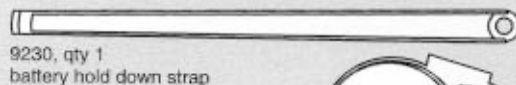

9230, qty 1
battery hold down strap

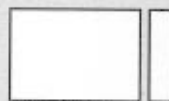

9238, qty 2
battery spacer



9247, qty 1
button



9247, qty 1
gear cover

TOOLS USED



STEP 1 LEFT SIDE

INSTALLING THE BATTERY PACK

- 1 Install the three #9235 foam battery pads.
- 2 Install the two #9238 foam battery spacers. (The tuning section will show you how to adjust your steering or traction by moving these spacers.)
- 3 Install your battery pack. (See step 5 if you need to assemble it first.)
- 4 Thread on the #6929 screw. Aim the body clip hole across the chassis. Add the #9230 battery hold down strap. Adjust the screw so the batteries are held tight, but you are still able to push the #6332 body clip through the screw.

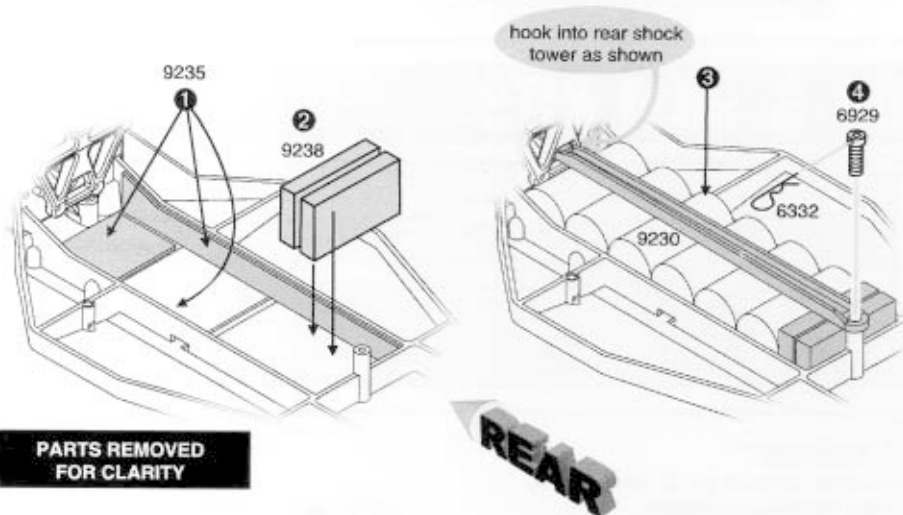

PARTS REMOVED FOR CLARITY

SOLDERING INDIVIDUAL CELLS

- 5 Solder connections properly to assemble a battery pack from individual cells. Team racers prefer battery bars or braid for sturdier connections. Insulated wire will not allow the pack to fit in the battery slot.

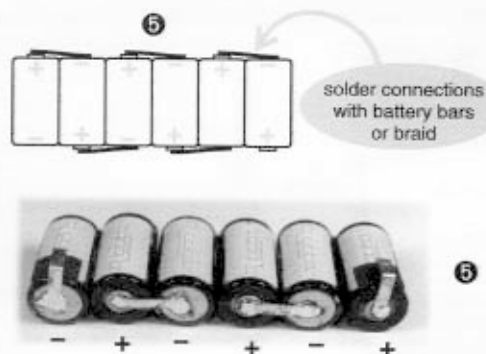

BATTERY PRODUCTS ARE NOT INCLUDED IN KIT

STEP 2 RIGHT SIDE

GEAR COVER

- 1 Trim the #9247 gear cover, cutting out three holes shown. Insert the #9247 insert button into the large hole cut into the gear cover.
- 2 Mount the cover with two #6285 screws.

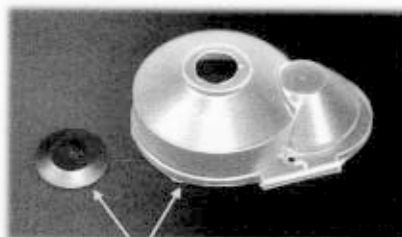

9247
1



6285
2

REAR

#9000 KIT ONLY

BAG H

REMOVE THESE PARTS FOR:

9000: step 1

qty 1
servo tape



TOOLS USED



STEP 1

RADIO AND RECIEVER INSTALLATION

- 1 Install your battery pack as shown. If you need to assemble the battery, see step 1 #5 on page 21.
- 2 Cut a piece of servo tape and use it to attach your ESC where shown.
- 3 Cut a piece of servo tape and use it to attach your reciever where shown.
- 4 Connect the ESC and steering servo to your receiver according to your radio or ESC instructions, then connect the motor to your ESC.

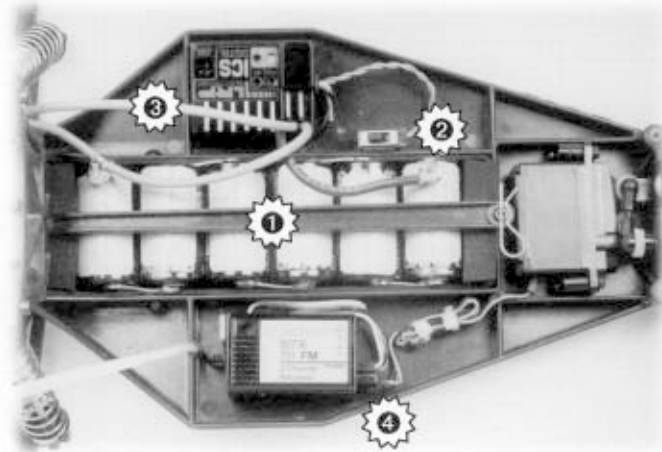

#9000 & 9011 KITS

BAG H

REMOVE THESE PARTS FOR:

9000: step 3

9011: step 3

1:1



4436, qty 2
4-40 x 5/16



6182, qty 1
wing



6190, qty 2
wing thing



6332, qty 2
body clip



9454, qty 1
.065" wing wire

TOOLS USED



STEP 3

BODY MOUNTING

- 1 Trim and paint the body. For #9000 kit: #6133 body. For the #9011 kit: #6140 body. (See painting instructions later if you have not done this before.)
- 2 Secure the body to the chassis with two #6332 body clips where shown.

WING ASSEMBLY

- 3 Trim and paint the #6182 wing. Make two holes for the wing things.
- 4 Insert the #6190 wing things. Insert the #9454 wire through the wing things.
- 5 Secure the wire to the wing things with the #4436 set screws.

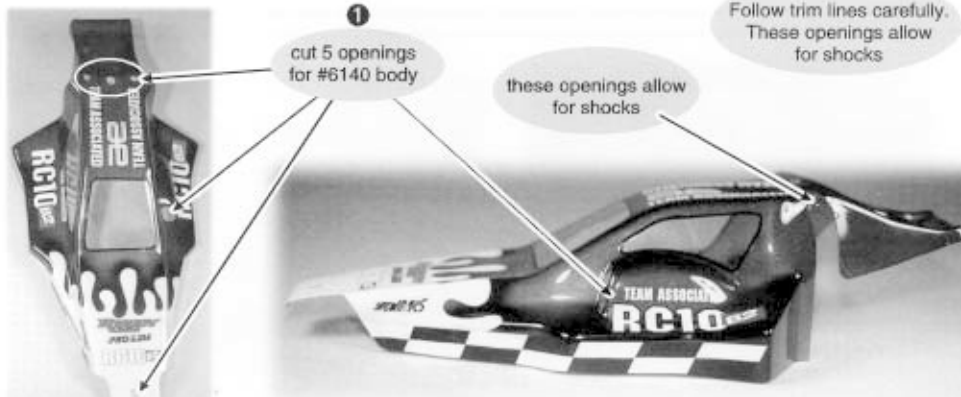

22

#6140 BODY SHOWN

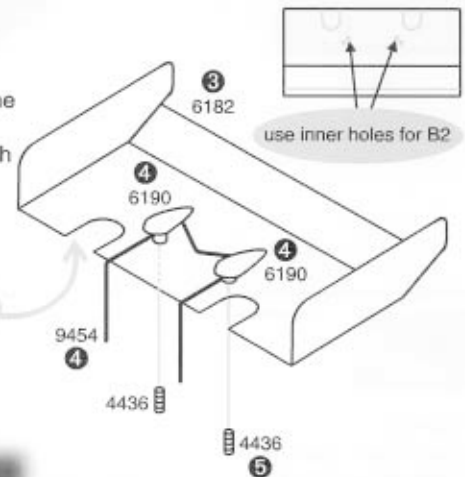

BAG H

REMOVE THESE PARTS FOR:

9000: step 4

9011: step 4

6338, qty 1
antenna tube cap

6338, qty 1
antenna tube

STEP 4

MOUNT THE ANTENNA

- 1 Push your receiver wire through the built-in antenna mount hole.
- 2 Thread the wire through the #6338 antenna and push the antenna firmly into the chassis' antenna mount hole.
- 3 Cap the other end of the antenna tube and wire.

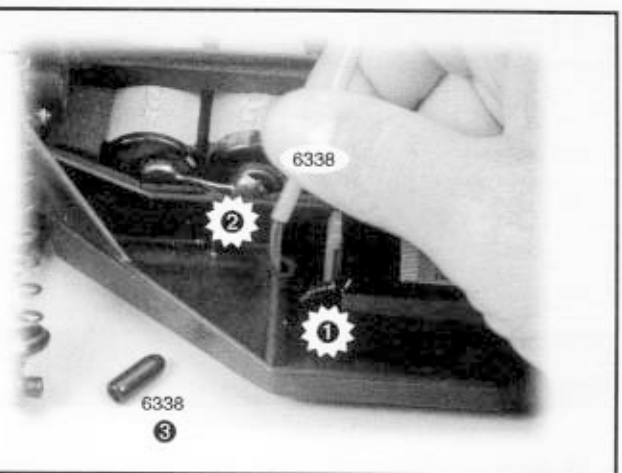

BAG I

REMOVE THESE PARTS FOR:

9011: steps 1-2



6804Y, qty pr
3 piece rear wheels



6854Y, qty pr
3 piece front wheels



6823, qty 2
Step Pin rear tire



6874, qty 2
Flat 4 Rib front tire



3438, qty 2
8-32 locknut



6222, qty 2
4-40/5-40
locknut



6599, qty 4
3/16 x 3/8
unflanged bushing



6924, qty 6
4-40 x 3/8

TOOLS USED

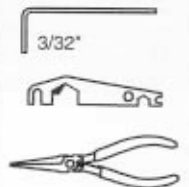

STEP 1

#9011 KIT ONLY

REAR WHEELS AND TIRES

- 1 Make a 1/8" hole in the inner ring. Slip the #6804Y ring into the #6823 rear tires.
- 2 Using your finger, coat each edge of the tire that contacts the two wheel halves with liquid dish soap.
- 3 Push the #6804Y wheel halves into either side of the tire so they interlock.
- 4 Add three #6924 screws to fasten wheel together. Push wheel onto axle so roll pin engages slot in wheel.
- 5 Install #3438 locknut to axle. Finish the other side.

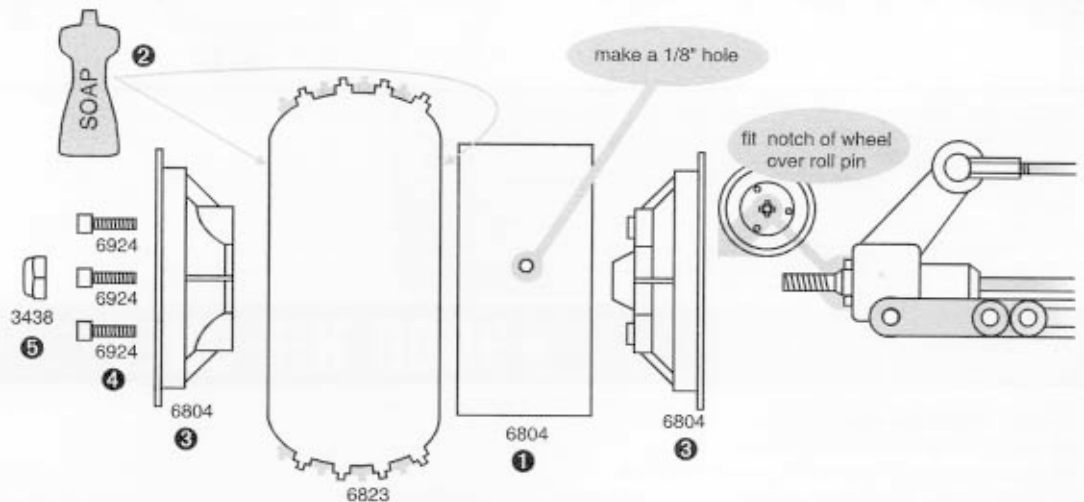

STEP 2

#9011 KIT ONLY

FRONT WHEELS AND TIRES

- 1 Make a 1/8" hole in inner ring. Slip the #6854Y ring into the #6874 front tire.
- 2 Using your finger, coat each edge of the tire that contacts the two wheel halves with dish soap.
- 3 Push the #6854Y wheel halves into either side of the tire so they interlock.
- 4 Add three #6924 screws to fasten wheel together.
- 5 Insert #6599 bushings into both sides of front wheel.
- 6 Install wheel onto axle. Install #6222 locknut onto axle. Assemble the other wheel.

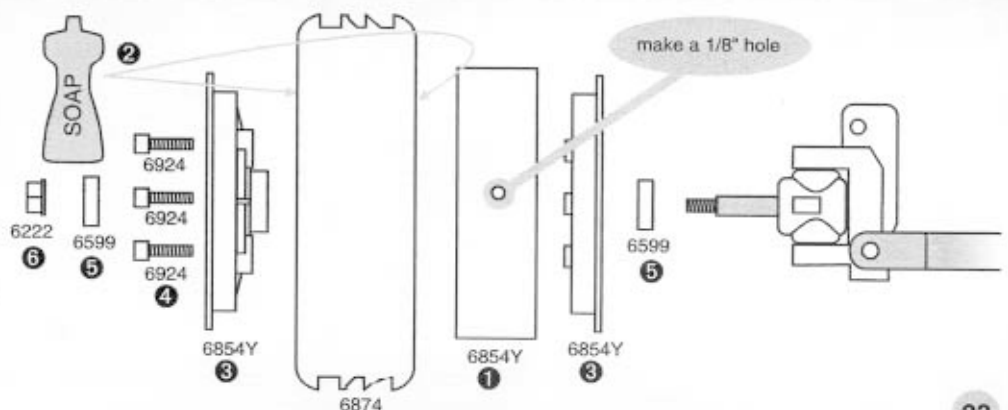

BAG 1

REMOVE THESE PARTS FOR:

9000: steps 1-2



9490Y, qty pr
1 piece rear wheels



9480Y, qty pr
1 piece front wheels



6824, qty 2
Flat Stubby rear tire



6877, qty 2
Edge front tire



1:1

3438, qty 2
8-32 locknut



1:1

6222, qty 2
4-40/5-40
locknut



1:1

6906, qty 4
3/16 x 3/8
unflanged ball bearing

TOOLS USED

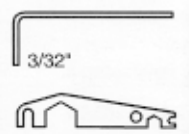

STEP 1

#9000 KIT ONLY

REAR WHEELS AND TIRES

- 1 Make a 1/8" hole in the wheel. Make sure foam insert is centered in tire.
- 2 Install the #6824 tire to the #9490Y wheel.
- 3 Glue the tire to the wheel with super glue (cyanoacrylic glue) in four spots around the tire on both sides. **WARNING!** Follow the adhesive manufacturer's instructions for proper use and safety. Wear eye and hand protection.
- 4 Install wheel onto axle, lining up roll pin with slot in the wheel. Thread on the #6296 locknut. Finish second rear wheel and tire.

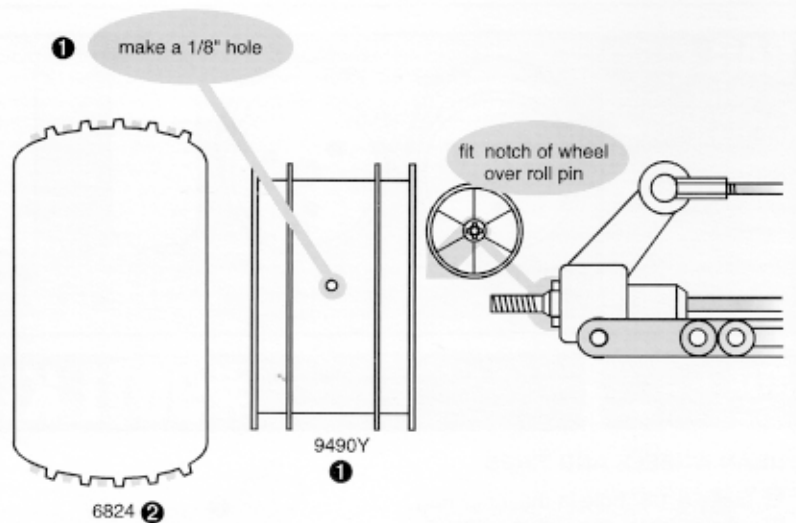
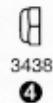
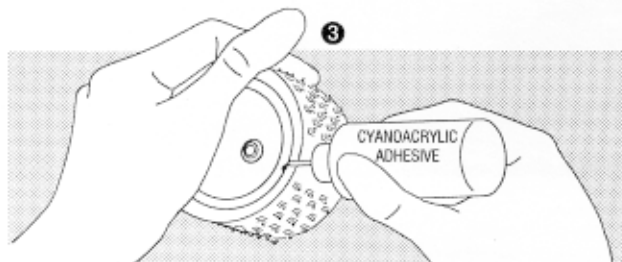

MULTIPLE-CHOICE QUIZ:

For protective measures when using cyanoacrylic glue products, you should:

- Read the product manufacturer's warning labels and follow them.
- Wear eye protection.
- Wear hand protection.
- If unsure, have an adult complete the step.

Answer: all of the above.

STEP 2

#9000 KIT ONLY

FRONT WHEELS AND TIRES

- 1 Make a 1/8" hole in the wheel.
- 2 Install the #6877 tire to the #9480Y wheel.
- 3 Glue the tire to the wheel with super glue (cyanoacrylic glue) in four spots around the tire on both sides. **WARNING!** Follow the adhesive manufacturer's instructions for proper use and safety. Wear eye and hand protection.
- 4 Insert the #6906 ball bearings into both sides of the front wheel.
- 5 Install wheel onto axle. Thread on #6222 locknut. Finish second rear wheel and tire.

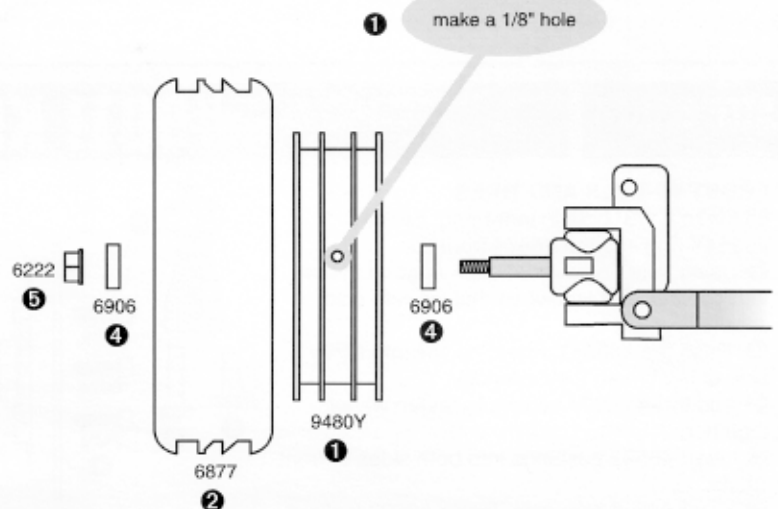
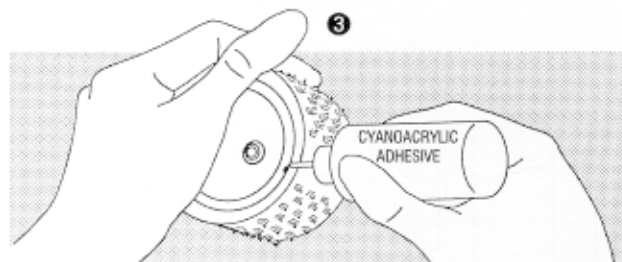

WRITE-OUT-YOUR-ANSWER QUIZ:

- 1 Why are you not using protective gloves and eyewear like we told you?
- 2 Didn't you read the warnings regarding your safety?

FINAL ADJUSTMENTS

BATTERY CHARGING. Charge the transmitter batteries if they are NiCads. (Battery charging instructions are found later on this page.) Next charge your battery pack according to the instructions included with your battery charger or battery pack. Make sure all the ESC or mechanical speed control connections are according to the appropriate manuals. Now use the following steps to make the final adjustments on your car.

- 1 Turn the transmitter switch ON
- 2 Make sure the motor is unplugged or unsoldered.
- 3 Plug in or solder in your battery pack.
- 4 Turn the car switch to the ON position. (This will be attached to the ESC or will be the separate on/off switch supplied with your radio system.)
- 5 Move the steering control on the transmitter to the right. Do the wheels steer to the right? If not, you must reverse the steering servo direction on your transmitter (see radio manual).
- 6 After you have the wheels steering in the correct direction, remove your hand from the steering control on the transmitter. Now look at the servo horn mounted on the servo. Is it pointing straight up? If not, adjust its position with the steering trim control on the transmitter, or move its position on the servo.
- 7 Now look at your front wheels. Are they pointed straight ahead in relation to the center line of the chassis? If not, first check the alignment of the servo saver arms in relation to the servo horn. With the horn pointed straight up, the steering servo saver arms should be parallel. Use the servo link to make any adjustments. Do they now point straight ahead? If not, use the steering tie-rod turnbuckles to adjust each wheel so that it is pointed straight ahead.

8 (#9011 mechanical throttle resistor only) Our mechanical speed control is set up for a 70/30 throttle/brake setting. Now check the direction and travel of the throttle servo. The wiper should move to the right and under the bypass tab for forward, and to the left for brake. If the throttle servo moves in the opposite direction, locate the throttle servo reversing switch (on your transmitter) and move it to the opposite position. If your radio does not have a 70/30 setting, it may still work but will require a different setting.

Just to the left of center is the neutral band (it is slightly wider than the other resistor bands). We want the wiper arm contact button over the wide neutral band. It should not be mak-

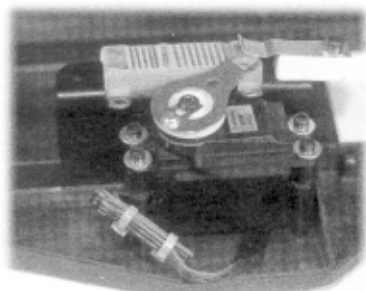

FORWARD

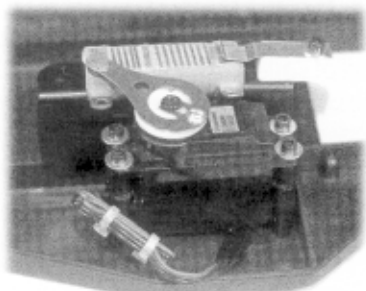

BRAKE

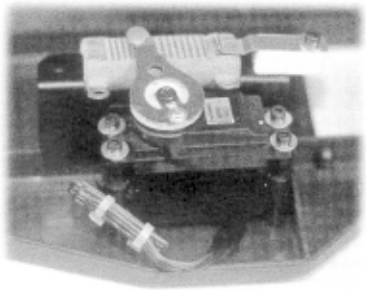

NEUTRAL

ing contact with any of the forward bands (to the right side) at the same time. Use the throttle servo trim control to adjust the neutral position. If it is beyond the range of the trim feature you will need to center the trim knob and rotate the servo horn.

8 (Racer Kit) Adjust the ESC (electronic speed control) according to the speed control manufacturer's instructions. **Note:** Some manufacturers have the motor connected during adjustment and some do not. Now turn the car ON/OFF switch OFF.

9 Plug in or solder in your motor. Place your car on a block or car stand so that the rear wheels cannot touch anything. Turn the car switch back ON. Check the throttle resistor or ESC operation and settings. After you have set and checked the throttle resistor speed or speed control, turn the car switch OFF.

10 The transmitter switch must always be the **FIRST SWITCH TURNED ON** and **THE LAST SWITCH TURNED OFF**.

CONGRATULATIONS! YOUR CAR IS NOW READY TO RUN!

PAINT THE BODY & WING

1 While the body is still clear, cut out the holes for the body mounts and antenna tube.

2 Clean the body and wing thoroughly before painting with warm water and a mild dish soap.

3 Mask the inside of the body according to your paint scheme, using automotive masking tape for the best results. Take the time to press down all edges of the tape. Mask off the holes you cut with tape on the outside of the body.

4 Spray the body and wing, applying the paint in thin coats and letting it dry between coats. We recommend Pactra paints.

BATTERY CHARGING & DISCHARGING

The battery packs used for R/C cars are six-cell, sub-C, rechargeable type found in any hobby shop.

CHARGING. Proper battery charging and discharging is important to maintain the performance and life of your battery pack.

Associated recommends the use of a good quality automatic peak detection type charger. Peak detection chargers will automatically sense when the battery pack is fully charged and shut off, thus lessening the chance of damage due to overcharging. Timer chargers are not recommended because a mistake can be made, thus damaging the battery pack.

DISCHARGING. To maintain performance from your battery packs, it is recommended you completely discharge them between charges. There are several inexpensive dischargers available at your hobby shop. Associated recommends the light bulb type discharger that is popular with the racers. Follow the discharging instructions supplied with your discharger for best battery performance

ASSOCIATED CHARGE CORD

In your #9011 kit is the Associated #3736 six cell (7.2 volt) charge cord. While we still recommend the use of a peak detection battery charger, this may not be within the budget of every hobbyist. When assembled, this charge cord will allow you to charge your battery packs from any 12 volt automotive type battery.

1 In the charge cord bag you will find two large alligator clips, red and black plastic sleeves, and two different types of wire. Before you can solder, install one of the red sleeves over the positive wire and a black sleeve over the negative wire. **WARNING! DO NOT SHORTEN EITHER WIRE.** The arrows in the photo are pointing to the positive wire and clip connector. The positive lead will be the silver wire with the clear plastic coating over it. The negative wire is the black wire.

2 Strip $\frac{1}{2}$ " of the clear plastic coating from the silver positive wire with your hobby knife. Insert the wire into one side of the alligator clip and solder it to the clip in the location shown in the photo. **Use Rosin core solder only.**

3 At the end of the alligator clip there are two tabs. Bend these tightly over the coated wire to help relieve the strain on the solder connection. Slide the red sleeve back over the arm on the alligator clip.

4 Now take the second red sleeve and slide it over the other arm of the alligator clip. Repeat the above for the black negative wire and the black plastic sleeves.

CHARGE CORD CHARGING INSTRUCTIONS

First make sure your Ni-Cad battery pack is fully discharged and cool. Connect the red clip to the positive terminal of your 12 volt battery, then connect the black clip to the negative terminal. **Always do this first, before you connect the charge cord to your battery pack.**

You are now ready to charge your battery pack. Plug the white battery connector plug (on the end of the charge cord) into the mating plug on your battery pack. You are now charging your battery. The charge cord will start out with a charge of approximately 4.5 amps and as the battery charges this will reduce to approximately 2.5 amps. Normally it will take about 15 minutes to charge your pack (make sure you start with a discharged pack).

CAUTION! If you are using the charge cord (supplied in the #9011 kit) or some other method of timed charge, you should monitor the battery temperature while charging. Simply feel the battery temperature with your hand as the pack is charging. As soon as the pack feels warmer than the room temperature you should stop charging. If you continue charging, you may damage the battery pack.

WARNING! Charge cords and batteries can get extremely hot during charging cycles. Care must be taken around any components that can be damaged or catch fire due to heat from the charge cord or battery pack. This system is designed for use with an automotive 12 volt battery only. It cannot be used with a power supply or battery charger due to the higher voltage output.

WARNING! If you need to charge the 12 volt automotive battery you must disconnect any battery pack that is charging. After you have charged the 12 volt automotive battery you can resume charging the battery packs.

MAINTENANCE

You should periodically check all the moving parts: front and rear suspension arms, steering blocks, steering linkage, shocks, and so on. If any of these should get any dirt in them, then your car's performance will suffer.

MOTOR MAINTENANCE. Between runs, inspect the brushes to insure they are moving freely in the brush holder. This is done by carefully removing the spring and sliding the brush in and out of the holder. If there is any resistance or rough spots, remove the brush and carefully wipe the brush clean. This will clean off any build-up and lubricate the brush so it slides smoothly in the brush holder.

After every 3 to 5 runs, remove the brushes from the holders and inspect the tips for wear and/or burning. If there is a noticeable amount of wear, replace the brush with a new pair. If the tip is a burnt blue color, then the lubricant in the brush has been burned away and new brushes should be installed.

After every other battery charge you should carefully clean the motor. One recommended method is to spray motor cleaner directly on the brush and commutator area. Run the motor for approximately 15 seconds. Disconnect the motor and spray it again, making sure the run-off is clear and clean. If the run-off is still dirty, repeat the spraying action until clean. After completing the cleaning, apply a small amount of lightweight oil to each bushing for lubrication. Be careful not to apply too much oil, for this will pick up dirt and contaminate the commutator and brushes.

RADIO MAINTENANCE. A radio problem is not always caused by the radio system. Often it is the result of a combination of several factors which can include: motor noise, poor electrical connections, poor wiring layout, reversed or defective receiver crystals, weak transmitter batteries, and so on. If your radio problems persist, one of the following tips may help:

- 1** Make sure the motor brushes are free in their brush holders.
- 2** Try a different motor.
- 3** Try a different radio frequency.
- 4** Try mounting the receiver on its side with the crystal up to get it away from the chassis. Also move it away from the side of the chassis.
- 5** Try moving the receiver to the rear shock tower and mount the antenna on the rear bulkhead or shock strut.
- 6** Bundle the radio wires well away from the servo and battery wires. Either can generate a signal into the antenna wire.
- 7** The new high frequency speed controls can generate a signal which can cause interference with the receiver. Try to keep them two inches apart if possible.

Keep in mind that you can also run into outside interference. 75 MHz radio band will tend to be more susceptible to this problem than the 27 MHz band.

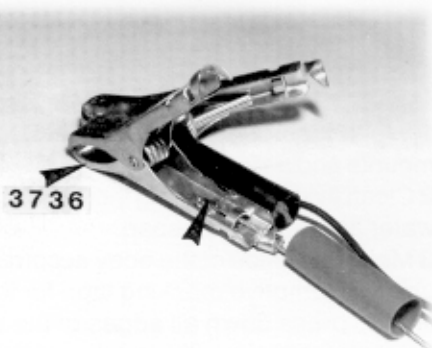

BUSHING MAINTENANCE. The #9011 Sport kit uses bronze bushings in place of the ball bearings used in the #9000 Racer kit. To get the maximum life from the bushings you should only clean them by wiping them off with a rag. Do not use any liquid cleaners on the bushings. The cleaners will remove the oil from the bushings and reduce their life.

DIFFERENTIAL MAINTENANCE. You should rebuild the differential when the action gets somewhat "gritty" feeling. Usually cleaning the diff and applying new lube per the instructions will bring it back to new condition. The standard 3/32" tungsten carbide diff balls should rarely need changing. Normally, as the parts seat, the diff will get smoother. If, after carefully cleaning and re-lubing the diff parts, the diff still feels gritty, the thrust balls, thrust washers, and drive rings should be checked and possibly replaced. The parts will normally wear in the following order: #6574 5/64" diff thrust balls, #6573 diff thrust washers, and #7666 2.60:1 diff drive rings. Refer to the diff section to correctly assemble the diff.

CLEANING YOUR BUGGY. You can clean your buggy and electronics (radio and speed control) with an electronics parts cleaner that is designated safe for plastics. They are convenient and work very well, but can be expensive. If you remove your electronics you can also clean the buggy and motor with motor cleaning sprays. Like the electronics cleaners, this works very well, but can cost a lot. To keep your maintenance costs down, you can clean the buggy (not the motor or electronics) with normal household cleaners like 409, Fantastic, Simple Green or Associated's #711 Reedy Car Wash. These cleaners have more water in them, so to prevent rust on the metal parts you must completely dry all of these parts, or else spray them with WD40. **WARNING!** Most of these cleaners have chemicals in them that will affect the Lexan body. The best way to clean your Lexan body is with warm water and a mild dish soap.

TUNING & SETUP TIPS

Your B2 is one of the most tunable off road cars on the market. This section will try to explain the parts and adjustments you can use to tune your car for different track conditions.

DIFFERENTIAL ADJUSTMENT. Once the differential has been correctly adjusted, there should be no need to change it until rebuilding time.

1 Tighten the diff screw down until the T-nut reaches the bottom of the diff hub slot or you feel the spring fully compressed. Do not over-tighten. When you feel the spring fully compressed, loosen the diff bolt 1/8 of a turn. No more, no less.

2 On a new or just rebuilt differential, apply a small amount of throttle while holding one of the rear wheels stationary. Do this for about 10 seconds. This will correctly seat all of the differential parts.

3 Now recheck the diff adjustment by again following step 1 above.

TORQUE CLUTCH ADJUSTMENT. It is possible to over-tighten the torque clutch. If you do, you may damage the diff gears when landing off a jump. On a new or just rebuilt torque clutch, run the setting a little on the loose side for about one minute before readjustment to race settings. With a fully charged battery, your torque clutch should only slip 2-3 feet before fully engaging. On a high traction surface you can adjust the torque clutch a little tighter than you would on a low traction surface.

Remember the purpose of the clutch is to gain traction, not to break the tires loose.

CASTER describes the angle of the kingpin in relation to the vertical plane, when looked at from the side of the car. As an example, 0° of caster means the kingpin is straight up and down. Positive caster means the kingpin leans rearward at the top.



Associated makes block carriers for the RC10B2 with 20°, 25°, and 30° of caster. Your kit comes with block carriers with 30° of caster, which is recommended for off road racing.

30° of caster will give your car increased steering entering corners but will have less steering exiting corners. It will also be more stable when accelerating through fast bumpy track conditions. Less caster (changing to block carriers with 25° or 20° of caster) will decrease the amount of steering entering corners but will increase steering in the middle and exiting corners. It will also tend to be less stable in fast, bumpy conditions.

CAMBER describes the angle at which the tire and wheel rides relative to the ground when looked at from the front or back. Negative camber means that the tire leans inward at the top. Positive camber means just the opposite. Positive camber should never be used.

Increasing negative camber (more than 3°) will decrease traction but improve stability in bumps. Less negative camber (0° to 1°) will have the maximum amount of traction but will be

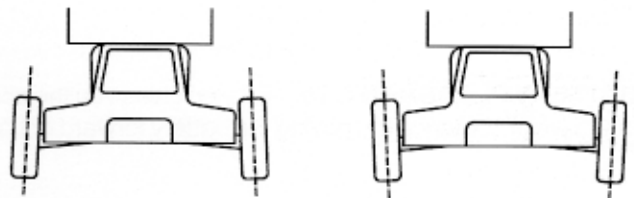

USE THIS (negative camber)

DON'T USE (positive)

less stable in bumpy conditions. We suggest using between 1° and 3° of negative camber at all times.

FRONT TOE-IN AND TOE-OUT. Adding toe-in to the front tires helps stabilize your buggy under acceleration, but at the same time it will decrease the amount of steering when entering a corner.

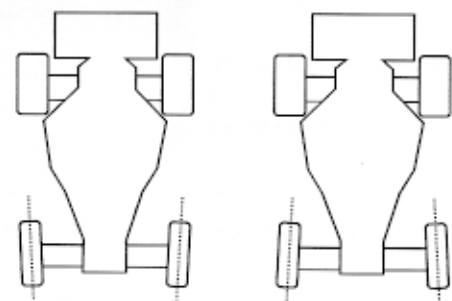

FRONT TOE-IN

FRONT TOE-OUT

Toe-out will add steering entering a corner but will cause instability when accelerating through bumps or down a slippery straightway.

REAR TOE-IN. Rear toe-in affects front and rear traction. Decreasing rear toe-in decreases rear traction and adds steering. Increasing rear toe-in will do just the opposite.

Your B2 comes with 3 • of rear toe-in per arm mount, for a total of 6 •. The kit also comes with 0 • rear hub carriers. This setup works best for almost all track conditions. It is rarely changed. However Associated offers optional 2 • arm mounts and 1.5 • hub carriers for different track conditions.

WHEELBASE ADJUSTMENT. The RC10B2 wheelbase can be changed easily to allow further fine tuning of your car for different track conditions. This can be accomplished by moving the two #6466 1/16" plastic spacers on the rear outer hinge pin (next to the rear hub carrier). Refer to the drawing below to see where the standard position is for your kit.

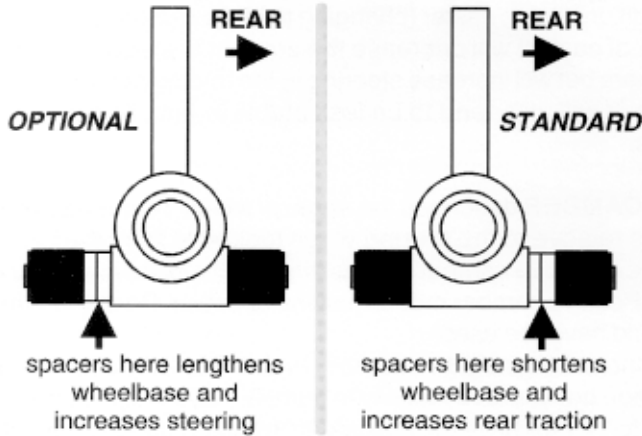

BATTERY PLACEMENT. Your B2 also gives you the ability to change weight balance by moving the battery forward or back.

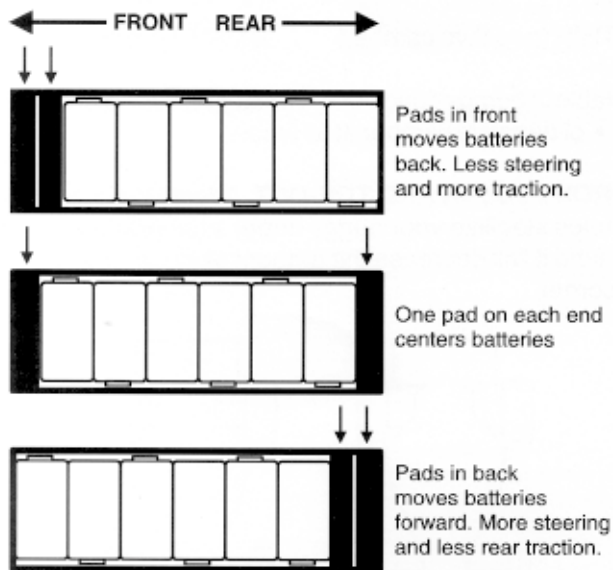

You can accomplish these changes by moving the #9238 foam battery spacers to the front or rear of the battery pack.

RIDE HEIGHT. Now we check the ride height of your B2 to make sure the settings are correct. Before we make this adjustment we should have everything in the car just as if you were going out to run it, but leave off the body.

For the front, push down on the front suspension and then let go. When the suspension stops, the front arms should be level with the bottom of the nose plate. If not, you can make adjustments by raising or lowering the front shock spring clamps.



FRONT RIDE HEIGHT

Now push down on the back suspension and let go. The axle dogbones should be level. Look at the rear end photo to compare. You adjust the rear shock spring clamps to make changes to the rear ride height.



REAR RIDE HEIGHT

Remember that if you move the battery forward or back this will change the weight balance of the car, so you will have to recheck the ride height.

STEERING ACKERMAN. Your RC10B2 gives you the choice of two steering Ackerman settings.

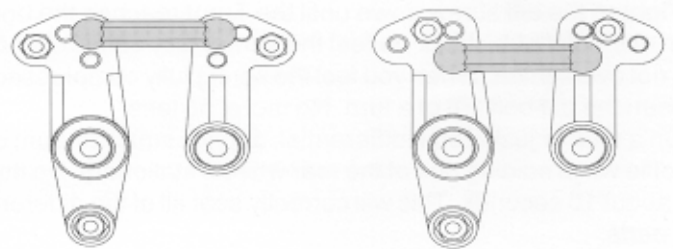

STANDARD SETUP

OPTIONAL SETUP

Standard setup. This is what we recommend for most drivers. This setting gives the car less aggressive steering and a more forgiving driving feel.

Optional setup. Less Ackerman. Gives the car more aggressive steering but the car will be less forgiving to drive. This setup is rarely used.

MOTOR GEARING. To get the most from your motor proper gearing is important. The gear ratios listed in the chart below are recommended starting gear ratios. Ratios can vary from track to track but you should not change the pinion size more than one tooth from the recommended ratio.

CAUTION! Increasing the pinion size by more than one tooth can damage your motor from excess heat.

MOTOR	PINION	SPUR	FINAL DRIVE RATIO
24 deg ROAR stock motor	25	81	7.78:1
DS Spec motor (kit motor)	25	81	7.78:1
36 deg stock motor	21	81	9.26:1
14 turn modified motor	22	84	9.16:1
13 turn modified motor	21	84	9.60:1
12 turn modified motor	20	84	10.08:1
11 turn modified motor	19	84	10.61:1
10 turn modified motor	18	84	11.20:1

FINAL DRIVE RATIO. The "final drive ratio" is a term used to show how many revolutions the motor turns in relation to one wheel revolution. This is a popular way to figure gear ratios as the internal ratios vary with different types of transmissions. The following is the formula for calculating final drive ratios:

$$(\text{spur gear} \div \text{pinion gear}) \times \text{B2 transmission ratio} = \text{final drive ratio}$$

$$(\text{81} \div \text{25}) \times \text{2.4} = \text{7.78}$$

OPTIONAL RACING PARTS

Associated is also offering a standard and short chassis plus special carbon fiber composite parts for the serious racer. Here is a list of the available accessory parts:

- 7700 Ball bearing kit
- 9199 Chassis, standard (carbon fiber composite)
- 9201 Chassis, short (composite)
- 9202 Chassis, short (carbon fiber composite)
- 9106 Front suspension arms (carbon fiber composite)
- 9131 Front top plate, molded (carbon fiber composite)
- 9141 Front shock strut, laminated (graphite)
- 9229 Battery strap, standard (carbon fiber composite)
- 9321 Battery strap, short (composite)
- 9232 Battery strap, short (carbon fiber composite)
- 9256 Rear suspension arms, (carbon fiber composite)
- 9266 Rear suspension mounts, 2 deg. Toe-in per side
- 9271 Rear shock strut (carbon fiber composite)
- 9381 Transmission brace (carbon fiber composite)
- 9455 .078" Wing wire, prebent
- 9248 Gear cover, fits Losi Hydra Drive and Schumacher Viscous Drive
- 9162 Ball bearings for right side steering bellcrank
- 6416 Unobtainium shock shaft, 1.32" stroke
- 6417 Unobtainium shock shaft, 1.02" stroke
- 6418 Unobtainium shock shaft .0.71" stroke
- 6193 Aluminum wing mounts

B2 SETUP SHEET

The next page shows Team Associated's setup sheet for the B2. Copy this form and keep a record of the settings you used for a particular track. This record of your settings will make it easier to set up your car the next time you race at that track, as well as compare differences between tuning adjustments. This is a feature that our Team drivers take full advantage of.

SAVE THIS BOOKLET!!

More than an instruction manual, its also a handy pictorial supplement to Team Associated's RC10B2 catalog.

Refer to this manual for part numbers and description when ordering parts or explaining problems for customer service calls.

RC10^{B2} SETUP SHEET FOR THE 9000, 9011 KITS



driver _____
 track _____
 date _____

FRONT SUSPENSION

FRONT BLOCK CARRIER (caster setting)

15° 20° 25° 30°

FRONT RIDE HEIGHT: _____

STEERING BLOCK _____

CAMBER _____

NOTES _____

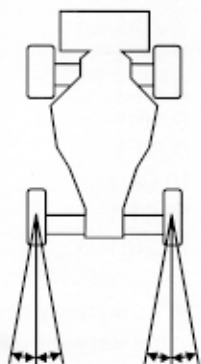
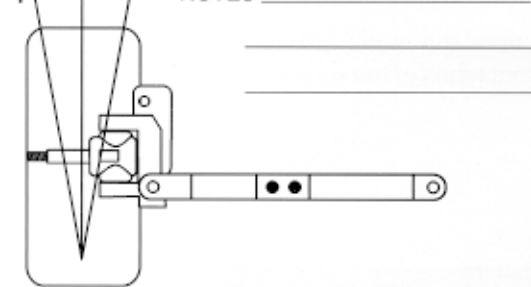

TOE-IN _____°
 TOE-OUT _____°

FRONT SHOCKS

STD OTHER OIL _____ PISTON _____

BODY _____ SHAFT _____ SPRING _____

LIMITERS, inside _____ outside _____

NOTES _____

INSIDE
 OUTSIDE
 Other (draw)

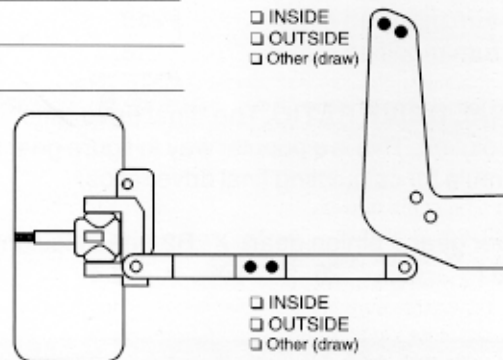

INSIDE
 OUTSIDE
 Other (draw)

REAR SUSPENSION

SUSPENSION MOUNTS: 2° 3°

WHEEL HUB: 0° 1.5° 3°

REAR RIDE HEIGHT: _____

ANTI-SQUAT STD OTHER _____

CAMBER _____

NOTES _____

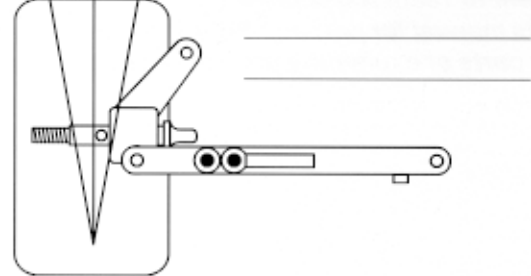

WHEEL HUB PLACEMENT **REAR**

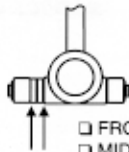
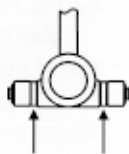
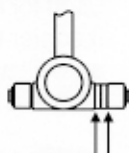

FRONT
 MIDDLE
 REAR

REAR SHOCKS

STD OTHER OIL _____

PISTON _____ SPRING _____

LIMITERS, inside _____ outside _____

NOTES _____

INSIDE
 MIDDLE
 OUTSIDE
 Other (draw)

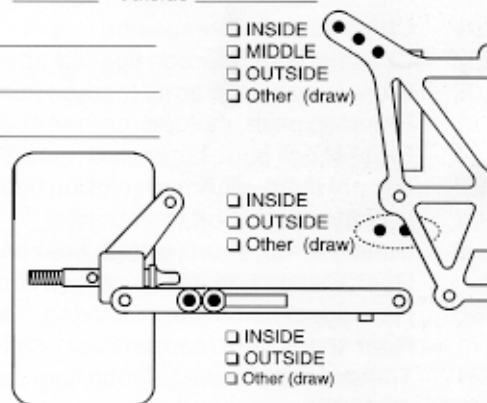

INSIDE
 OUTSIDE
 Other (draw)

INSIDE
 OUTSIDE
 Other (draw)

OTHER

TIRES & WHEELS

FRONT TIRES _____ FOAM _____

REAR TIRES _____ FOAM _____

FRONT WHEELS 1 PIECE 3 PIECE OTHER

CHASSIS STD SHORT GRAPHITE

MOTOR, TRANSMISSION & ELECTRICAL

MOTOR _____ PINION _____ SPUR GEAR _____

DRIVESHAFTS _____

SLIPPER STD HYDRA VISCO OIL _____

BATTERY TYPE _____ PLACEMENT FRONT MIDDLE REAR

RADIO _____ SPD. CONT. _____ SERVO _____

COMMENTS/EXCUSES _____

REEDY Modifieds

Reedy Modifieds is a leader in superior motors and batteries for R/C cars and trucks. To date, Reedy has powered 17 World Champions—more than all the other motor manufacturers combined.

Serious racers have catapulted his successful Sonic and Ultra Sonic modified motor series into must-have status for race-winning results. His stock and modified motors come in numerous winds to tune your vehicle to any track and temperament.

Mike Reedy's batteries have been favored by racers for years; they come in 6 and 7-cell matched packs.



Sonic2

Reedy Modifieds has done it again with the release of the Z Series motor. This is an entirely new motor designed from the ground up.

We started with new tooling. This was changed to improve the placement and alignment of the magnets. The can is also a thicker 1.4mm material.

To go with the new can, Reedy used a new magnet material. This material maintains its strength when hot and the magnetic field is stronger at the magnet edge. A major improvement over the old magnets.

No part of this motor was unchanged. The new end bell uses lightweight and temperature-stable, glass-filled nylon. The end bell also features a new self-centering alignment system. This assures optimum armature to magnet symmetry. Also built in is a new brush vibration dampening system. At high RPM's,



TriSonic

the brushes begin to bounce and chatter. This robs horsepower. Mike Reedy developed this system to regain this power.

The final update is the armature. The new Sonic 2, large commutator, high torque motor uses an armature with laminations configured to maximize engine torque. At the opposite end, the new TriSonic motor has armature laminations that improve RPM instead of torque. Finally, for the new

Fire Hawk stock motor, Reedy used a combination of the new RPM laminations and armature configuration to improve both RPM and torque.

Try one of these new motors and see why Reedy is the dominant force in all classes.



Fire Hawk

LRP DIGITAL

Totally new digital technology! The LRP Digital Speed Control surpasses every other type of speed control available. It uses a digital miniature computer with simple, push-button setup. This results in significant advantages. It runs so cool that it does not require heat sinks. It does not waste battery power heating the heat sinks. This in turn results in longer run times. You may then gear higher and go faster, and still make the time. The all new Digital Computerized Technology allows the driver to adjust the amount of initial braking to suit both his driving style and the amount of traction on the track.

LRP ICS Digital DIGITAL

LRP's ICS was the first speed control to run so cool, it saved energy and didn't require heat sinks. This also resulted in longer run time and more top speed. There is also a special function which allows faster starts. LRP's Advanced Digital Technology, using finer pulse rates, actually gives the cars more traction in the corners. A simple push-button setup makes it easy to use and understand. The current limiter function is important on slippery tracks and for 1:12 on road racing. #LRP 8066, \$225.00



#LRP8066
LRP ICS

LRP F1 SERIES

FORWARD + REVERSE

Speed controls with forward and reverse are not new. But the old style forward and reverse speed controls require that you slam it into reverse while you're still going forward in order to slow the car down, and then finally go into reverse. It would be impossible to think about racing effectively with this handicap.

LRP's new F1 series of speed controls allow you to have full proportional throttle and full proportional EMK brake control, just like on the LRP ICS model. In addition, when the car comes to a complete stop, you have full proportional reverse for 5 seconds. Digital microchip controlled, high frequency, single button setup, bec integrated and fully protected, and temperature controlled protection. Another new, higher level of LRP speed controls.



#LRP8317
F1 DIGITAL



#LRP8322
F1-POWER DIGITAL



#LRP8335
F1 BULLET DIGITAL

FEATURE COMPARISONS

	Input Voltage	On-Resistance	PWM Frequency	Current Limiter	Price
LRP8317	4.8 - 8.4V max	0.017 Ohm	2100Hz		99.50
LRP8322	4.8 - 8.4V max	0.009 Ohm	2300Hz	●	132.00
LRP8335	4.8 - 8.4V max	0.0045 Ohm	2500Hz	●	175.00

PRICES SUBJECT TO CHANGE WITHOUT NOTICE.



**#9000
RC10B2 RACER**



**#9011
RC10B2 SPORT**