

Front Suspension:

Ride Height:	16mm
Camber:	-1.5
Toe:	+1
Anti-Roll Bar:	1.8
Wheelbase Shim:	front
Wheel Hex:	6mm
Caster Block:	7° 10° 13° <input checked="" type="checkbox"/>
Notes:	

Axle Height:

+3

+2

+1

0

Bump Steer Spacing: 2mm

Ball Stud Spacing: 0mm

Steering Plate: kit

Ball Stud Spacing: 0mm

Arm Mount A:

LRC HRC 1° 0.5°



Arm Mount B:

LRC HRC 1° 0.5°

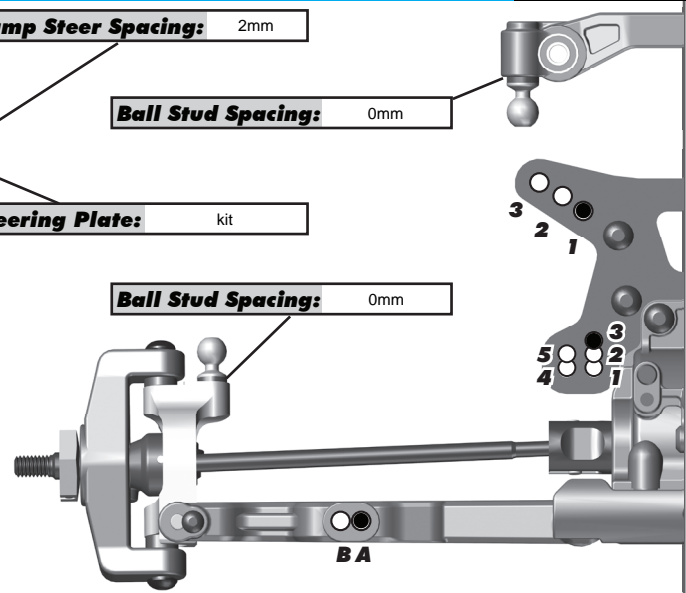
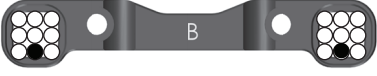

RESET

Rear Suspension:

Ride Height:	16mm
Camber:	-2
Anti-Roll Bar:	1.8
Wheelbase Shim:	front
Wheel Hex:	5mm
Hub Spacing:	Forward Middle <input checked="" type="checkbox"/> Back
Gearbox Shim:	Yes No <input checked="" type="checkbox"/>
Chassis Brace:	Short Long <input checked="" type="checkbox"/>
Notes:	

Arm Mount C:

LRC HRC 1° 0.5°



Arm Mount D:

LRC HRC 1° 0.5°



Rear Hub Link Setting:

Up

E C A

D B

Down

B

E C A

Hub Insert:

+3 +2 +1 0

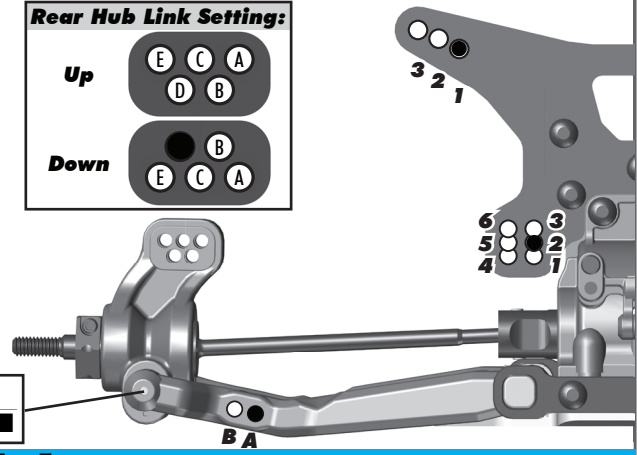

Electronics:

Radio:	M12	Servo:	Reedy
EPA: Throttle:	100 %	Brake:	83 %
ESC:	Reedy		
ESC Settings:			
Motor:	Reedy		
Wind:	6.0	Timing:	20
Pinion:	20	Spur:	81
Battery:			
Battery Position:			

Differential:

Front Fluid:	10K
Gears:	Plastic Metal <input checked="" type="checkbox"/>
Center Fluid:	
Gears:	Plastic Metal
Rear Fluid:	7k
Gears:	Plastic Metal <input checked="" type="checkbox"/>
Slipper Clutch:	
Type:	SLIPPER a little loose
# of Pads:	

Shocks:

	Front	Rear
Piston:	2*1.6	2*1.7
Fluid:	35	27.5
Spring:	Purple	Blue
Limiters:		
Stroke:	22.5	29.5
Eyelet Length:	long	short
Cup Offset:	+5	0
Notes:		

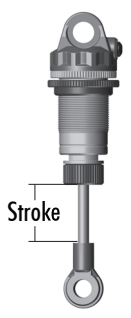

Track Info:

Size:	Small Medium <input checked="" type="checkbox"/> Large Extra Large
Surface:	Dirt Carpet Astroturf <input checked="" type="checkbox"/> Multi Surface
Traction:	Low Medium High Very High
Moisture:	Dry <input checked="" type="checkbox"/> Damp Wet
Condition:	Indoor Outdoor <input checked="" type="checkbox"/> Dusty Hard Packed Bumpy Grooved Smooth Loamy
Temperature:	Ambient: _____ Track: _____
Notes:	

Tires:

Front Tires:	MINI PIN
Front Compound:	Yellow
Front Insert:	Medium
Rear Tires:	MINI PIN
Rear Compound:	Yellow
Rear Insert:	Medium
Wheel (F/R):	
Notes:	

Body, Wing, Weight:

Body:	JC LIGHT
Wing:	JC AREO
Wing Angle:	0° 3° 6° <input checked="" type="checkbox"/>
Chassis Weights:	None 15g 30g <input checked="" type="checkbox"/> Other
Other Weights:	
Total Vehicle Weight:	

Vehicle Comments:

Notes: