

## Front Suspension:

<b>Ride Height:</b>	15
<b>Camber:</b>	-2
<b>Toe:</b>	+1
<b>Anti-Roll Bar:</b>	1.8
<b>Wheelbase Shim:</b>	front
<b>Wheel Hex:</b>	6.5
<b>Caster Block:</b>	7° 10° 13° <input type="checkbox"/>
<b>Notes:</b>	

**Axle Height:**

+3

+2

+1

0

**Bump Steer Spacing:** 2mm

**Ball Stud Spacing:** 0mm

**Steering Plate:** KIT

**Ball Stud Spacing:** 0mm

**Arm Mount A:**

LRC  HRC  1°  0.5°



**Arm Mount B:**

LRC  HRC  1°  0.5°

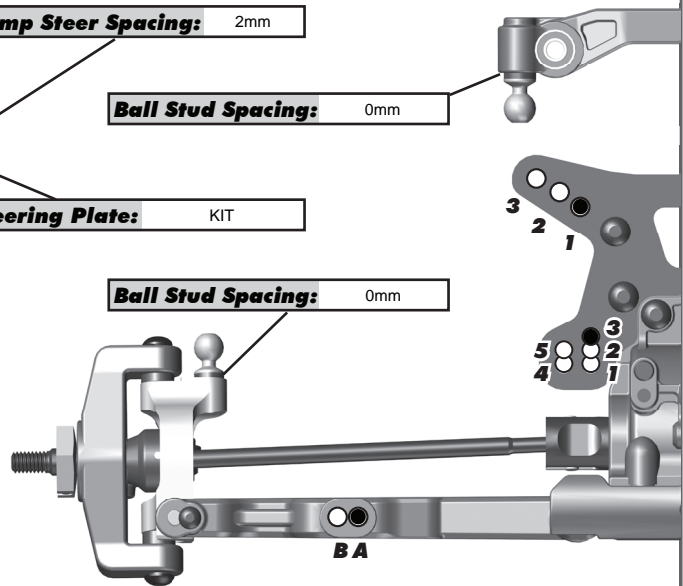

## Rear Suspension:

<b>Ride Height:</b>	15
<b>Camber:</b>	-2
<b>Anti-Roll Bar:</b>	1.8
<b>Wheelbase Shim:</b>	front
<b>Wheel Hex:</b>	6mm
<b>Hub Spacing:</b>	Forward Middle Back <input type="checkbox"/>
<b>Gearbox Shim:</b>	Yes No <input checked="" type="checkbox"/>
<b>Chassis Brace:</b>	Short Long
<b>Notes:</b>	Prototype Chassis Brace text me for more info, on facebook or on jesperrc.jr@gmail.com
	Long Wheel base

**Arm Mount C:**

LRC  HRC  1°  0.5°



**Arm Mount D:**

LRC  HRC  1°  0.5°



### Rear Hub Link Setting:

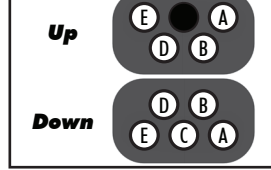

**Hub Insert:**

+3  +2  +1  0

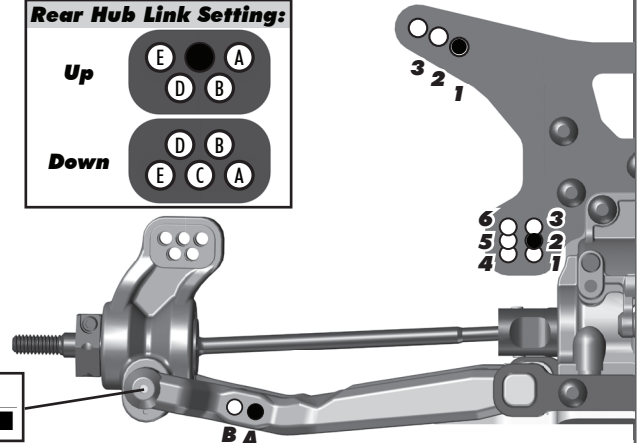

## Electronics:

<b>Radio:</b>	M12	<b>Servo:</b>	Reedy
<b>EPA: Throttle:</b>	100 %	<b>Brake:</b>	83 %
<b>ESC:</b>	Reedy		
<b>ESC Settings:</b>			
<b>Motor:</b>	Reedy		
<b>Wind:</b>	6.5	<b>Timing:</b>	20
<b>Pinion:</b>	21	<b>Spur:</b>	81
<b>Battery:</b>	Reedy		
<b>Battery Position:</b>	forward		

## Differential:

<b>Front Fluid:</b>	10k
<b>Gears:</b>	Plastic Metal <input checked="" type="checkbox"/>
<b>Center Fluid:</b>	300K
<b>Gears:</b>	Plastic Metal <input checked="" type="checkbox"/>
<b>Rear Fluid:</b>	7k
<b>Gears:</b>	Plastic Metal <input checked="" type="checkbox"/>
<b>Slipper Clutch:</b>	
<b>Type:</b>	
<b># of Pads:</b>	

## Shocks:

	Front	Rear
<b>Piston:</b>	2*1.6	2*1.7
<b>Fluid:</b>	35	27.5
<b>Spring:</b>	Purple	Green
<b>Limiters:</b>		
<b>Stroke:</b>	24	29.5
<b>Eyelet Length:</b>	long	short
<b>Cup Offset:</b>	+5	+0
<b>Notes:</b>	Yokomo Silver springs	



## Track Info:

<b>Size:</b>	Small Medium <input checked="" type="checkbox"/> Large Extra Large
<b>Surface:</b>	Dirt Carpet <input checked="" type="checkbox"/> Astroturf Multi Surface
<b>Traction:</b>	Low Medium <input checked="" type="checkbox"/> High Very High
<b>Moisture:</b>	Dry <input checked="" type="checkbox"/> Damp Wet <input checked="" type="checkbox"/>
<b>Condition:</b>	Indoor Outdoor <input checked="" type="checkbox"/> Dusty Hard Packed Bumpy Grooved Smooth Loamy
<b>Temperature:</b>	Ambient: Track:
<b>Notes:</b>	

## Tires:

<b>Front Tires:</b>	Mini pin / Blasstic
<b>Front Compound:</b>	
<b>Front Insert:</b>	Medium
<b>Rear Tires:</b>	Mini Pin/ Blasstic
<b>Rear Compound:</b>	
<b>Rear Insert:</b>	Medium
<b>Wheel (F/R):</b>	
<b>Notes:</b>	

## Body, Wing, Weight:

<b>Body:</b>	JC F2 Light
<b>Wing:</b>	JC Aero
<b>Wing Angle:</b>	0° 3° 6° <input checked="" type="checkbox"/>
<b>Chassis Weights:</b>	None 15g <input checked="" type="checkbox"/> 30g Other
<b>Other Weights:</b>	
<b>Total Vehicle Weight:</b>	

## Vehicle Comments:

**Notes:** It started to Rain after Q1