

Front Suspension

Ride Height: \_\_\_\_\_  
 Camber: \_\_\_\_\_  
 Toe: \_\_\_\_\_  
 Anti-Roll Bar: \_\_\_\_\_  
 Wheelbase Shim: \_\_\_\_\_  
 Wheel Hex: \_\_\_\_\_  
 Caster Block: \_\_\_\_\_  
 Notes: \_\_\_\_\_

**Axle Height:**

+3   
 +2   
 +1   
 0

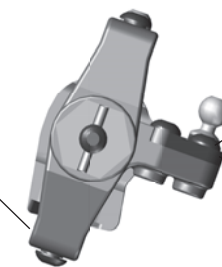

**Bump Steer Spacing:** \_\_\_\_\_

**Ball Stud Spacing:** \_\_\_\_\_

**Steering Plate:** \_\_\_\_\_

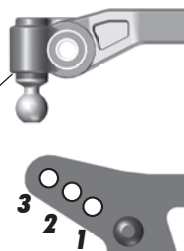

**Arm Mount A:**

LRC  HRC  1°  0.5°

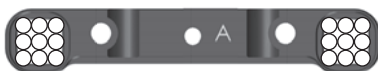

**Arm Mount B:**

LRC  HRC  1°  0.5°

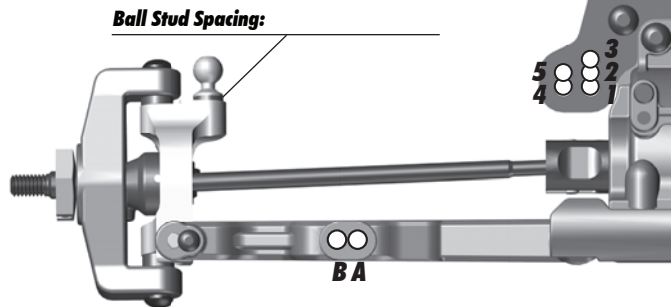

Rear Suspension

Ride Height: \_\_\_\_\_  
 Camber: \_\_\_\_\_  
 Anti-Roll Bar: \_\_\_\_\_  
 Wheel Hex: \_\_\_\_\_  
 Hub Spacing: Forward  Middle  Back   
 Gearbox Shim: Yes  No   
 Chassis Brace: Short  Long   
 Notes: \_\_\_\_\_

**Arm Mount C:**

LRC  HRC  1°  0.5°



**Arm Mount D:**

LRC  HRC  1°  0.5°



**Rear Hub Link Setting:**



**Ball Stud Spacing:**

**Spacing:** \_\_\_\_\_

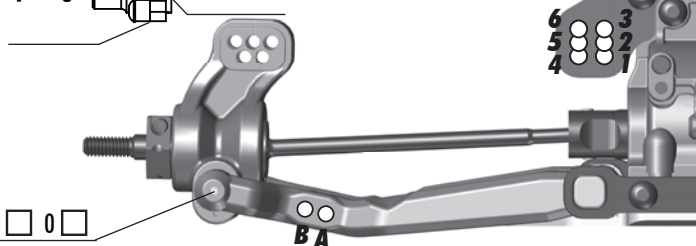

**Hub Insert:**

+3  +2  +1  0

Track Info, Tires & Aero Electronics, Drivetrain & Shocks

**Radio:** \_\_\_\_\_ **Servo:** \_\_\_\_\_  
 EPA: Throttle: \_\_\_\_\_ % Brake: \_\_\_\_\_ %  
**ESC:** \_\_\_\_\_  
**ESC Settings:** \_\_\_\_\_  
**Motor:** \_\_\_\_\_ **Timing:** \_\_\_\_\_  
**Pinion:** \_\_\_\_\_ **Spur:** \_\_\_\_\_  
**Battery:** \_\_\_\_\_  
**Battery Position:** \_\_\_\_\_

**Front Fluid:** \_\_\_\_\_  
**Gears:** Plastic  Metal   
**Center Fluid:** \_\_\_\_\_  
**Gears:** Plastic  Metal   
**Rear Fluid:** \_\_\_\_\_  
**Gears:** Plastic  Metal   
**Slipper Clutch:** \_\_\_\_\_  
**# of Pads:** \_\_\_\_\_

	Front	Rear
	<b>Shocks:</b>	
<b>Piston:</b>		
<b>Fluid:</b>		
<b>Spring:</b>		
<b>Limiters:</b>		
<b>Stroke:</b>		
<b>Eyelet Length:</b>		
<b>Cup Offset:</b>		
<b>Notes:</b>		

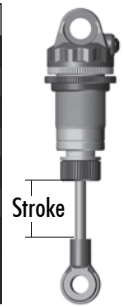

**Size:** Small  Medium  Large  Extra Large   
**Surface:** Dirt  Carpet  Astroturf  Multi Surface   
**Traction:** Low  Medium  High  Very High   
**Moisture:** Dry  Damp  Wet   
**Condition:** Indoor  Outdoor  Dusty  Hard Packed   
 Bumpy  Grooved  Smooth  Loamy   
**Temperature:** Ambient: \_\_\_\_\_ Humidity: \_\_\_\_\_  
**Notes:** \_\_\_\_\_

**Front Tires:** \_\_\_\_\_  
**Front Compound:** \_\_\_\_\_  
**Front Insert:** \_\_\_\_\_  
**Rear Tires:** \_\_\_\_\_  
**Rear Compound:** \_\_\_\_\_  
**Rear Insert:** \_\_\_\_\_  
**Wheel (F/R):** \_\_\_\_\_  
**Notes:** \_\_\_\_\_

**Body:** \_\_\_\_\_  
**Wing:** \_\_\_\_\_  
**Wing Angle:** 0°  3°  6°   
**Chassis Weights:** \_\_\_\_\_  
 None  15g  30g  Other   
**Other Weights:** \_\_\_\_\_  
**Total Vehicle Weight:** \_\_\_\_\_

Comments

\_\_\_\_\_